

# AIRA ATH

## Vacuum Assisted Linear, Double Linear, U-Tube, and Multi-Burner Gas Fired Heating Systems

### Installation, Operation & Service Manual

#### FOR YOUR SAFETY

If you smell gas:

1. Open windows.
2. DO NOT try to light any appliance.
3. DO NOT use electrical switches.
4. DO NOT use any telephone in your building.
5. Extinguish any open flame.
6. Leave the building.
7. Immediately call your local gas supplier after leaving the building. Follow the gas supplier's instructions.
8. If you cannot reach your gas supplier, call the Fire Department.

#### WARNING



Fire Hazard

Keep all flammable objects, liquids and vapors the minimum required clearances to combustibles away from heater.

Some objects will catch fire or explode when placed close to heater.

Failure to follow these instructions can result in death, injury or property damage.

ATH15UT	ATH15ST	ATH30DL
ATH20UT	ATH20ST	ATH40DL
ATH25UT	ATH25ST	ATH50DL
ATH30UT	ATH30ST	ATH60DL
ATH35UT	ATH35ST	ATH70DL
ATH40UT	ATH40ST	
ATH45UT	ATH45ST	
ATH50UT	ATH50ST	

#### WARNING

Improper installation, adjustment, alteration, service or maintenance can result in death, injury or property damage. Read the installation, operation and service manual thoroughly before installing or servicing this equipment.

Installation must be done by a registered installer/contractor qualified in the installation and service of gas-fired heating equipment or your gas supplier.

#### Installer

Please take the time to read and understand these instructions prior to any installation. Installer must give a copy of this manual to the owner.

#### Owner

Keep this manual in a safe place in order to provide your service technician with necessary information.

#### Aira Pty Ltd

144 Colchester Road  
Kilsyth, VIC 3137  
Telephone: +61 3 9839 8000  
Fax: +61 3 9761 4732  
Email: sales@aira.com.au

[www.aira.com.au](http://www.aira.com.au)



## TABLE OF CONTENTS

<b>SECTION 1: Heater Safety.....</b>	<b>2</b>	System Checks.....	58
1.1 Manpower Requirements.....	2	14.5 User Instructions.....	58
1.2 Safety Labels and Their Placement.....	2	<b>SECTION 15: Servicing Instructions.....</b>	<b>60</b>
<b>SECTION 2: Installer Responsibility .....</b>	<b>4</b>	15.1 Annual Procedure .....	60
2.1 Low Level User Instructions .....	4	15.2 Component Removal.....	60
2.2 Corrosive Chemicals .....	4	15.3 Maintenance Checklist .....	61
2.3 National Standards and Applicable Codes.....	4	<b>SECTION 16: Troubleshooting .....</b>	<b>63</b>
<b>SECTION 3: Clearances to Combustibles .....</b>	<b>5</b>	16.1 Troubleshooting Flow Chart	
3.1 Required Clearances to Combustibles.....	5	(Linear, Double Linear and U-Tube) .....	64
3.2 Clearance Data - Linear and Double Linear.....	6	16.2 Troubleshooting Flow Chart (Multiburner).....	66
3.3 Clearance Data -U Tube.....	8	16.3 Manifold Gas Pressure Setting .....	68
<b>SECTION 4: Major Component Descriptions .....</b>	<b>10</b>	<b>SECTION 17: Replacement Parts .....</b>	<b>69</b>
<b>SECTION 5: General Suspension Details .....</b>	<b>11</b>	<b>SECTION 18: Specifications .....</b>	<b>71</b>
<b>SECTION 6: Linear &amp; Double Linear Heater</b>		18.1 Material Specifications.....	71
<b>Installation .....</b>	<b>13</b>	18.2 Heater Specifications.....	71
6.1 Linear Standard Parts List.....	13	18.3 Venting Specifications .....	71
6.2 Double Linear Standard Parts List .....	16	18.4 Suspension Specifications .....	71
<b>SECTION 7: U-Tube Heater Installation .....</b>	<b>25</b>	18.5 Controls Specifications .....	71
7.1 U-Tube Standard Parts List.....	25	18.6 Environment .....	71
<b>SECTION 8: Multiburner Configuration &amp;</b>		18.7 Linear Heater.....	72
<b>Installation .....</b>	<b>34</b>	18.8 Double Linear Heater .....	72
8.1 Initial Assembly .....	34	18.9 U-Tube Heater .....	72
<b>SECTION 9: Burner &amp; Fan Installation.....</b>	<b>36</b>	18.10 Burner Specifications.....	73
9.3 Linear & U-Tube Fan Installation .....	37		
<b>SECTION 10: Optional Heater Accessories.....</b>	<b>40</b>		
10.1 Reflector Side Extension Installation.....	41		
10.2 U-Tube Cover Installation .....	42		
10.3 Decorative Grille Installation.....	43		
10.4 Protective Grille Installation .....	44		
10.5 Sports Hall Guard Installation .....	45		
10.6 Undershield Installation .....	46		
10.7 Wall Mounting.....	47		
<b>SECTION 11: Venting.....</b>	<b>49</b>		
11.1 General Venting Requirements .....	49		
11.2 Ventilation Requirements .....	49		
11.3 Outside Combustion Air Supply .....	50		
11.4 Common Duct .....	51		
<b>SECTION 12: Gas Piping .....</b>	<b>52</b>		
<b>SECTION 13: Wiring.....</b>	<b>54</b>		
13.1 Typical External Wiring Diagram			
(Linear or U-Tube).....	54		
13.2 Typical External Wiring Diagram			
(Double Linear Option 1).....	54		
13.3 Typical External Wiring Diagram			
(Double Linear Option 2).....	55		
13.4 Typical External Wiring Diagram			
(Multiburner) .....	55		
13.5 Internal Wiring Diagram.....	56		
<b>SECTION 14: Operation.....</b>	<b>57</b>		
14.1 Heater Lockout Indication (Optional).....	57		
14.2 Testing.....	58		
14.3 Commissioning (Multiburner) .....	58		

---

## TABLE OF FIGURES

Figure 1: Side and Back Panel Label Placement .....	2
Figure 2: Top Panel Label Placement .....	3
Figure 18: Critical Hanger Placement .....	12
Figure 19: Linear General Assembly Overview.....	14
Figure 20: Linear Layout Overview .....	15
Figure 21: Double Linear General Assembly Overview	17
Figure 22: Double Linear Layout Overview .....	18
Figure 23: U-Tube Assembly Overview.....	26
Figure 24: U-Tube Layout Overview.....	27
Figure 25: Multiburner Damper Flange Installation .....	34
Figure 26: Typical Manifold Layout (Linear and U-Tube Configuration) .....	35
Figure 27: U-Tube (Horizontal) .....	47
Figure 28: U-Tube (Angle Mounted).....	48
Figure 29: Linear .....	48
Figure 30: Individual Flue Connection Detail .....	50
Figure 31: Flue Connection Dimensions .....	50
Figure 32: Fresh Air Intake Spigot.....	51
Figure 33: Air Supply with Flue Configurations .....	51
Figure 34: Gas Connection with Stainless Steel Flex Connector .....	53
Figure 35: Sequence of Operation Chart .....	57
Figure 36: Burner Cup Position.....	60
Figure 37: Linear and U-Tube Specifications .....	73

---

## Product Approval

ROBERTS GORDON® equipment has been tested and CE certified as complying with the essential requirements of the Gas Appliance Directive, the Low Voltage Directive, the Electromagnetic Compatibility Directive and the Machinery Directive for use on natural gas and LPG when installed, commissioned and maintained in accordance with these instructions.

These instructions refer to appliances designed to operate in the European Union.

Appliances designed for other countries (Non-European Union) are available on request.

This appliance must be installed in accordance with the local and national codes in force and used only in a sufficiently ventilated space, as specified in these instructions.

Before installation, check that the local gas distribution systems, nature of gas and pressure, and adjustment of the appliance are compatible.

**SECTION 1: HEATER SAFETY**



Your Safety is Important to Us!  
 This symbol is used throughout the manual to notify you of possible fire, electrical or burn hazards. Please pay special attention when reading and following the warnings in these sections.

Installation, service and annual inspection of heater must be done by a registered installer/contractor qualified in the installation and service of gas-fired heating equipment.

Read this manual carefully before installation, operation or service of this equipment.

This heater is designed for heating nonresidential indoor spaces. Do not install in residential spaces. These instructions, the layout drawing, local codes and ordinances, and applicable standards that apply to gas piping, electrical wiring, venting, etc., must be thoroughly understood before proceeding with the installation.

Protective gear is to be worn during installation, operation and service. Thin sheet metal parts, such as the reflector portion of the heater and the various venting components, have sharp edges. To prevent injury, the use of work gloves is recommended. The use of gloves will also prevent the transfer of body oils from the hands to the surface of the reflector.

Before installation, check that the local distribution conditions, nature of gas and pressure, and adjustment of the appliance are compatible.

The heater must be applied and operated under the general concepts of reasonable use and installed using best building practices.

This equipment is not intended for use by persons (including children) with reduced physical, sensory or mental capabilities, or lack of experience and knowledge, unless they have been given supervision or instruction concerning use of the appliance by a person responsible for their safety. Children should be supervised to ensure that they do not play with the appliance.

For additional copies of the Installation, Operation and Service Manual, please contact Aira.

**1.1 Manpower Requirements**

To prevent personal injury and damage to the heater, two persons will be required for installation.

**1.2 Safety Labels and Their Placement**

Product safety signs or labels should be replaced by the product user when they are no longer legible. Contact Aira for obtaining replacement signs or labels. *See Page 2, Figure 1 through Page 3, Figure 2.*

**Figure 1: Side and Back Panel Label Placement**

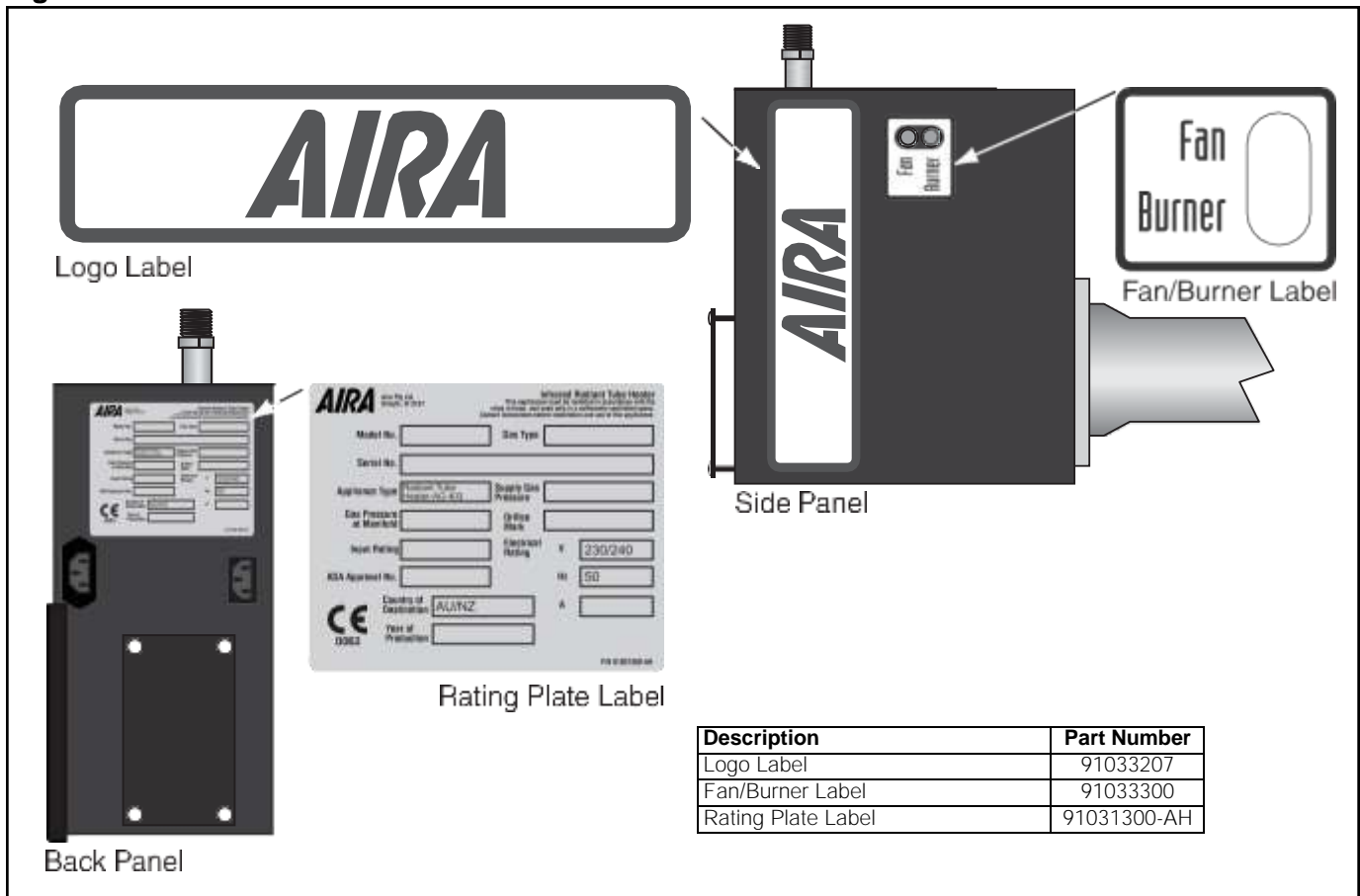



Figure 2: Top Panel Label Placement



Top Panel



Top Panel - Inside Door

**AWARNING**  
Fire Hazard  
Tighten end install gae hoe fittings to connect gae euppy ecorting to example below.  
Gae hoe can crack when twisted.  
Gae hose moves during normal operation.  
Use only 1000 mm long connector of 112" or 3/4" nominal ID.  
Failure to follow these instructions can result in death, injury or property damage.

**CORRECT POSITION**

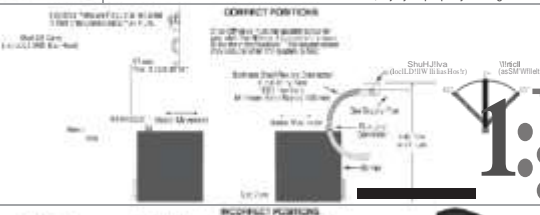

**INCORRECT POSITION**



Gas Connection Label

**INTERNAL WIRING DIAGRAM**

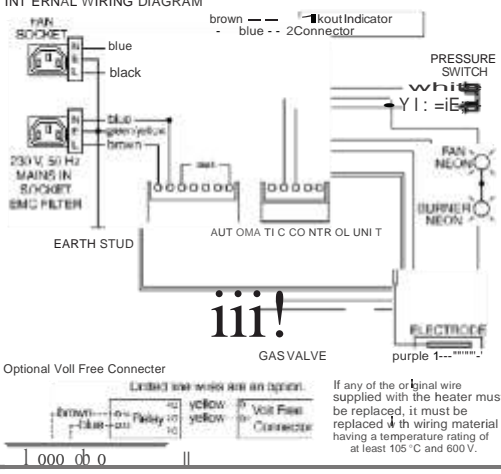

Legend:  
brown --- knockout Indicator  
blue --- 2 Connector

Optional Volt Free Connector

If any of the original wire supplied with the heater must be replaced, it must be replaced with wiring material having a temperature rating of at least 105°C and 600 V.

P/N 9103 1 40 1 Rev. M

Internal Wiring Label

Description	Part Number
Gas Connection Label	91018126
Internal Wiring Label	91031401

## SECTION 2: INSTALLER RESPONSIBILITY

- To install the heater, as well as the gas and electrical supplies, in accordance with applicable specifications and codes. Aira recommends the installer contact a local Building Inspector or Fire Marshal for guidance.
- To use the information given in a layout drawing and in the manual together with the cited codes and regulations to perform the installation.
- To install the heater in accordance with the clearances to combustibles.
- To furnish all needed materials not furnished as standard equipment.
- To plan location of supports.
- To provide access to burners for servicing on all sides, for burner removal.
- To provide the owner with a copy of this installation, operation and service manual.
- To never use heater as support for a ladder or other access equipment and never hang or suspend anything from heater.
- To ensure there is adequate air circulation around the heater and to supply air for combustion, ventilation and distribution in accordance with local codes.
- To safely and adequately install heater using materials with a minimal working load of 33 kg.
- To ensure the heater is placed in an approved application.

### 2.1 Low Level User Instructions

In all situations, clearances to combustibles must be maintained. Signs should be posted in storage areas to specify the maximum stacking height of items placed below heater to maintain required clearances to combustibles. Minimum clearances must be maintained from vehicles parked below the heater. Caution should be used when running the system near combustible materials such as wood, paper, rubber, etc. Consideration should be given to partitions, storage racks, hoists, building construction, etc.

A laminated wall tag is available for the heater as a permanent reminder of the safety instructions and the importance of the required clearances to combustibles. Please contact Aira or your Aira independent distributor to obtain the wall tag. Affix the tag by peeling off the backing of the adhesive strips on the rear surface and position the tag on a wall near the heater (e.g. thermostat).

A copy of the wall tag (P/N 91037912-AH) is illustrated on the back cover. This copy of the wall tag can be affixed on the wall near the heater. Know your model number and installed configuration. Model number and installed configuration are found on the burner and in the Installation, Operation and Service Manual. Write the largest clearance dimensions with permanent ink according to your model number and configuration in the open spaces on the tag.

### 2.2 Corrosive Chemicals

<p><b>Product Damage Hazard</b></p> <p><b>Do not use heater in area containing corrosive chemicals.</b></p> <p><b>Refer to appropriate Material Safety Data Sheets (MSDS).</b></p> <p><b>Failure to follow these instructions can result in product damage.</b></p>

Aira cannot be responsible for ensuring that all appropriate safety measures are undertaken prior to installation; this is entirely the responsibility of the installer. It is essential that the contractor, the sub-contractor, or the owner identifies the presence of combustible materials, corrosive chemicals or halogenated hydrocarbons\* anywhere in the premises.

**\* Halogenated Hydrocarbons** are a family of chemical compounds characterized by the presence of halogen elements (fluorine, chlorine, bromine, etc.). These compounds are frequently used in refrigerants, cleaning agents, solvents, etc. If these compounds enter the air supply of the burner, the lifespan of the heater components will be greatly reduced. An outside air supply must be provided to the burners whenever the presence of these compounds is suspected. Warranty will be invalid if the heater is exposed to halogenated hydrocarbons.

### 2.3 National Standards and Applicable Codes

All appliances must be installed in accordance with the latest revision of the applicable standards and national codes. This refers also to the electric, gas and venting installation. Note: Additional standards for installations in public garages, aircraft hangars, etc. may be applicable.

## SECTION 3: CLEARANCES TO COMBUSTIBLES

<p><b>Fire Hazard</b></p> <p><b>Keep all flammable objects, liquids and vapors the minimum required clearances to combustibles away from heater.</b></p> <p><b>Some objects will catch fire or explode when placed close to heater.</b></p> <p><b>Failure to follow these instructions can result in death, injury or property damage.</b></p>

- Consult local Building Inspector, Fire Insurance Carrier or other authorities for approval of proposed installation when there is a possibility of exposure to combustible airborne materials or vapours.
- Hang heater in accordance to the minimum suspension requirements on *Page 72, Section 18.7 through Section 18.9*.
- If the radiant tubes must pass through the building structure, be sure that adequate sleeving and fire stop is installed to prevent scorching and/or fire hazard.

### 3.1 Required Clearances to Combustibles

Clearances are the required distances that combustible objects must be away from the heater to prevent fire hazards. Caution should be used when running the system near combustibles. Combustibles are materials, which may catch on fire and include common items such as wood, paper, rubber, fabric, etc. **Maintain clearances to combustibles at all times for safety.**

Clearances for all heater models are located *on Page 6, Figure 3 through Page 9, Figure 17* in this manual. Check the clearances on each burner for the model heater being installed to make sure the product is suitable for your application and the clearances are maintained. Read and follow the safety guidelines below:

- Keep petrol or other combustible materials including flammable objects, liquids, dust or vapours away from this heater or any other appliance.
- Do not spray aerosols in the vicinity of this appliance.
- The stated clearances to combustibles represents a surface temperature of 50° C (90° F) above room temperature. Building materials with a low heat tolerance (such as plastics, vinyl siding, canvas, tri-ply, etc) may be subject to degradation at lower temperatures. **It is the installer's responsibility to assure that adjacent materials are protected from degradation.**
- Maintain clearances from heat sensitive equipment and workstations.
- Maintain clearances from vehicles parked below the heater.
- Maintain clearances from swinging and overhead doors, overhead cranes, vehicle lifts, partitions, storage racks, hoists, building construction, etc.
- In locations used for the storage of combustible materials, signs must be posted to specify the maximum permissible stacking height to maintain required clearances from the heater to the combustibles. Signs must be posted adjacent to the heater thermostat. In the absence of a thermostat, signs must be posted in a conspicuous location.



### 3.2 Clearance Data - Linear and Double Linear

- NOTE:**
1. All dimensions are from the surfaces of all tubes, couplings, tees, elbows and crosses.
  2. Clearances B, C and D can be reduced by 50% after 7500 mm of tubing downstream from the burner.
  3. All measurements are in millimeters.

**FIGURE 3: LINEAR & DOUBLE LINEAR, HORIZONTAL MOUNTS**

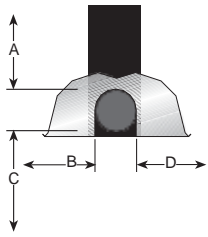

Model	ATH15ST ATH30DL	ATH20ST ATH40DL	ATH25ST ATH50DL	ATH30ST ATH60DL	ATH35ST ATH70DL	ATH40ST	ATH45ST	ATH50ST
A	150	150	150	150	150	150	200	200
B	890	970	970	1020	1170	1220	1280	1330
C	1570	1650	1650	1780	1930	1970	2010	2080
D	890	970	970	1020	1170	1220	1280	1330

**FIGURE 4: LINEAR & DOUBLE LINEAR, ONE SIDE REFLECTOR**

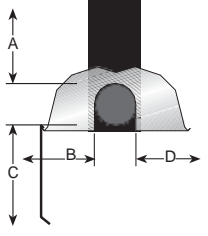

Model	ATH15ST ATH30DL	ATH20ST ATH40DL	ATH25ST ATH50DL	ATH30ST ATH60DL	ATH35ST ATH70DL	ATH40ST	ATH45ST	ATH50ST
A	150	150	150	150	150	150	200	200
B	230	230	230	230	230	230	230	230
C	1580	1760	1760	1930	2090	2130	2160	2240
D	1200	1380	1380	1500	1660	1710	1760	1860

**FIGURE 5: LINEAR & DOUBLE LINEAR, TWO SIDE REFLECTORS**

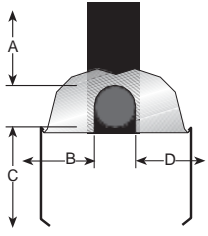

Model	ATH15ST ATH30DL	ATH20ST ATH40DL	ATH25ST ATH50DL	ATH30ST ATH60DL	ATH35ST ATH70DL	ATH40ST	ATH45ST	ATH50ST
A	150	150	150	150	150	150	200	200
B	590	640	640	690	820	860	890	1020
C	1660	1810	1810	1960	2110	2160	2210	2320
D	590	640	640	690	820	860	890	1020

**FIGURE 6: LINEAR & DOUBLE LINEAR, 45° MOUNT**

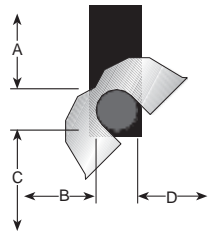

Model	ATH15ST ATH30DL	ATH20ST ATH40DL	ATH25ST ATH50DL	ATH30ST ATH60DL	ATH35ST ATH70DL	ATH40ST	ATH45ST	ATH50ST
A	200	200	200	250	250	275	300	300
B	200	200	200	200	200	200	200	200
C	1500	1660	1660	1860	1960	2030	2110	2160
D	1370	1520	1520	1630	1750	1820	1880	2000

\* ATH55ST only available in multiburner.

- NOTE:** 1. All dimensions are from the surfaces of all tubes, couplings, tees, elbows and crosses.  
 2. Clearances B, C and D can be reduced by 50% after 7500 mm of tubing downstream from the burner.  
 3. All measurements are in millimeters.

**FIGURE 7: LINEAR & DOUBLE LINEAR, 2 FOOT DECO GRILLE**

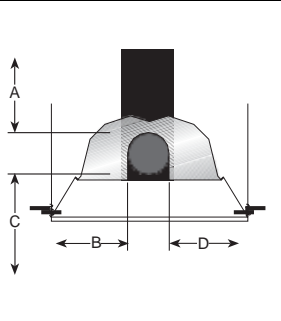

Model	ATH15ST ATH30DL	ATH20ST ATH40DL	ATH25ST ATH50DL	ATH30ST ATH60DL	ATH35ST ATH70DL	ATH40ST	ATH45ST	ATH50ST
A	150	150	150	150	150	150	200	200
B	890	970	970	1020	1170	1220	1280	1330
C	1570	1650	1650	1780	1930	1970	2010	2080
D	890	970	970	1020	1170	1220	1280	1330

**FIGURE 8: LINEAR & DOUBLE LINEAR, PROTECTIVE GRILLE**

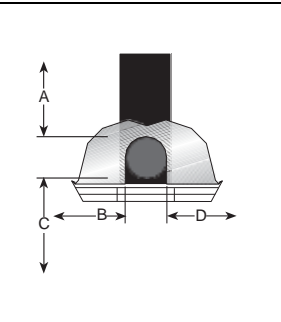

Model	ATH15ST ATH30DL	ATH20ST ATH40DL	ATH25ST ATH50DL	ATH30ST ATH60DL	ATH35ST ATH70DL	ATH40ST	ATH45ST	ATH50ST
A	150	150	150	150	150	150	200	200
B	890	970	970	1020	1170	1220	1280	1330
C	1570	1650	1650	1780	1930	1970	2010	2080
D	890	970	970	1020	1170	1220	1280	1330

**FIGURE 9: UNDERSHIELD \*\***

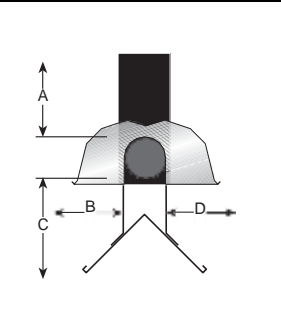

Model	ATH15ST ATH30DL	ATH20ST ATH40DL	ATH25ST ATH50DL	ATH30ST ATH60DL	ATH35ST ATH70DL	ATH40ST	ATH45ST	ATH50ST
A	150	150	150	150	150	150	-	-
B	990	1020	1270	1270	1370	1400	-	-
C	840	965	1120	1120	1220	1270	-	-
D	990	1020	1270	1270	1370	1400	-	-

\*\* When installed in the first 6 m - Not for use on EF models.

**FIGURE 10: LINEAR & DOUBLE LINEAR, VENTING**

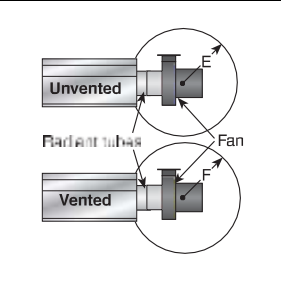

Model	ATH15ST ATH30DL	ATH20ST ATH40DL	ATH25ST ATH50DL	ATH30ST ATH60DL	ATH35ST ATH70DL	ATH40ST	ATH45ST	ATH50ST
E	1000	1000	1000	1000	1000	1000	1000	1000
F	500	500	500	500	500	500	500	500

\* ATH55ST only available in multiburner.

3.3 Clearance Data -U Tube

- NOTE:** 1. All dimensions are from the surfaces of all tubes, couplings, tees, elbows and crosses.  
 2. Clearances B, C and D can be reduced by 50% after 7500 mm of tubing downstream from the burner.  
 3. All measurements are in millimeters.  
 4. Add 60 mm clearance to uncovered U-tube.

**FIGURE 11: U-TUBE, HORIZONTAL MOUNT**

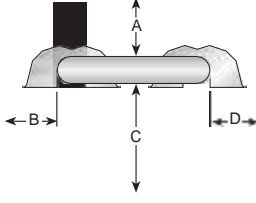

Model	ATH15UT	ATH20UT	ATH25UT	ATH30UT	ATH35UT	ATH40UT	ATH45UT	ATH50UT
A	150	150	150	150	150	150	200	200
B	890	970	970	1020	1170	1220	1270	1380
C	1580	1730	1730	1910	1980	2050	2110	2210
D	760	940	940	1000	1090	1150	1200	1300

**FIGURE 12: U-TUBE, ONE SIDE REFLECTOR**

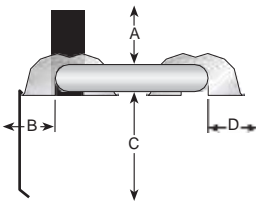

Model	ATH15UT	ATH20UT	ATH25UT	ATH30UT	ATH35UT	ATH40UT	ATH45UT	ATH50UT
A	150	150	150	150	150	150	200	200
B	230	230	230	230	230	230	230	230
C	1580	1760	1760	1930	2090	2130	2160	2240
D	1200	1380	1380	1500	1660	1710	1760	1860

**FIGURE 13: U-TUBE, TWO SIDE REFLECTORS**

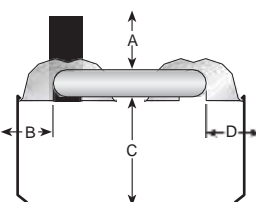

Model	ATH15UT	ATH20UT	ATH25UT	ATH30UT	ATH35UT	ATH40UT	ATH45UT	ATH50UT
A	150	150	150	150	150	150	200	200
B	590	640	640	690	820	860	890	1020
C	1660	1810	1810	1960	2110	2160	2210	2320
D	590	640	640	690	820	860	890	1020

**FIGURE 14: U-TUBE, FULL 45° MOUNT**

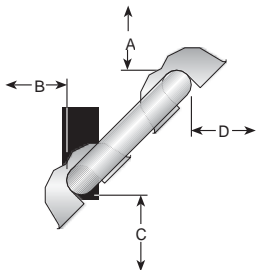

Model	ATH15UT	ATH20UT	ATH25UT	ATH30UT	ATH35UT	ATH40UT	ATH45UT	ATH50UT
A	200	200	200	200	200	200	200	200
B	200	200	200	200	200	200	200	200
C	1500	1650	1650	1860	1960	2040	2110	2160
D	1070	1170	1170	1320	1550	1620	1680	1780

- NOTE:** 1. All dimensions are from the surfaces of all tubes, couplings, tees, elbows and crosses.  
 2. Clearances B, C and D can be reduced by 50% after 7500 mm of tubing downstream from the burner.  
 3. All measurements are in millimeters.  
 4. Add 60 mm clearance to uncovered U-tube.

**FIGURE 15: U-TUBE, OPPOSITE 45° TILT**

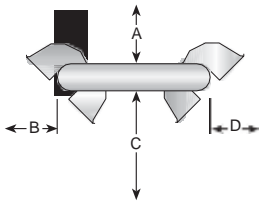
	Model	ATH15UT	ATH20UT	ATH25UT	ATH30UT	ATH35UT	ATH40UT	ATH45UT	ATH50UT
	A	200	200	200	250	250	275	300	300
B	1370	1530	1530	1630	1780	1830	1880	1930	
C	1500	1650	1650	1860	1960	2040	2110	2160	
D	560	560	560	560	560	560	560	560	

**FIGURE 16: U-TUBE, PROTECTIVE GRILLE**

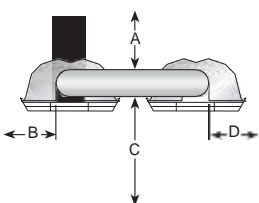
	Model	ATH15UT	ATH20UT	ATH25UT	ATH30UT	ATH35UT	ATH40UT	ATH45UT	ATH50UT
	A	150	150	150	150	150	150	200	200
B	890	970	970	1020	1170	1220	1270	1380	
C	1580	1730	1730	1910	1980	2050	2110	2210	
D	760	940	940	1000	1090	1150	1200	1300	

**FIGURE 17: U-TUBE, VENTING**

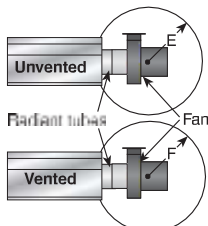
	Model	ATH15UT	ATH20UT	ATH25UT	ATH30UT	ATH35UT	ATH40UT	ATH45UT	ATH50UT
	E	1000	1000	1000	1000	1000	1000	1000	1000
F	500	500	500	500	500	500	500	500	

**SECTION 4: MAJOR COMPONENT DESCRIPTIONS**



**Burner (shown with Tube Gasket)**

Must be installed with the flame observation window facing down.

**Reflector (Aluminium or Stainless Steel)**

Alternate overlap as shown on overview. Minimum overlap is 160 mm.

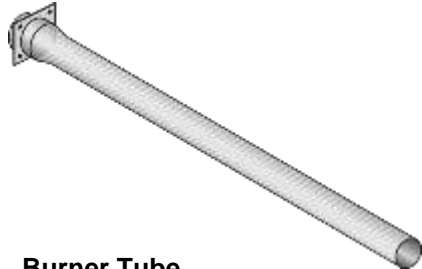

**Burner Tube**

Supplied in 3,000 mm lengths. Burner tube is always the first tube after the burner.

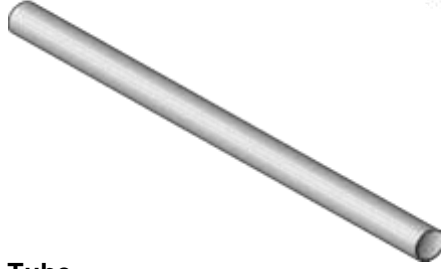

**Tube**

Heat treated aluminised tube supplied in 3,000 mm lengths.



**Fan Tube with Internal Swirler**

Supplied in 3,000 mm lengths. Fan tube is always the last tube on the heater where the fan is attached. The swirler is welded to the inside of the tube end.



**Tube and Reflector Hanger with Clamp Package**

Position this hanger no more than 100 mm away from the burner assembly.



**Coupling Assembly with Lock**



**Tube and Reflector Hanger**

Suspend system from these hangers.

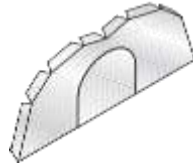

**Reflector End Cap**

Punch out center section to accommodate tube.



**Reflector Support Strap, Wire Form & #8 x 3/4 (3.9 x 19mm) Screw**

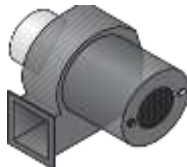

**Fan Assembly (Includes Flange)**

Fan Assembly is attached to the last section of heat exchanger tubing (Fan Tube).



**Flex Gas Line**

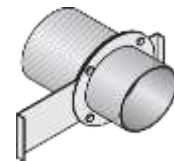

**Damper Flange Assembly**

For use on Multiburner Systems.



**Tee Assembly**

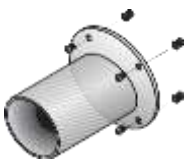

**Fan Flange Assembly and Screws**



**U-Tube**



**S-hook**



**Height Adjuster**

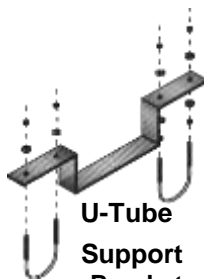

**U-Tube Support Bracket**



**Spring Hook**



**Bow Shackle**

## SECTION 5: GENERAL SUSPENSION DETAILS

**WARNING****Severe Injury Hazard**

**Secure burner to burner tube with bolts and lockwashers.**

**Hang heater with materials with a minimum working load of 75 lbs (33 kg).**

**Failure to follow these instructions can result in death, injury or property damage.**

**WARNING****Cut/Pinch Hazard**

**Wear protective gear during installation, operation and service.**

**Edges are sharp.**

**Failure to follow these instructions can result in injury.**

To ensure your safety, and comply with the terms of the warranty, all units must be installed in accordance with these instructions.

The gas or the electrical supply lines must not be used to support the heater.

Do not locate the gas or electric supply lines directly over the path of the flue products from the heater.

The heater must be installed in a location that it is readily accessible for servicing.

The heater must be installed in accordance with clearances to combustibles as indicated in this manual.

The minimum and maximum gas inlet pressures must be maintained as indicated on the rating plate. Typical installation configurations are shown *on Page 12, Figure 18*.

Suspension chain is not supplied as standard equipment.

Note: Some models will receive S-hooks (P/N 91907302) or spring hooks (P/N 91903300), rather than bow shackles.

Figure 18: Critical Hanger Placement

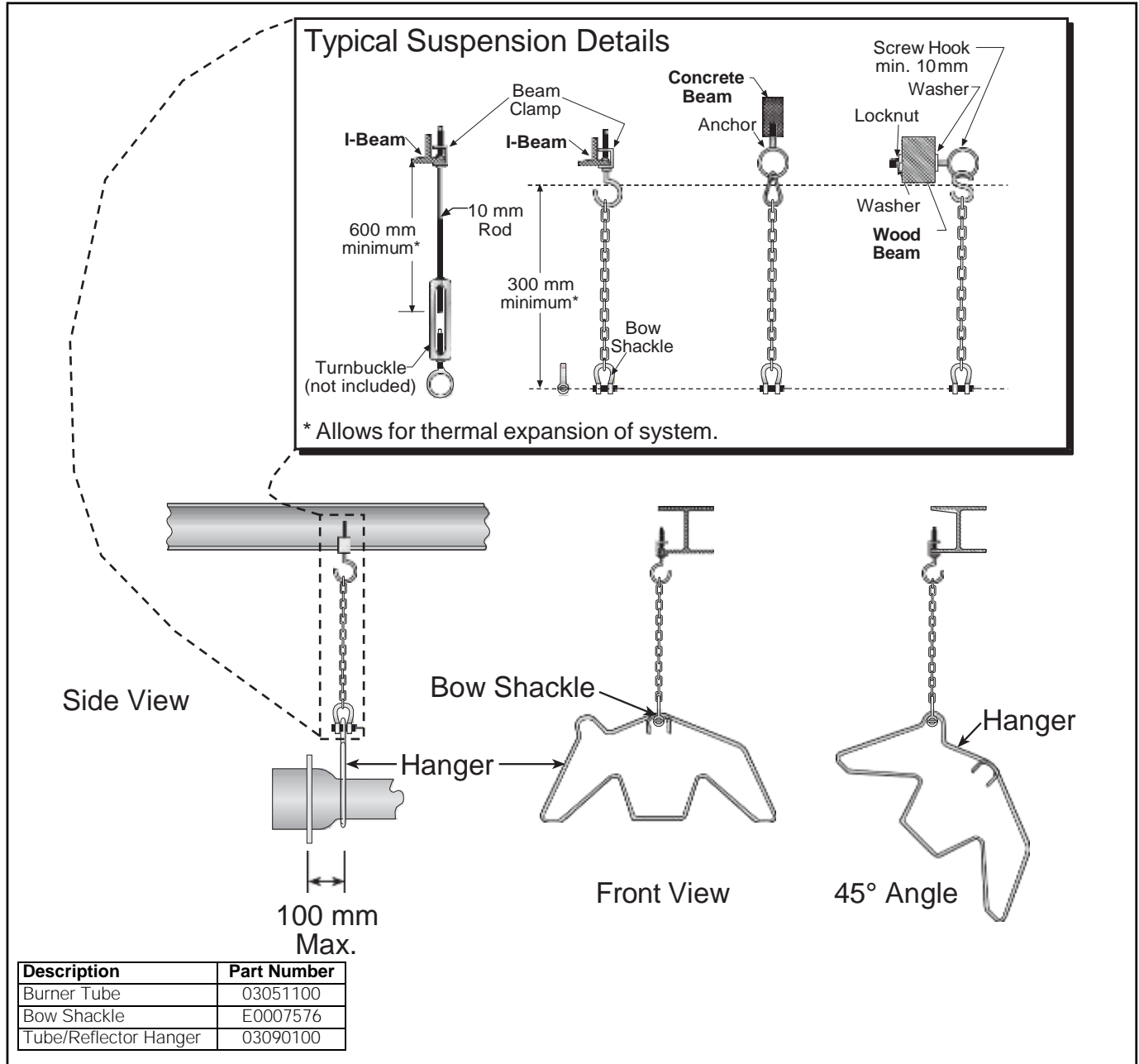

For suspension angles other than shown, additional chain supports may be required.

## SECTION 6: LINEAR &amp; DOUBLE LINEAR HEATER INSTALLATION

**⚠ WARNING**



**Cut/Pinch Hazard**

**Wear protective gear during installation, operation and service.**

**Edges are sharp.**

**Failure to follow these instructions can result in injury.**

The figures in this section provide a general overview of component placement in a Linear and Double Linear system. The location of some components such as supports and couplings is crucial for proper installation. Assemble the heater components as shown *on Page 14, Figure 19*.

For optional reflector configurations for linear heaters see *Page 6, Figure 3 through Page 7, Figure 10*. Install appropriate suspension hardware, beam clamps, chain or rod at predetermined locations. Adjustments of chain length will provide uniform pitch.

If any step is unclear, please contact Aira at +61 3 9839 8000.

## 6.1 Linear Standard Parts List

Part No.	Description	ATH15ST	ATH20ST	ATH25ST	ATH30ST	ATH35ST	ATH40ST	ATH45ST	ATH50ST
ATH72XXXXX	Burner Assembly (Input and Fuel Varies)	1	1	1	1	1	1	1	1
07260001	Fan Package XP 1	1	1	1	1	-	-	-	-
07260002	Fan Package XP2	-	-	-	-	1	1	1	-
07260003	Fan Package XP 3	-	-	-	-	-	-	-	1
03051100	Burner Tube, 100 mm x 3048 mm	1	1	1	1	1	1	1	1
91409408	Tube, 100 mm x 3048 mm	-	1	1	2	2	2	3	3
S5127W	Fan Tube, 100 mm x 3048 mm, with 3048 mm Swirler	-	1	1	1	1	1	1	1
S5134W	Fan Tube, 100 mm x 3048 mm, with 2134 mm Swirler	1	-	-	-	-	-	-	-
01329600	Standard Coupling Assembly	1	2	2	3	3	3	4	4
01329700	Coupling Lock	1	2	2	3	3	3	4	4
02750303	Reflector, Aluminium, 2439 mm	3	4	4	6	6	6	7	7
027503SS	Reflector, Stainless Steel, 2439 mm (Optional)*	3	4	4	6	6	6	7	7
02750800	Reflector End Cap, Aluminium	2	2	2	2	2	2	2	2
027508SH	Reflector End Cap, Stainless (Optional)*	2	2	2	2	2	2	2	2
03090100	Tube and Reflector Hanger	3	4	4	5	5	5	6	6
01318901	Tube Clamp Package (including Nut, Washer & Bolt)	1	1	1	1	1	1	1	1
91908004	Wire Form	2	3	3	5	5	5	6	6
94320812	Screw #8 x 3/4 (3.9 mm x 19 mm), (goes with 03050000)	4	6	6	10	10	10	12	12
03050000	Reflector Support Strap	2	3	3	5	5	5	6	6
E0007576	Bow Shackle**	3	4	4	5	5	5	6	6
91107720	U-Clip Package (20 Pieces)	1	1	1	1	1	1	1	1
S7199K	Damper Flange Assembly (For use on Multiburner Systems)	1 Per Heater							

\* PVC coating must be removed prior to installation.

\*\* Some models may receive S-hooks (P/N 91907302) or spring hooks (P/N 91903300), rather than bow shackles.



Figure 19: Linear General Assembly Overview

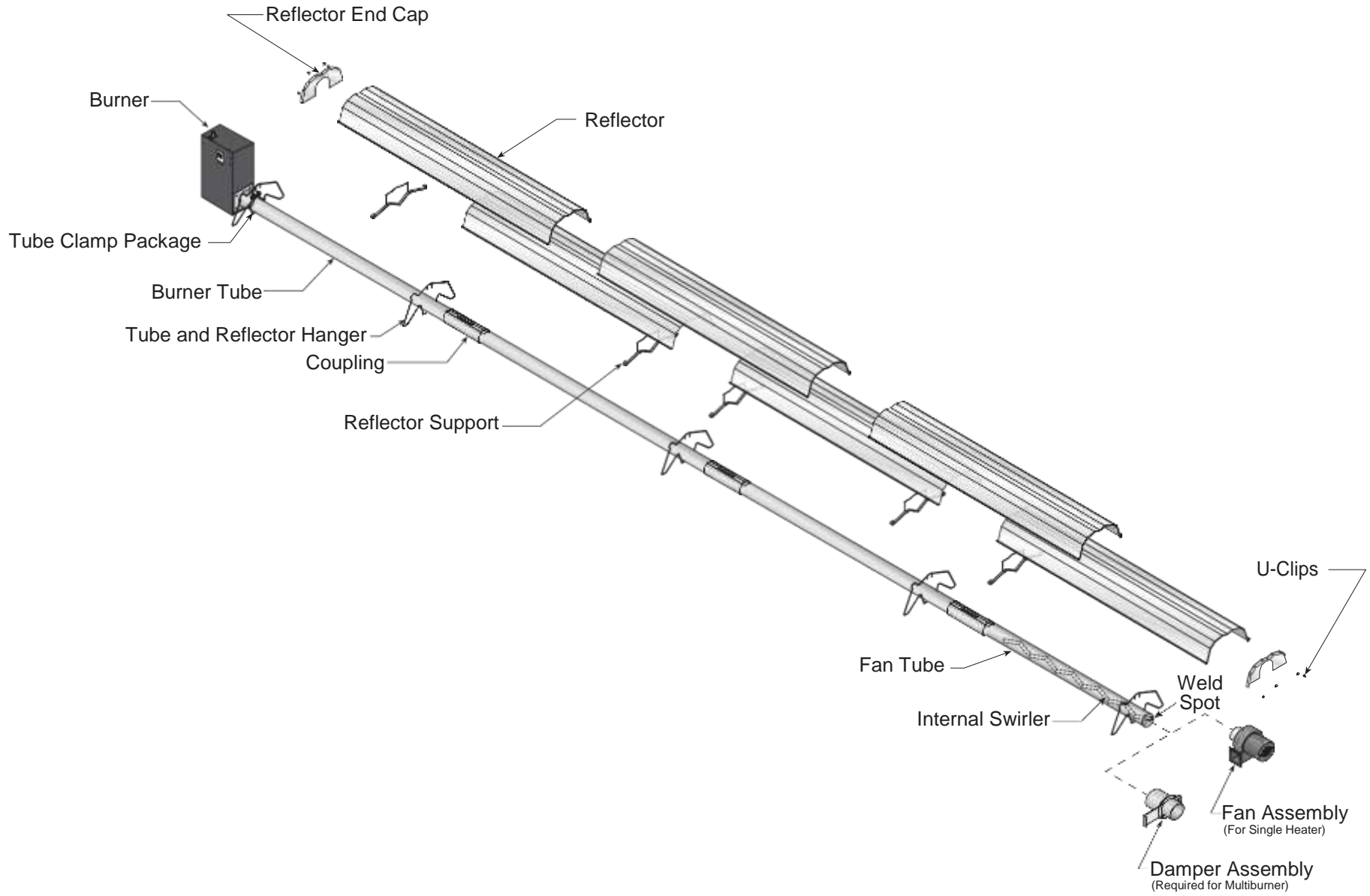
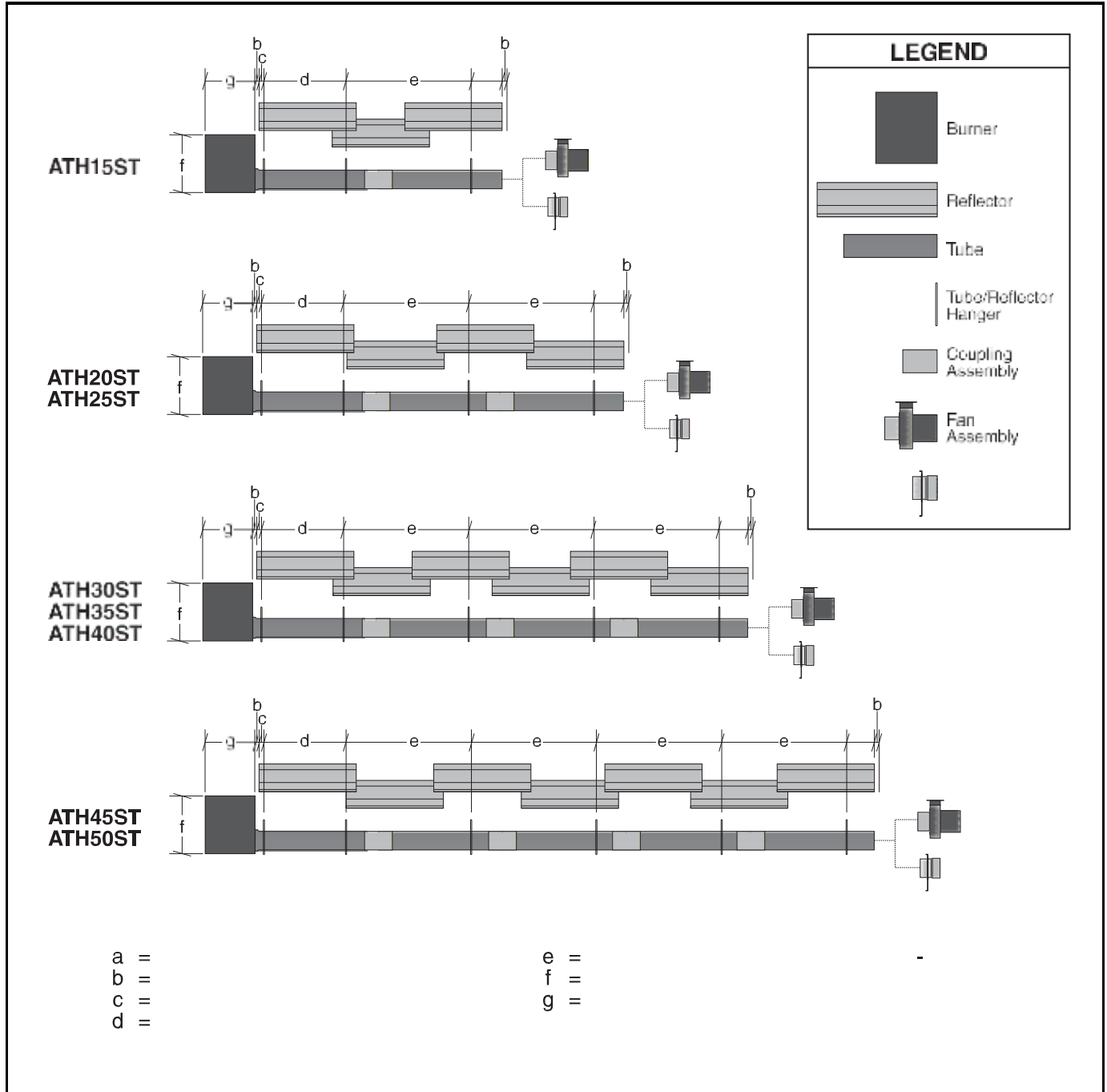

Figure 20: Linear Layout Overview



Model	ATH15ST	ATH20ST	ATH25ST	ATH30ST	ATH35ST	ATH40ST	ATH45ST	ATH50ST
Reflector Overlap (approx.)	700 mm	250 mm	250 mm	530 mm	530 mm	530 mm	330 mm	330 mm

## 6.2 Double Linear Standard Parts List

Part No.	Description	ATH30DL	ATH40DL	ATH50DL	ATH60DL	ATH70DL
ATH72XXXXX	Burner Assembly (Input and Fuel Varies)	2	2	2	2	2
07260002	Fan Package XP2	1	1	-	-	-
07260003	Fan Package XP3	-	-	1	1	1
03051100	Burner Tube, 100 mm x 3048 mm	2	2	2	2	2
91409408	Tube, 100 mm x 3048 mm	-	2	2	4	4
S5127W	Fan Tube, 100 mm x 3048 mm, with 3048 mm Swirler	-	2	2	2	2
S5134W	Fan Tube, 100 mm x 3048 mm, with 2134 mm Swirler	2	-	-	-	-
01330203	Tee, 100 mm x 100 mm x 100 mm	1	1	1	1	1
01329600	Standard Coupling Assembly	4	6	6	8	8
01329700	Coupling Lock	4	6	6	8	8
02750303	Reflector, Aluminium, 2439 mm	6	8	8	12	12
027503SS	Reflector, Stainless Steel, 2439 mm (Optional)*	6	8	8	12	12
02750800	Reflector End Cap, Aluminium	4	4	4	4	4
027508SH	Reflector End Cap, Stainless (Optional)*	4	4	4	4	4
03090100	Tube and Reflector Hanger	6	8	8	10	10
01318901	Tube Clamp Package (including Nut, Washer & Bolt)	2	2	2	2	2
91908004	Wire Form	4	6	6	10	10
03050000	Reflector Support Strap	4	6	6	10	10
E0007576	Bow Shackle**	6	8	8	10	10
91107720	U-Clip Package (20 Pieces)	2	2	2	2	2
E0007582	Height Adjuster	6	8	8	10	10
94320812	Screw #8 x 3/4 (3.9 mm x 19 mm), (goes with 03050000)	8	12	12	20	20

\* PVC coating must be removed prior to installation.

\*\*Some models may receive S-hooks (P/N 91907302) or spring hooks (P/N 91903300), rather than bow shackles

Figure 21: Double Linear General Assembly Overview

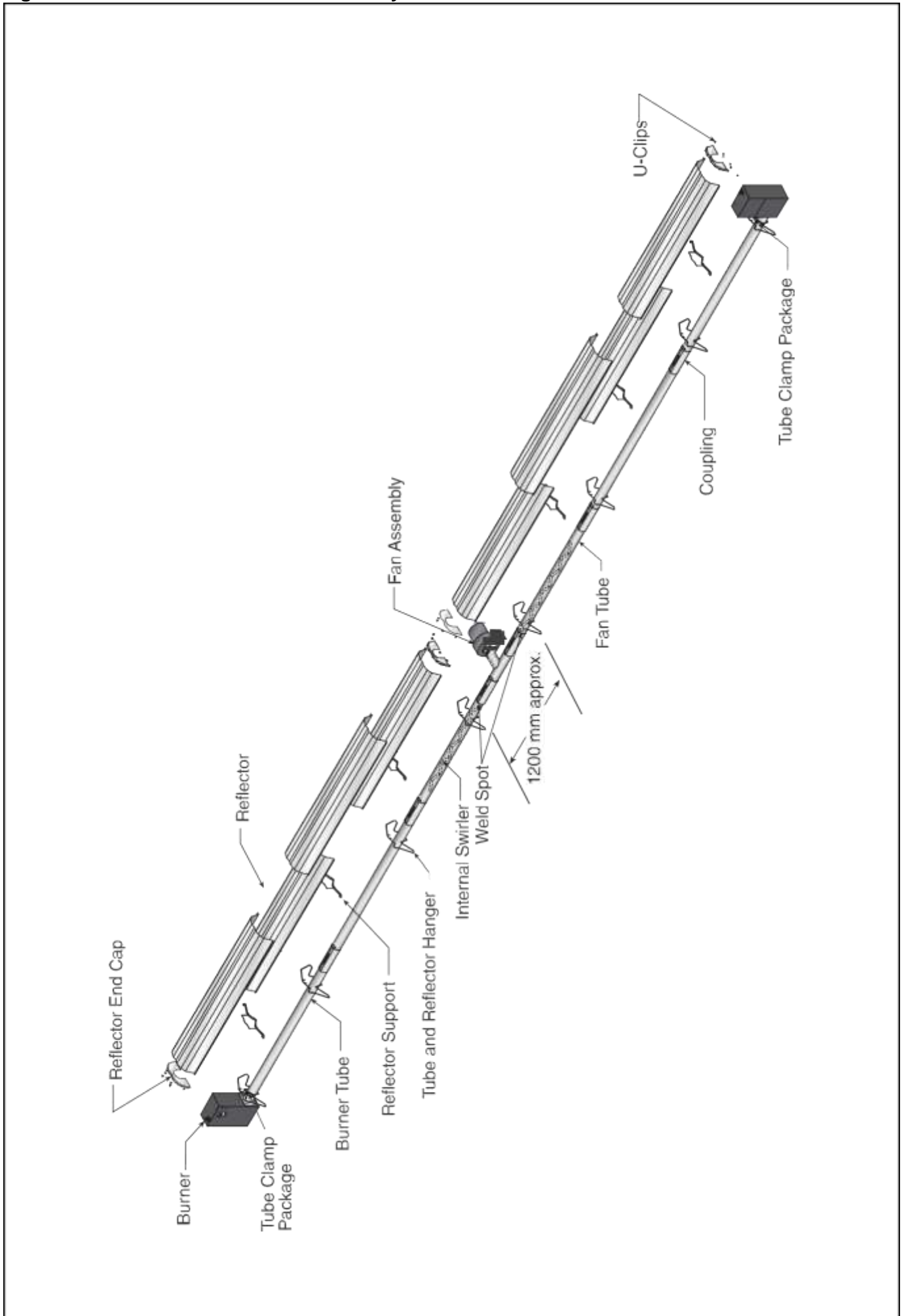
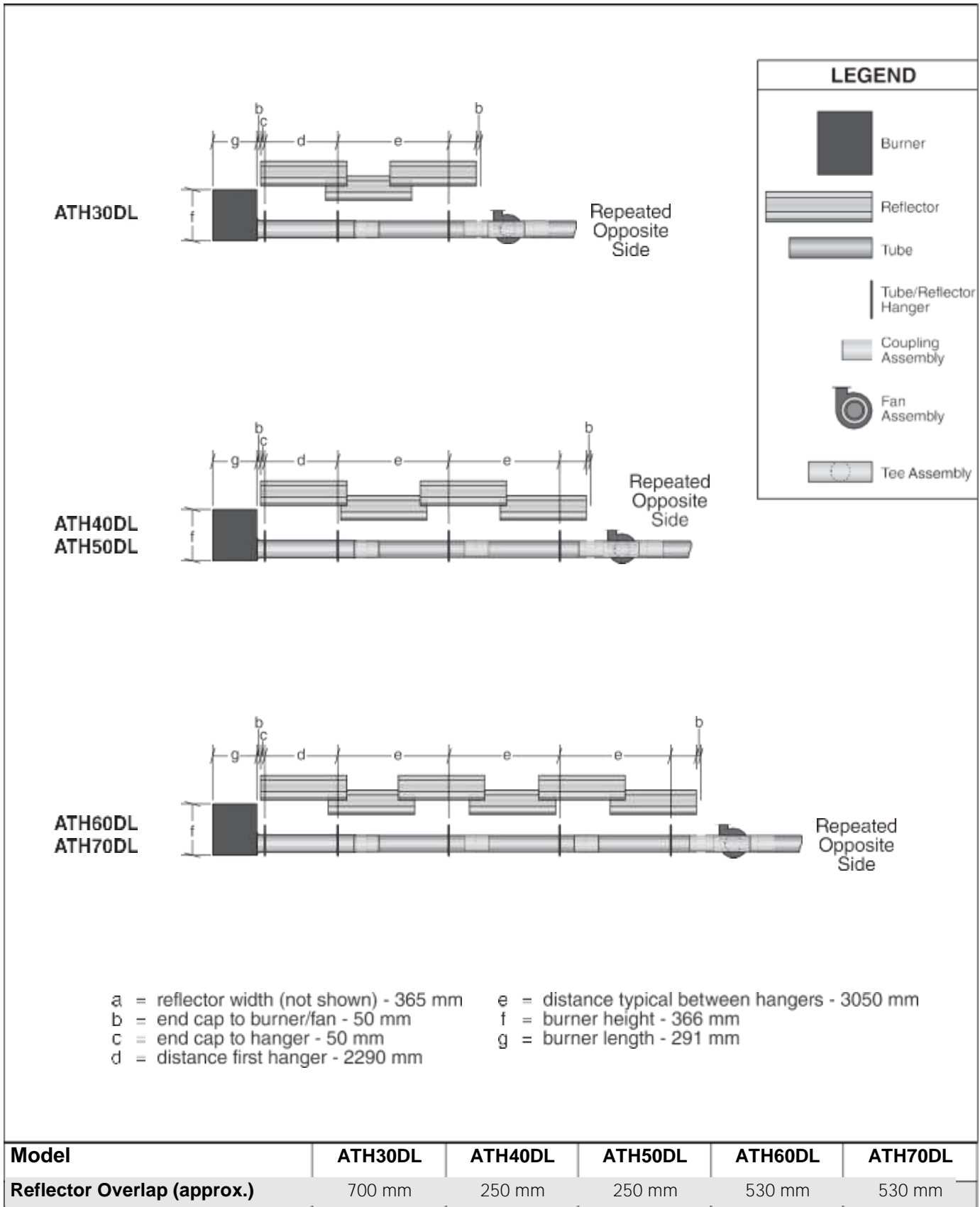

Figure 22: Double Linear Layout Overview



**Step 6.3 Burner Tube Installation**

Note:  
Tubing requires a downward slope of 13 mm per 6000 mm away from burner.

Bow Shackle  
Hanger  
Burner Tube  
2290 mm ± 250 mm

Description	Part Number
Burner Tube	03051100
Bow Shackle	E0007576
Tube/Reflector Hanger	03090100

**Step 6.4 Coupling and Tube Assembly**

**A** Close coupling with tab.

Open  
Closed  
Tab

**B** Start slide bar/coupling lock onto coupling.

Slide Bar  
Wide End Coupling  
76 mm to 101 mm

**C** Insert tubes into coupling.

Tube  
Tube  
Orient coupling so that the impact block is in the 2:00 or 10:00 o'clock positions

**D** Tighten coupling to join tubes.

Slide Bar  
Coupling  
Tube

Description	Part Number
Coupling	01329600
Slide Bar/Coupling Lock	01329700
Tube	91409408

**Step 6.4.1 Coupling and Tube Assembly (Continued)**

Tighten slide bar as shown below.

Drive slide bar until tight.  
End of slide bar should be within tolerance listed below.

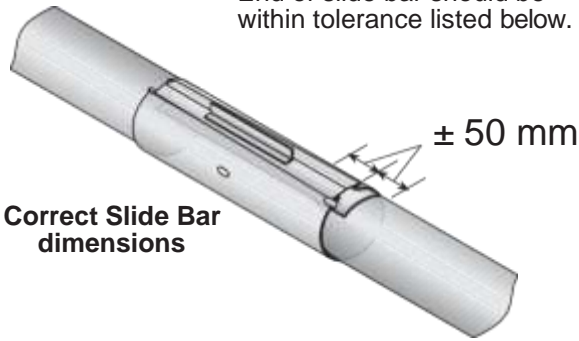

- Repeat Step 6.4 A - D until all tubes are assembled. See Page 20, Section 6.4.2 shown below.

**Step 6.4.2 Coupling and Tube Assembly (Continued)**

Model	Overall Tube Length (mm)	Number of Tubes
ATH15ST	6,000	2
ATH20ST	9,000	3
ATH25ST	9,000	3
ATH30ST	12,000	4
ATH35ST	12,000	4
ATH40ST	12,000	4
ATH45ST	15,000	5
ATH50ST	15,000	5

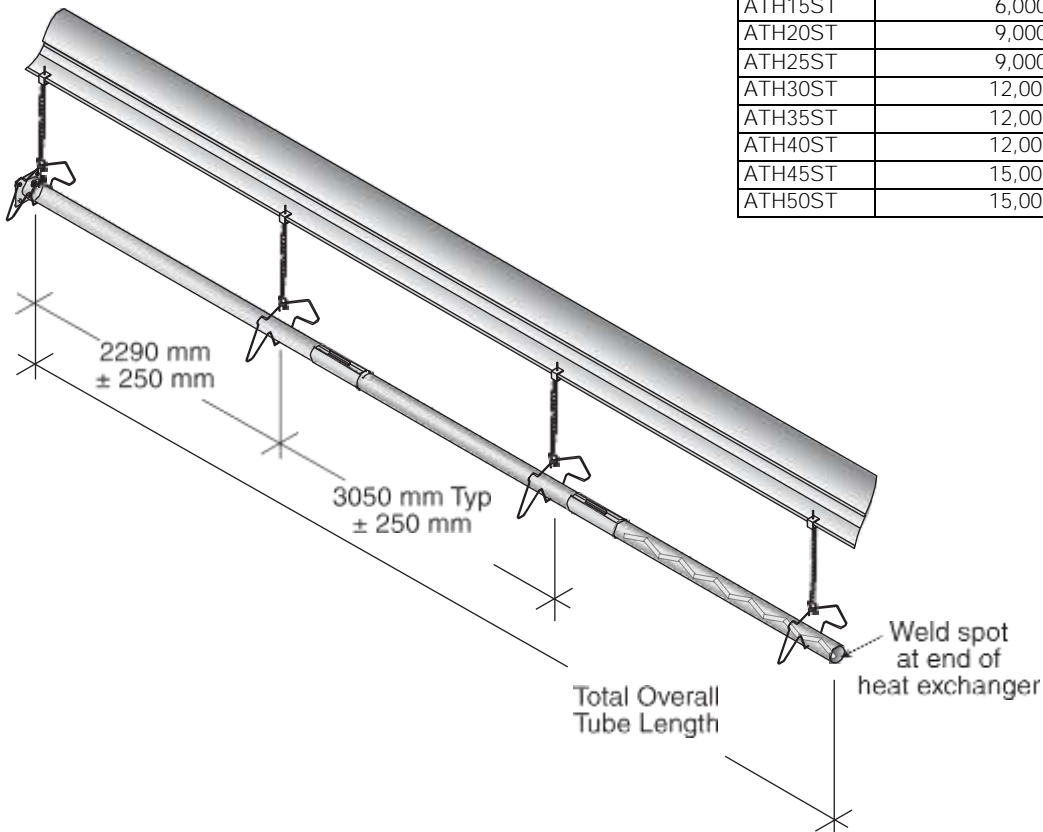

## Step 6.5 Tube Clamp Package Installation

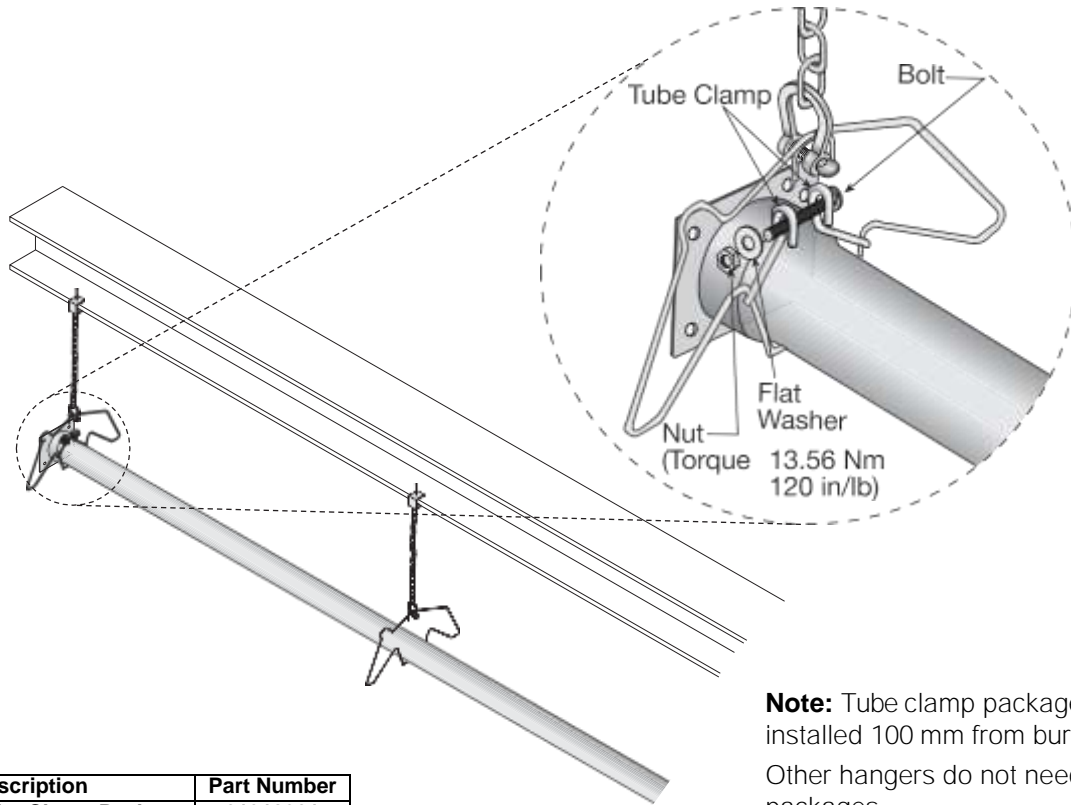

**Note:** Tube clamp package should be installed 100 mm from burner tube plate. Other hangers do not need tube clamp packages.

Description	Part Number
<b>Tube Clamp Package</b>	<b>01318901</b>
Tube Clamp	01396801
Bolt	97113940
Flat Washer	95211600
Nut	92113900



Step 6.6 Reflector Installation

**⚠ WARNING**



**Fire Hazard**

Support reflector with reflector hanger and support strap.

Reflector must not touch tube.

Failure to follow these instructions can result in death, injury or property damage.

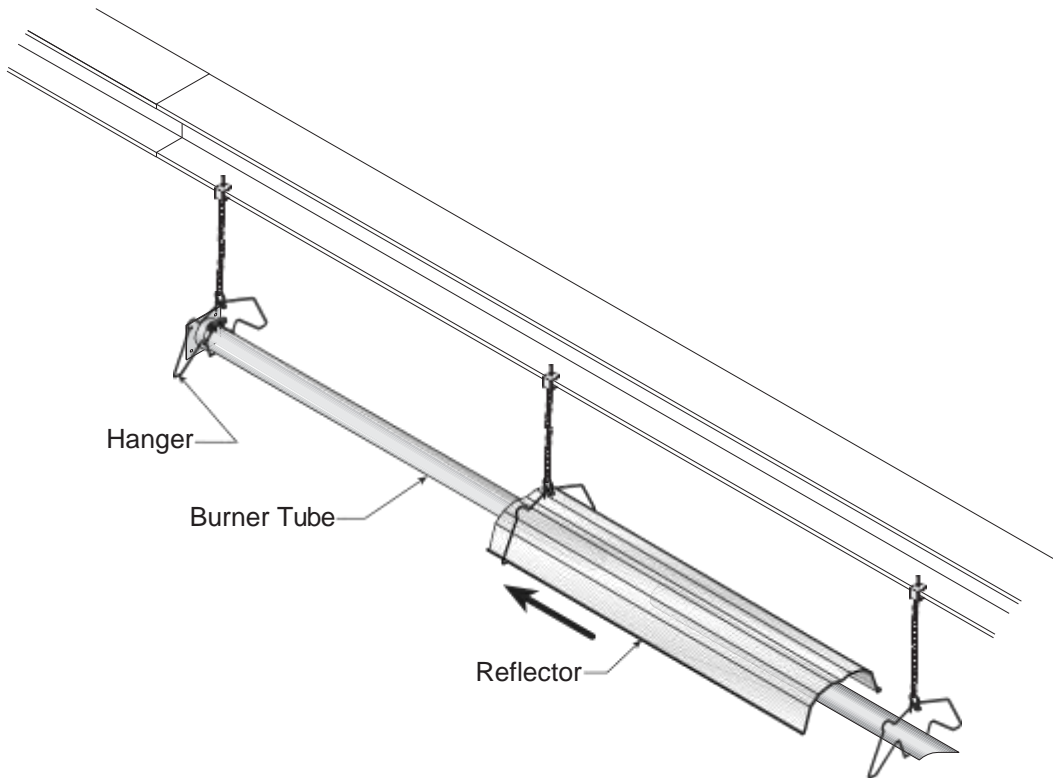

Description	Part Number
Tube/Reflector Hanger	03090100
Burner Tube	03051100
Reflector	02750303

### Step 6.6.1 Reflector, U-Clip and Reflector Support Installation

The pictorial drawings of the heater construction in **Section 6** are schematic only and provide a general guideline of where hangers, reflector supports and U-clips are to be installed.

To ensure proper expansion and contraction movement of the reflectors, a combination of U-clips and reflector

supports are used. The positioning of reflector supports and U-clips depend on the individual installation. Use either pop rivets or sheet metal screws instead of U-clips when installing end caps and joint pieces in areas where impact and high wind may be a factor. The following rules must be observed:

1. The first reflector after the burner must be affixed in the middle of the reflector with a reflector support and tight screws.

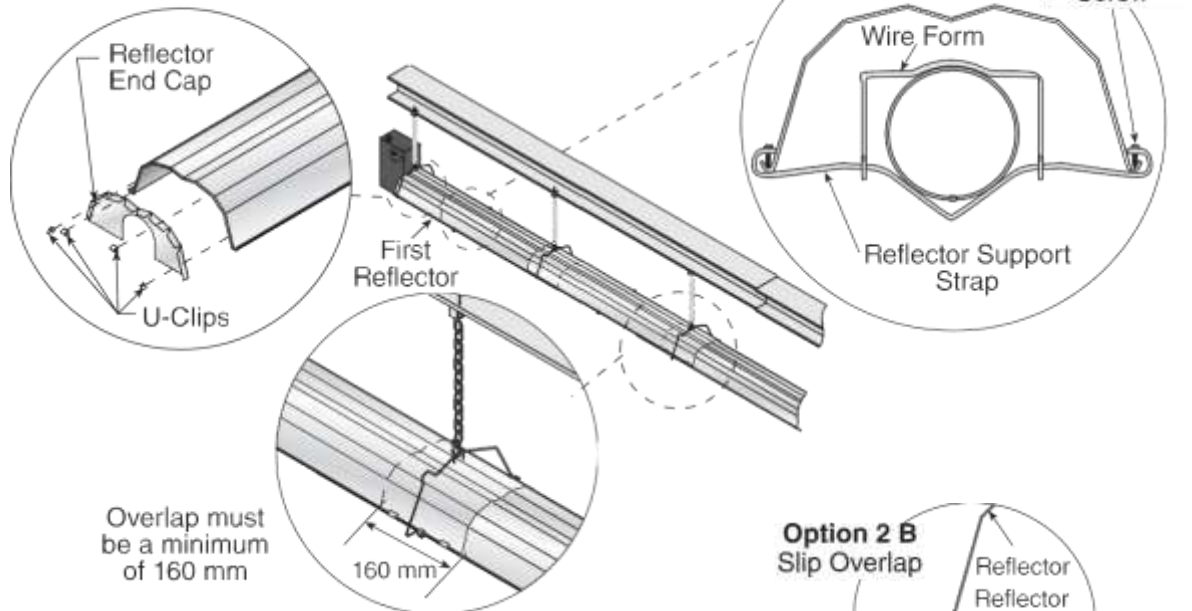

- 2 The overlap at the first and second reflector is a slip overlap. Thereafter, every third reflector joint is a slip overlap. A slip overlap is achieved by either:
- both reflectors lay inside a hanger. (no reflector support needed).
  - using a reflector support with loose screws at the reflector overlap.

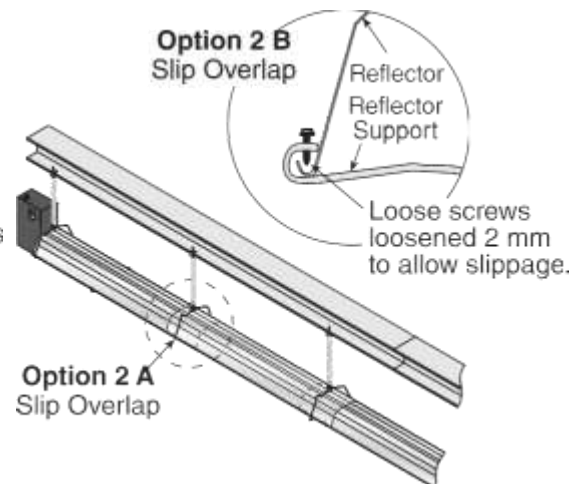

- 3 The remaining reflector overlaps require a non-slip overlap connection. To affix the reflectors together in a non-slip overlap either:
- use reflector support and tight screws.
  - if both reflectors lay inside a hanger, u-clips or sheet metal screws may be used.

This section of three reflectors joined together must be affixed to the tube with at least one reflector support with tight screws.

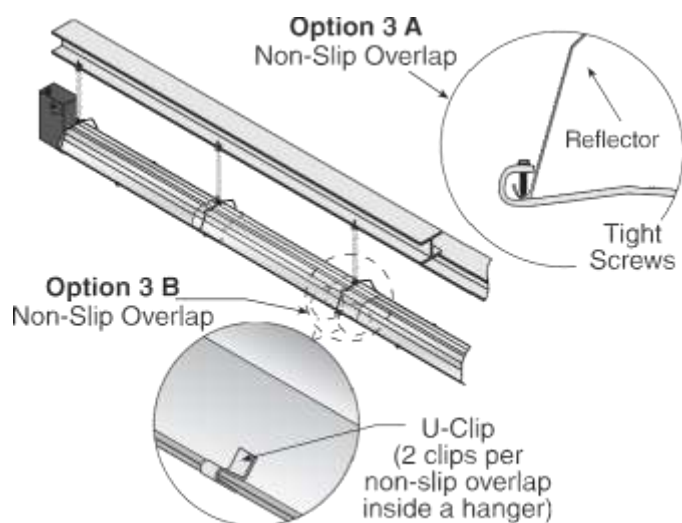

Description	Part Number
<b>Reflector Support Package</b>	<b>03050010</b>
Wire Form	91908004
Reflector Support Strap	03050000
Screw #8 x 3/4	94320812
U-Clip Package	91107720
Reflector End Cap	027508XX

**Step 6.7 Double Linear Tee Installation (for double linear heaters only)**

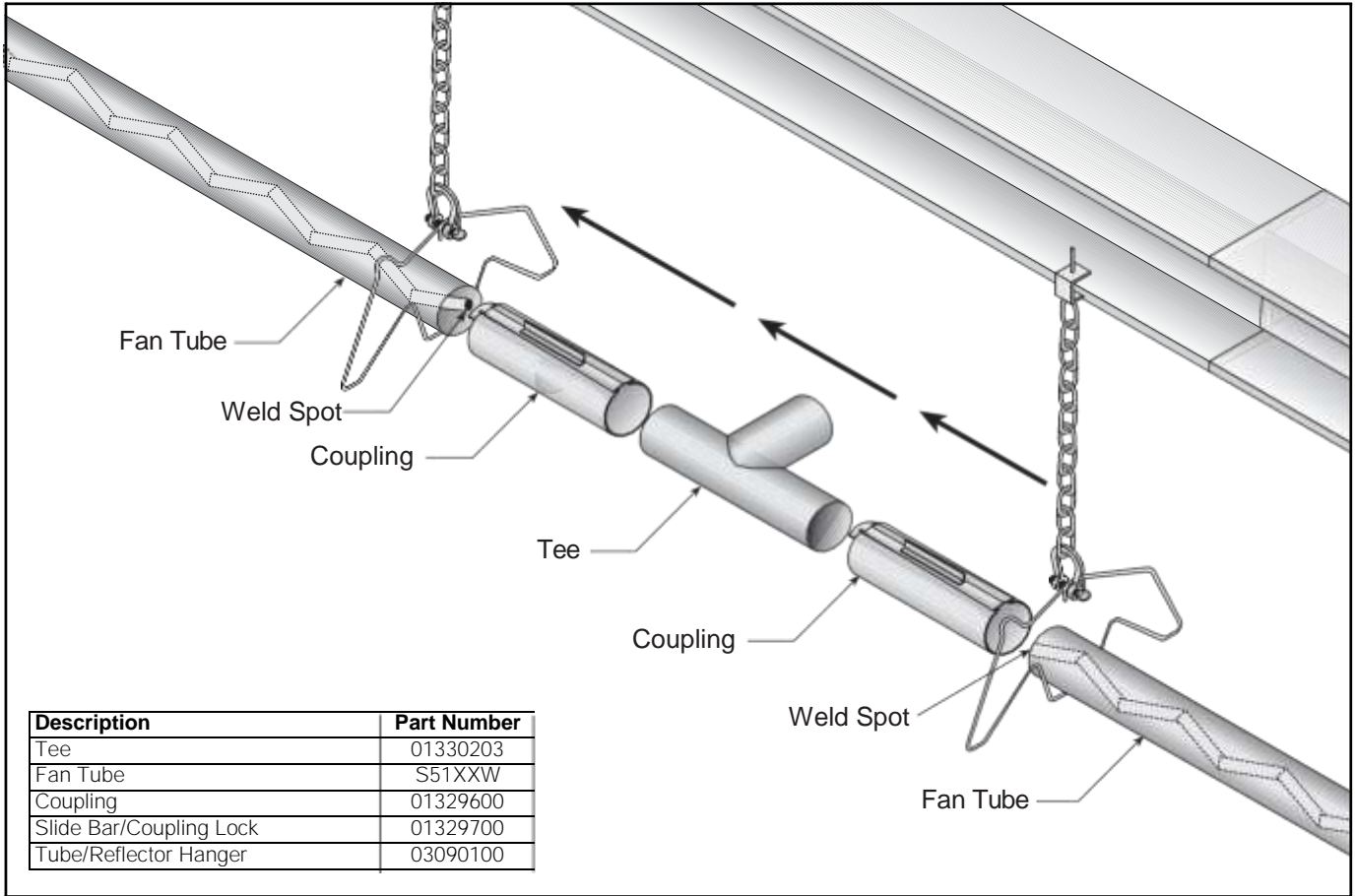

## SECTION 7: U-TUBE HEATER INSTALLATION

**WARNING****Cut/Pinch Hazard**

**Wear protective gear during installation, operation and service.**

**Edges are sharp.**

**Failure to follow these instructions can result in injury.**

The figures in this section provide a general overview of component placement in a U-tube system. The location of some components such as supports and couplings is crucial for proper installation. Assemble the heater components as shown *on Page 26, Figure 23*.

For optional reflector configurations for U-tube heaters, *See Page 8, Figure 11 through Page 9, Figure 17*. Install appropriate suspension hardware, beam clamps, chain or rod at predetermined locations. Adjustments of chain length will provide uniform pitch.

If any step is unclear, please contact Aira at +61 3 9839 8000.

## 7.1 U-Tube Standard Parts List

Part No.	Description	ATH15UT	ATH20UT	ATH25UT	ATH30UT	ATH35UT	ATH40UT	ATH45UT	ATH50UT
ATH72XXXXX	Burner Assembly (Input and Fuel Varies)	1	1	1	1	1	1	1	1
07260001	Fan Package XP1	1	1	1	1	-	-	-	-
07260002	Fan Package XP2	-	-	-	-	1	1	1	-
07260003	Fan Package XP3	-	-	-	-	-	-	-	1
03051100	Burner Tube, 100 mm x 3048 mm	1	1	1	1	1	1	1	1
91409408	Tube, 100 mm x 3048 mm	-	-	-	2	2	2	2	2
91409423	Tube, 100 mm x 1524 mm	-	2	2	-	-	-	2	2
S5127W	Fan Tube, 100mm x 3048 mm, with 3048 mm Swirler	-	1	1	1	1	1	1	1
S5134W	Fan Tube, 100mm x 3048 mm, with 2134 mm Swirler	1	-	-	-	-	-	-	-
01335901	U-Bend	1	1	1	1	1	1	1	1
01329600	Standard Coupling Assembly	2	4	4	4	4	4	6	6
01329700	Coupling Lock	2	4	4	4	4	4	6	6
02750303	Reflector, Aluminium, 2439 mm	4	4	4	6	6	6	8	8
027503SS	Reflector, Stainless Steel, 2439 mm (Optional)*	4	4	4	6	6	6	8	8
02750800	Reflector End Cap, Aluminium	4	4	4	4	4	4	4	4
027508SH	Reflector End Cap, Stainless (Optional)*	4	4	4	4	4	4	4	4
03090100	Tube and Reflector Hanger	4	6	6	6	6	6	8	8
01318901	Tube Clamp Package (including Nut, Washer & Bolt)	1	1	1	1	1	1	1	1
91908004	Wire Form	2	4	4	4	4	4	6	6
03050000	Reflector Support Strap	2	4	4	4	4	4	6	6
03020501	U-Bend Support Bracket	1	1	1	1	1	1	1	1
E0007576	Bow Shackle**	4	6	6	6	6	6	8	8
91107720	U-Clip Package (20 Pieces)	2	2	2	2	2	2	2	2
91912501	U-Bolt M6	2	2	2	2	2	2	2	2
C0090B	Nut M6	6	6	6	6	6	6	6	6
96411500	Lockwasher 6 mm	6	6	6	6	6	6	6	6
94320812	Screw#8x3/4(3.9mmx19mm),(goes with 03050000)	4	8	8	8	8	8	12	12
S7199K	Damper Flange Assembly (For use on Multiburner Systems)	1 Per Heater							

\*PVC coating must be removed prior to installation.

\*\*Some models may receive S-hooks (P/N 91907302) or spring hooks (P/N 91903300), rather than bow shackles

Figure 23: U-Tube Assembly Overview

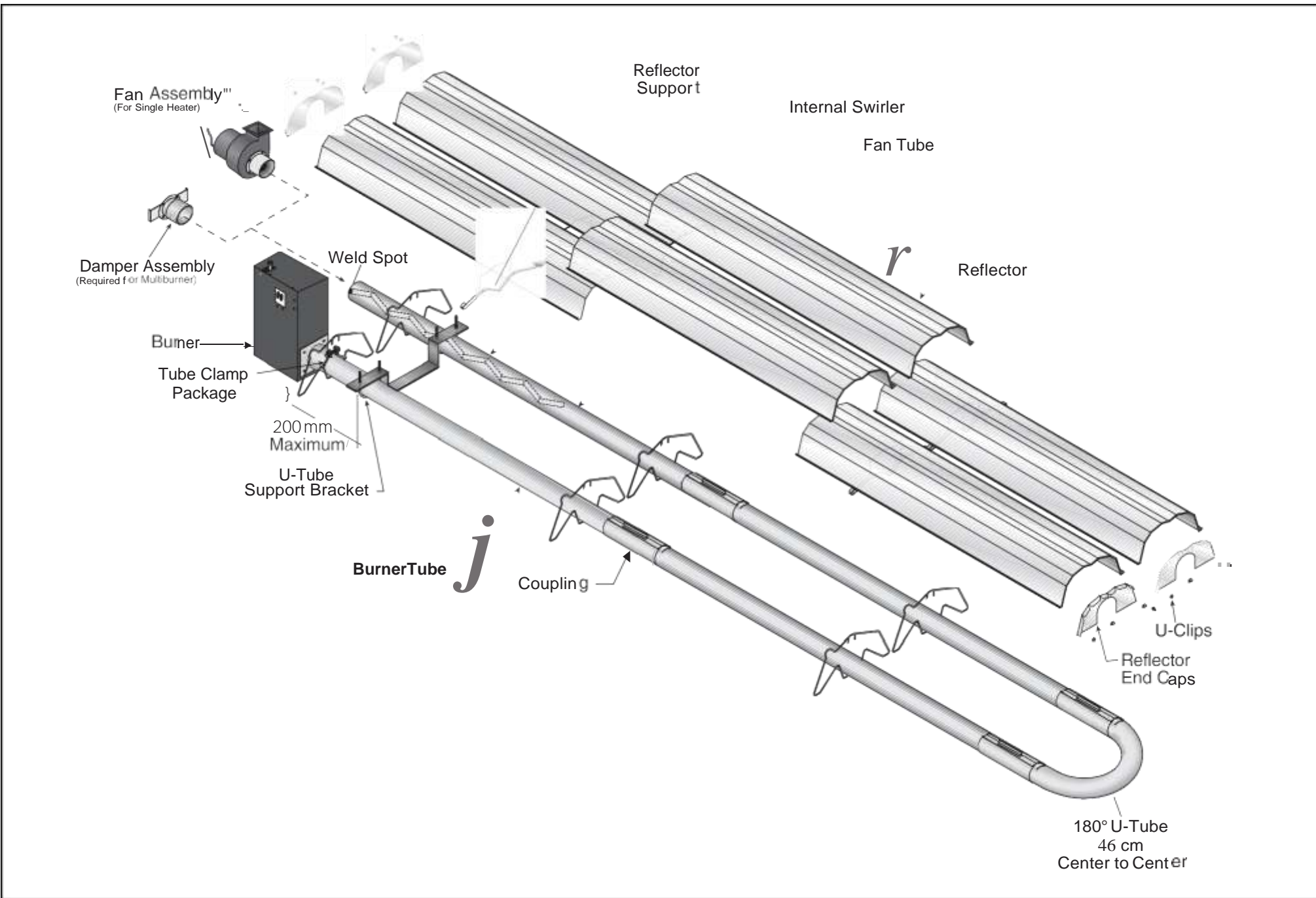
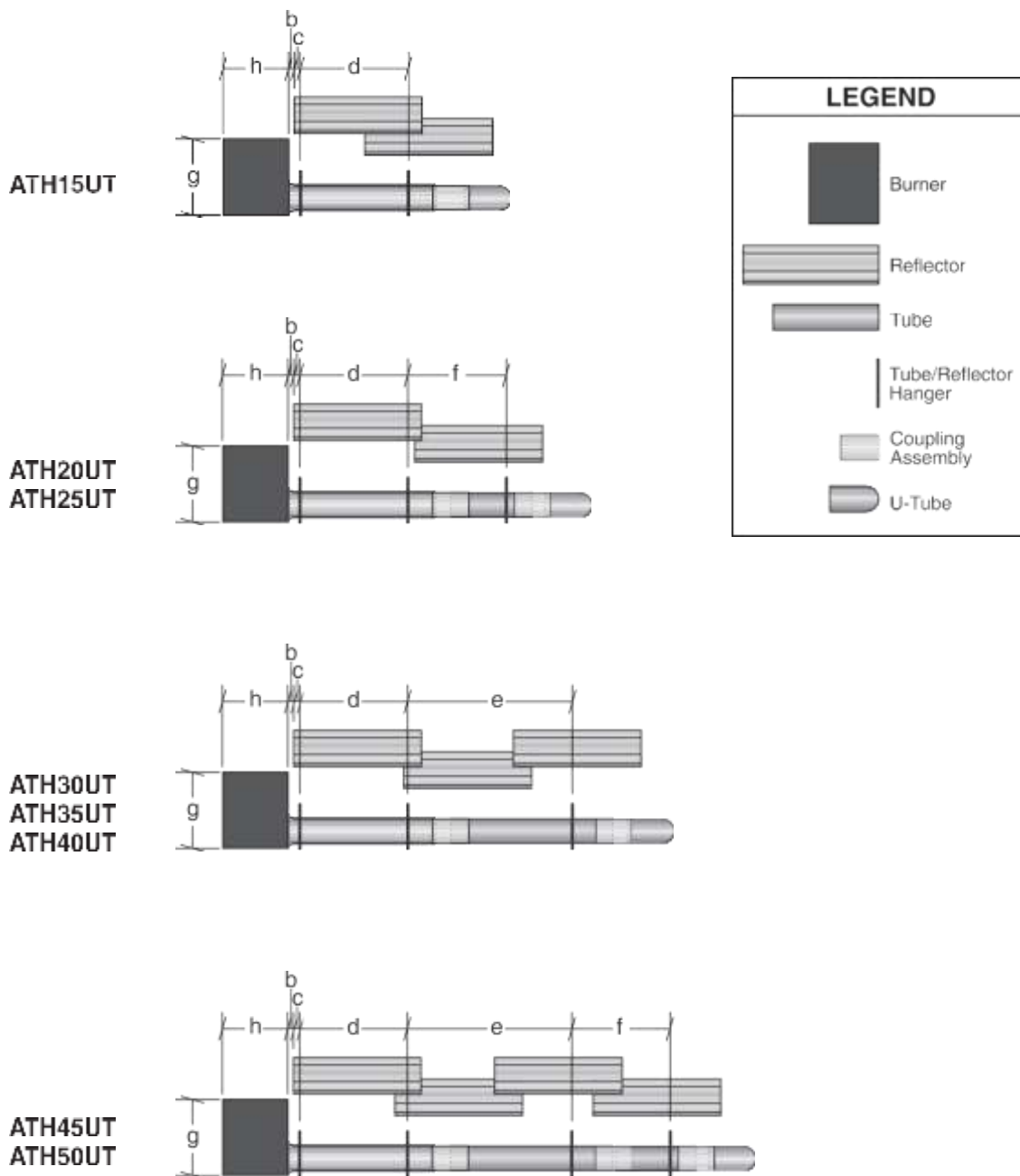

Figure 24: U-Tube Layout Overview



- a =
- b =
- c =
- d =
- e = distance typical between hangers - 3050 mm
- f = distance between last full tube hanger and half tube hanger - 1900 mm
- g = burner height - 366 mm
- h = burner length - 291 mm

Model	ATH15UT	ATH20UT	ATH25UT	ATH30UT	ATH35UT	ATH40UT	ATH45UT	ATH50UT
Reflector Overlap (approx.)	1780 mm	250 mm	250 mm	580 mm	580 mm	580 mm	690 mm	690 mm

**Step 7.2 U-Tube Hanger Placement**

**NOTE:** Spreader bar must be used on single suspension point installations. Do not hang heater from spreader bar.

Description	Part Number
Bow Shackle	E0007576
Tube/Reflector Hanger	03090100
Spreader Bar	07260010

**Step 7.3 Burner Tube and Fan Tube Installation**

Offset mounting hole must be to the top.

Weld seam must be to the bottom of the tube.

Description	Part Number
Burner Tube	03051100
Fan Tube	S5127W

**Step 7.3.1 Tube Clamp Package Installation**

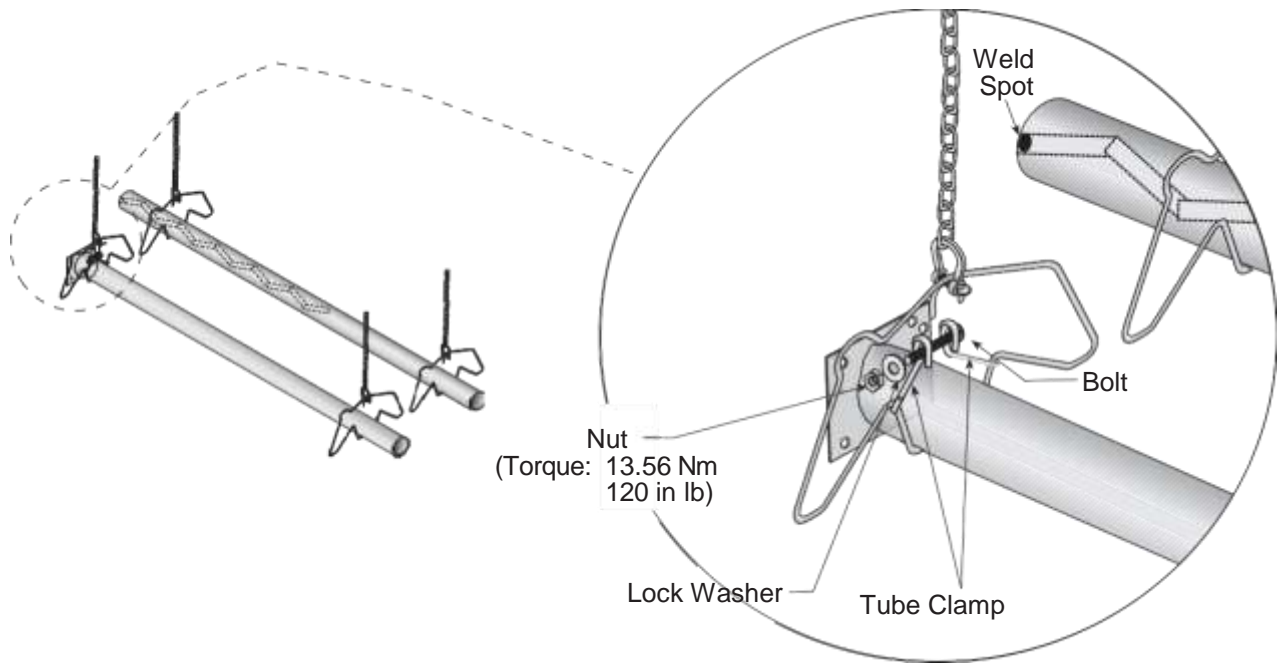

**Note:** Tube clamp package should be installed 100 mm from burner tube plate. Other hangers do not need tube clamp packages.

Description	Part Number
<b>Tube Clamp Package</b>	<b>01318901</b>
Tube Clamp	01396801
Bolt	97113940
Flat Washer	95211600
Nut	92113900

**Step 7.4 U-Tube Support Bracket Assembly Installation**

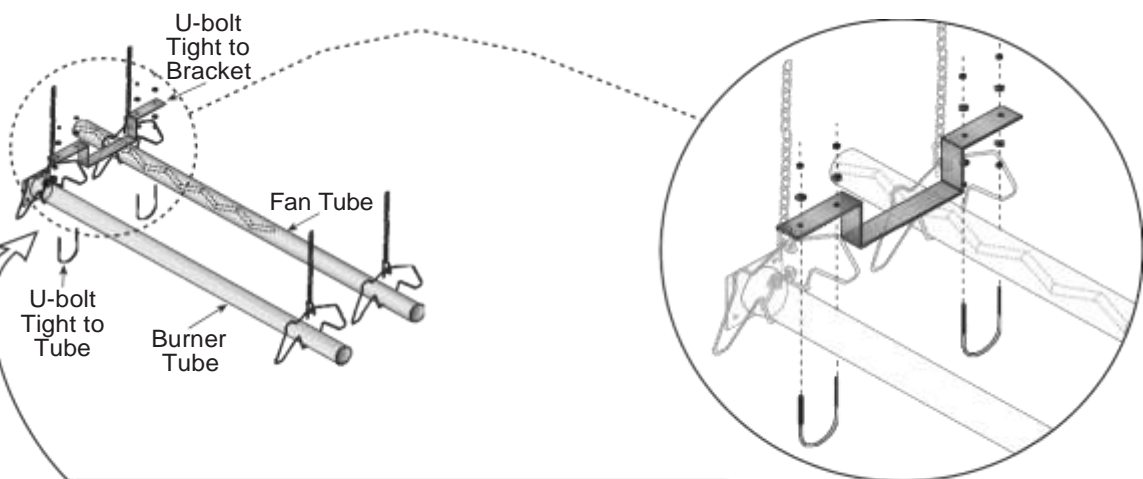

U-tube, Standard		U-tube, Opposite 45°	
<b>Tight U-bolt</b> 100 mm u-bolt, secured to burner tube with M6 lockwashers and M6 nuts. TIGHT.	<b>Loose U-bolt</b> 100 mm u-bolt, secured to bracket with M6 lockwashers and M6 nuts on top and bottom to allow for tube expansion and contraction.	<b>Tight U-bolt</b> 100 mm u-bolt, secured to burner tube with M6 lockwashers and M6 nuts. TIGHT.	<b>Loose U-bolt</b> 100 mm u-bolt, secured to bracket with M6 lockwashers and M6 nuts on top and bottom to allow for tube expansion and contraction.

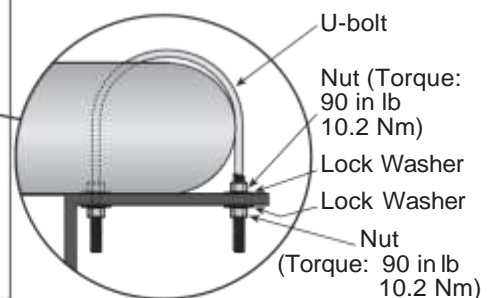



**Step 7.5 Coupling and Tube Assembly**

**A** Close coupling with tab.

Open

Closed

**B** Start slide bar/coupling lock onto coupling.

Slide Bar

Wide End Coupling

76 mm to 101 mm

**C** Insert tubes into coupling.

Tube

Tube

Orient coupling so that the impact block is in the 2:00 or 10:00 o'clock positions

**D** Tighten coupling to join tubes.

Slide Bar

Coupling

Tube

Description	Part Number
Coupling	01329600
Slide Bar/Coupling Lock	01329700
Tube	91409408

**Step 7.5.1 Coupling and Tube Assembly (Continued)**

**Tighten slide bar as shown below.**

Drive slide bar until tight. End of slide bar should be within tolerance listed below.

± 50 mm

**Correct Slide Bar dimensions**

**Incorrect Slide Bar position**

• Repeat Step 7.5 A - D until all tubes are assembled.

## Step 7.6 Tube Installation

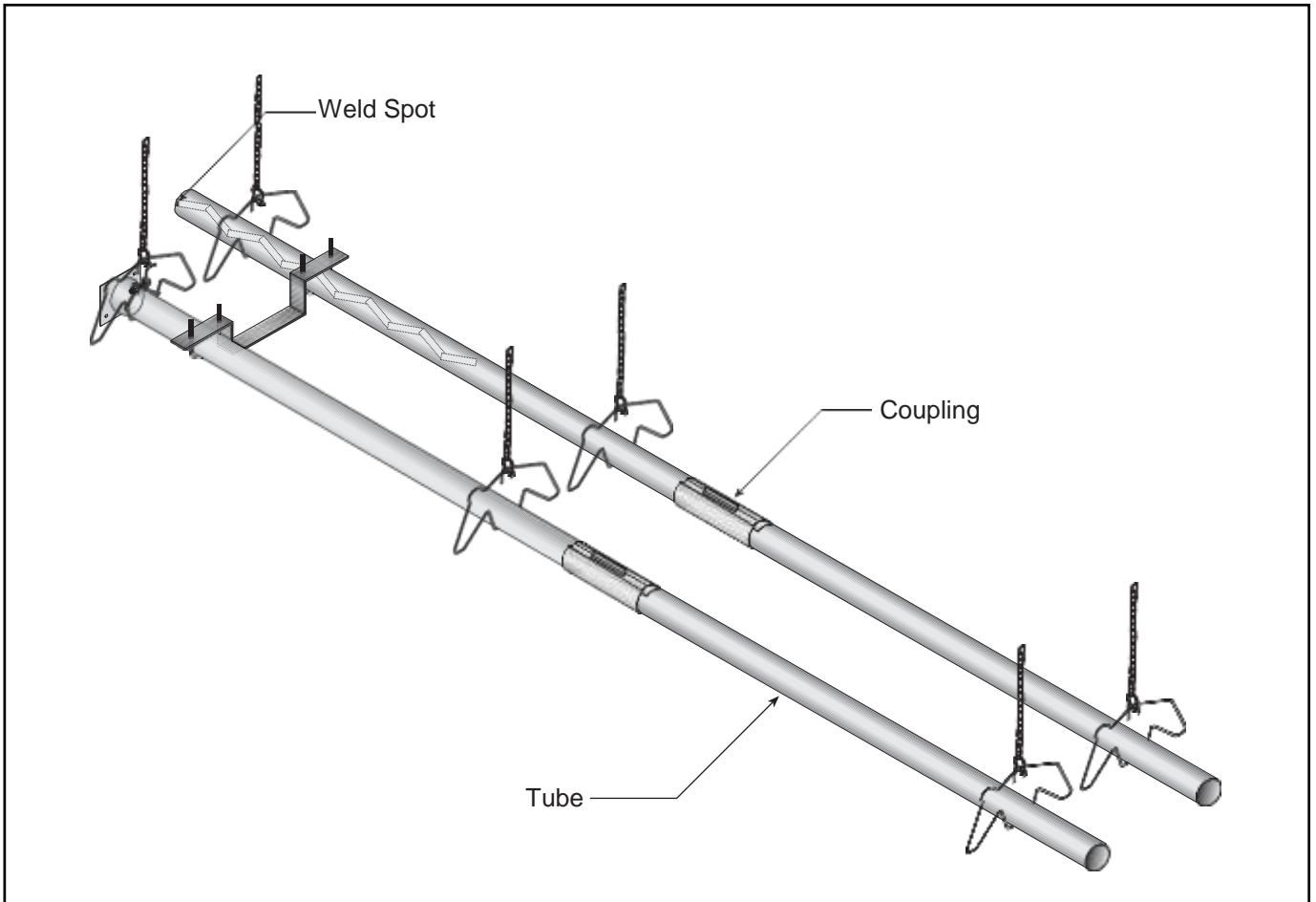

## Step 7.7 U-Tube Installation

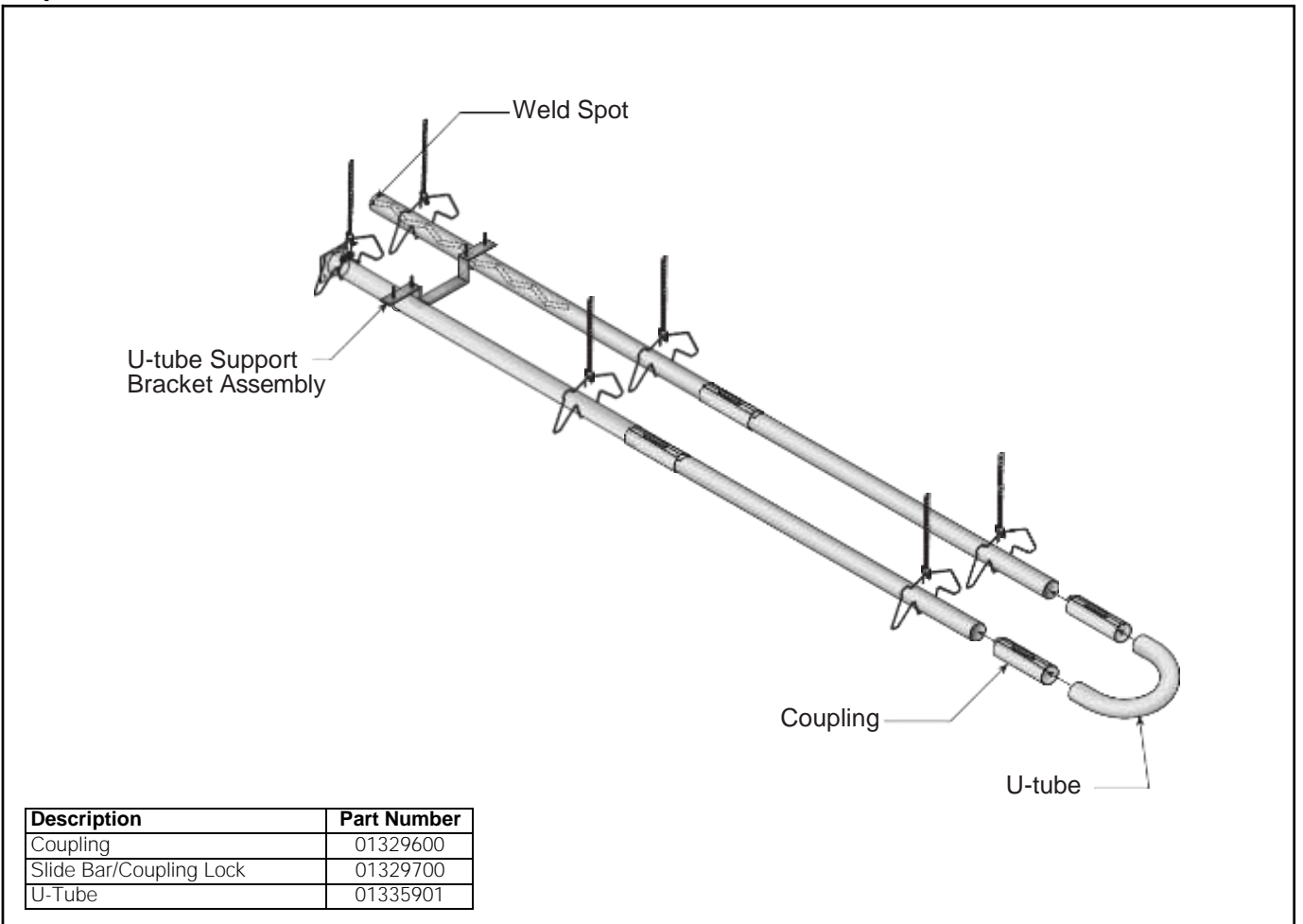

### Step 7.8 Reflector Installation

## **⚠ WARNING**



### **Fire Hazard**

**Support reflector with reflector hanger and support strap.**

**Reflector must not touch tube.**

**Failure to follow these instructions can result in death, injury or property damage.**

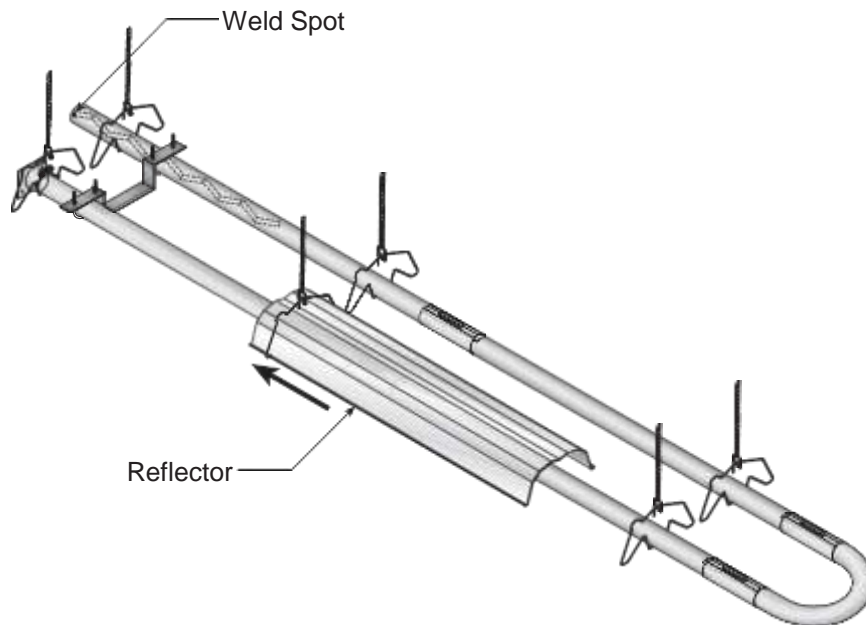

Description	Part Number
Reflector	02750303

### Step 7.8.1 Reflector, U-Clip and Reflector Support Installation

The pictorial drawings of the heater construction in **Section 6** are schematic only and provide a general guideline of where hangers, reflector supports and U-clips are to be installed.

To ensure proper expansion and contraction movement of the reflectors, a combination of U-clips and reflector

supports are used. The positioning of reflector supports and U-clips depend on the individual installation. Use either pop rivets or sheet metal screws instead of U-clips when installing end caps and joint pieces in areas where impact and high wind may be a factor. The following rules must be observed:

1. The first reflector after the burner must be affixed in the middle of the reflector with a reflector support and tight screws.

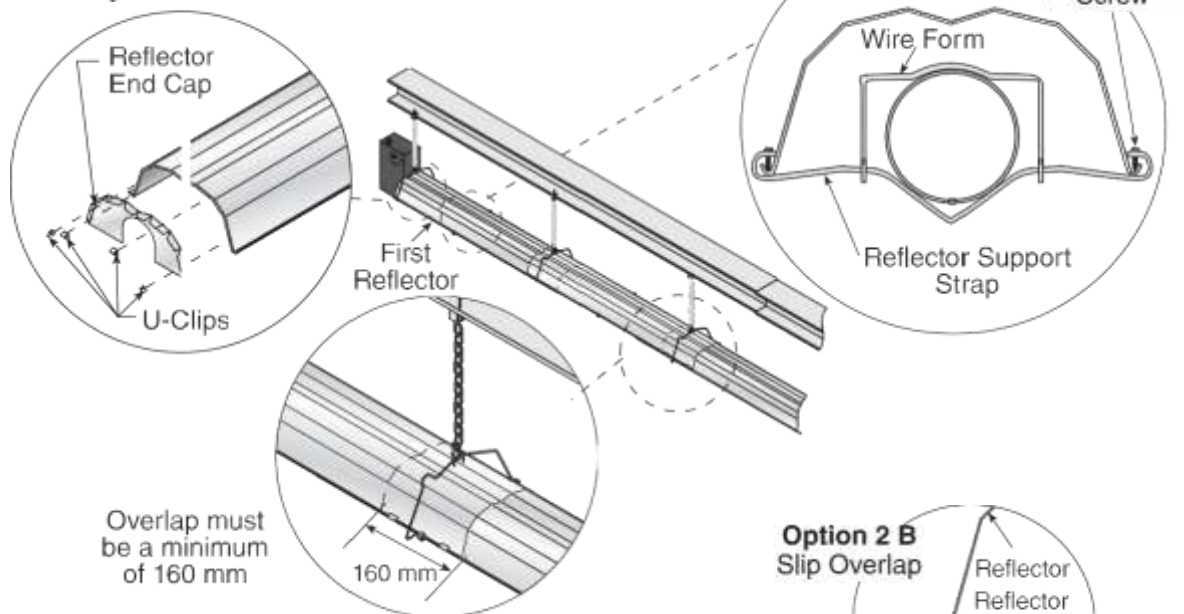

2 The overlap at the first and second reflector is a slip overlap. Thereafter, every third reflector joint is a slip overlap. A slip overlap is achieved by either:  
 a.) both reflectors lay inside a hanger. (no reflector support needed).  
 b.) using a reflector support with loose screws at the reflector overlap.

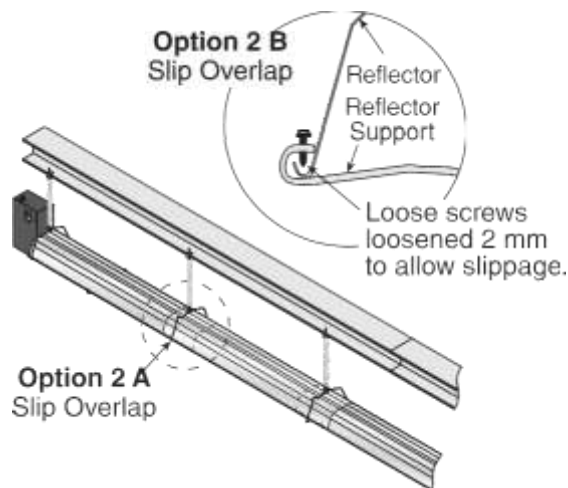

3 The remaining reflector overlaps require a non-slip overlap connection. To affix the reflectors together in a non-slip overlap either:  
 a.) use reflector support and tight screws.  
 b.) if both reflectors lay inside a hanger, u-clips or sheet metal screws may be used.

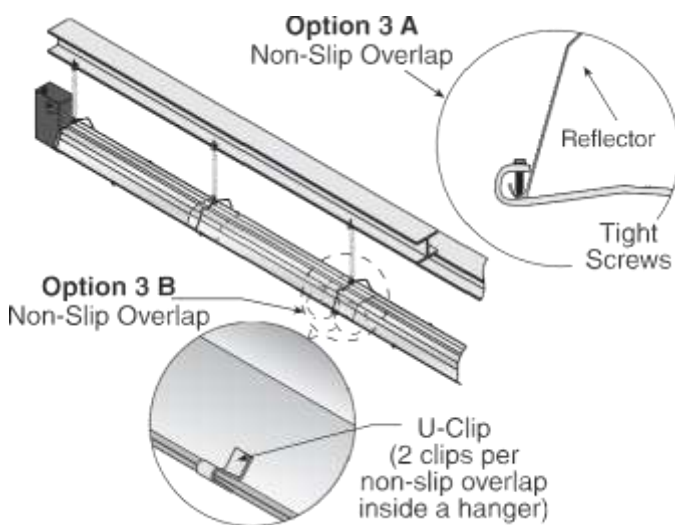

This section of three reflectors joined together must be affixed to the tube with at least one reflector support with tight screws.

Description	Part Number
<b>Reflector Support Package</b>	<b>03050010</b>
Wire Form	91908004
Reflector Support Strap	03050000
Screw #8 x 3/4 (3.9 x 19 mm)	94320812
U-Clip Package	91107720
Reflector End Cap	027508XX

**SECTION 8: MULTIBURNER CONFIGURATION & INSTALLATION**

**WARNING**



**Severe Injury Hazard**

**Secure burner to burner tube with bolts and lockwashers.**

**Hang heater with materials with a minimum working load of 75 lbs (33 kg).**

**Failure to follow these instructions can result in death, injury or property damage.**

**WARNING**



**Cut/Pinch Hazard**

**Wear protective gear during installation, operation and service.**

**Edges are sharp.**

**Failure to follow these instructions can result in injury.**

**8.1 Initial Assembly**

See Page 13, Section 6 for linear heater assembly instructions.

See Page 25, Section 7 for U-tube heater assembly instructions.

Check layout drawings for location of manifold pipe installation.

**Figure 25: Multiburner Damper Flange Installation**

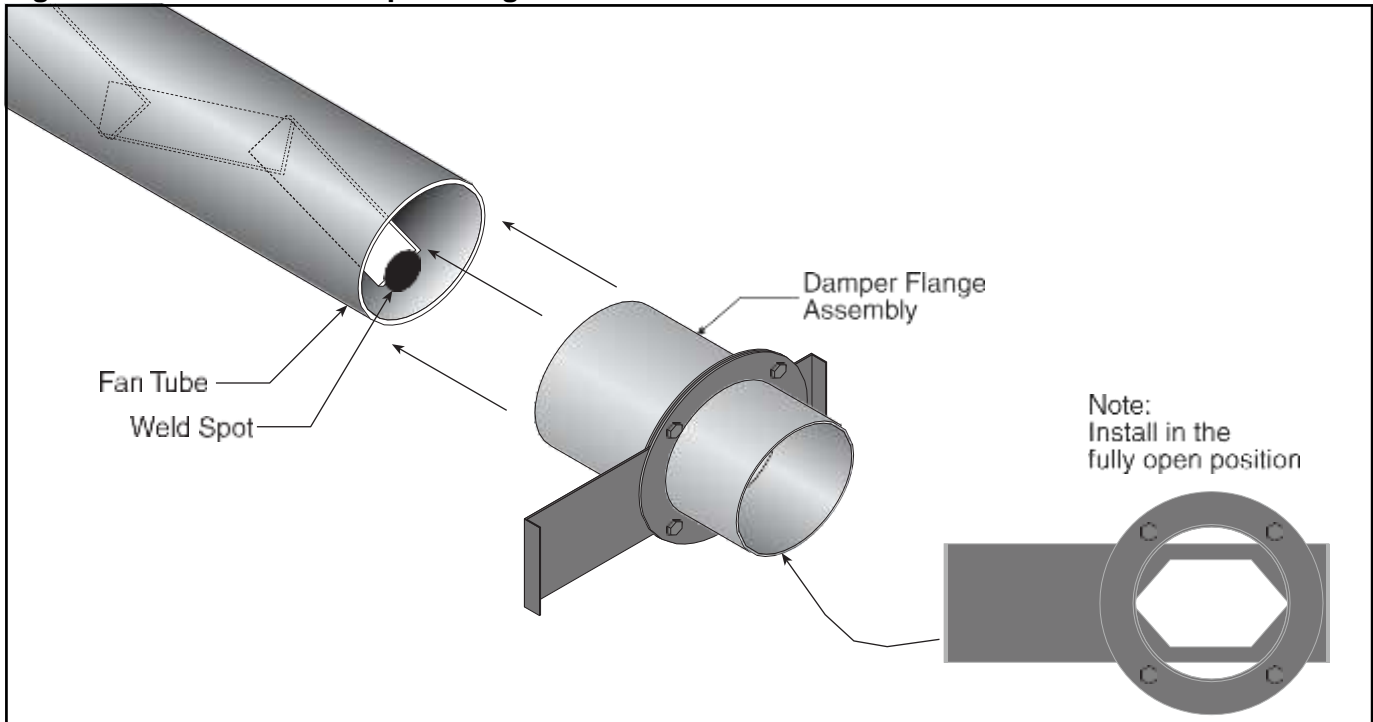
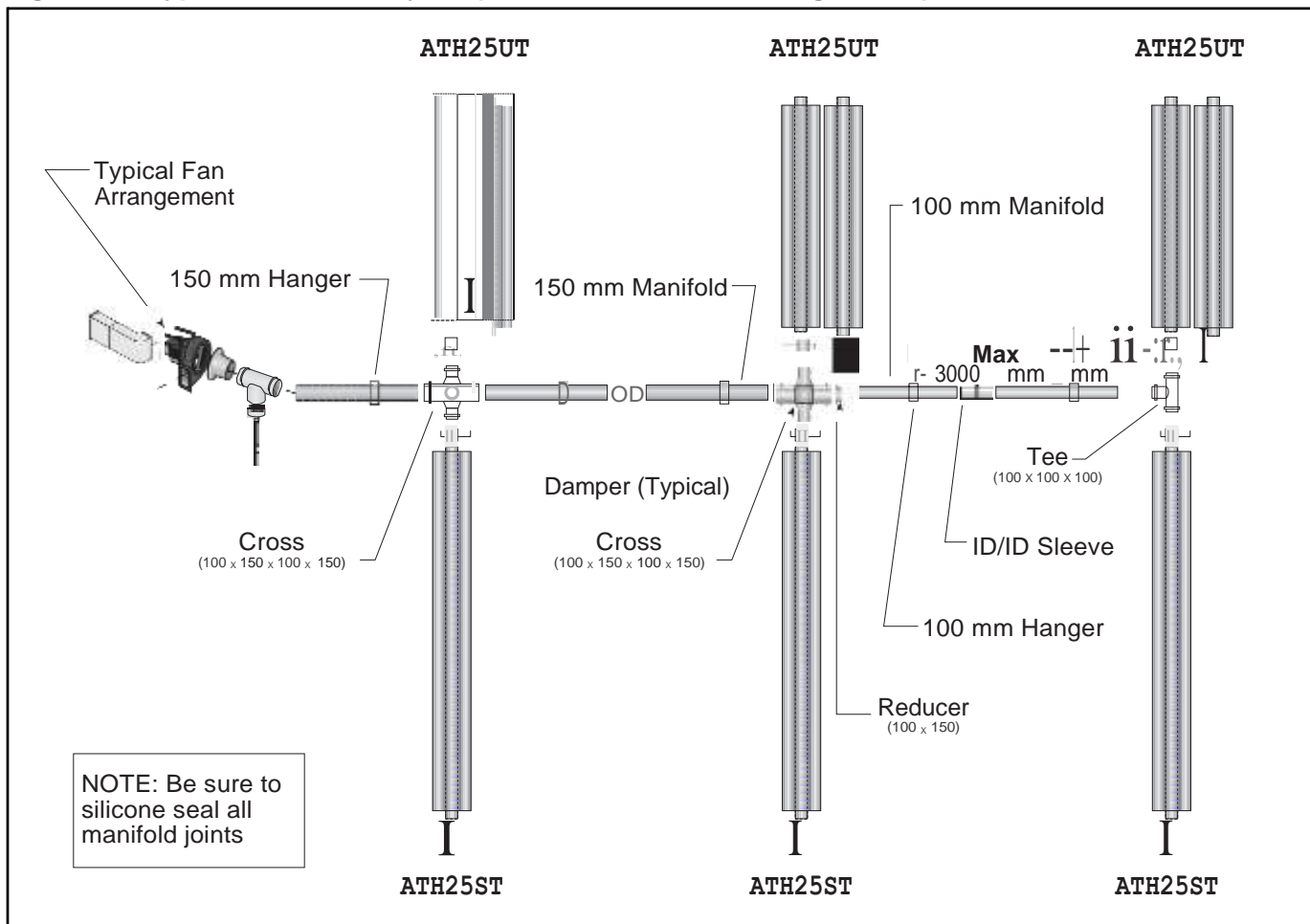
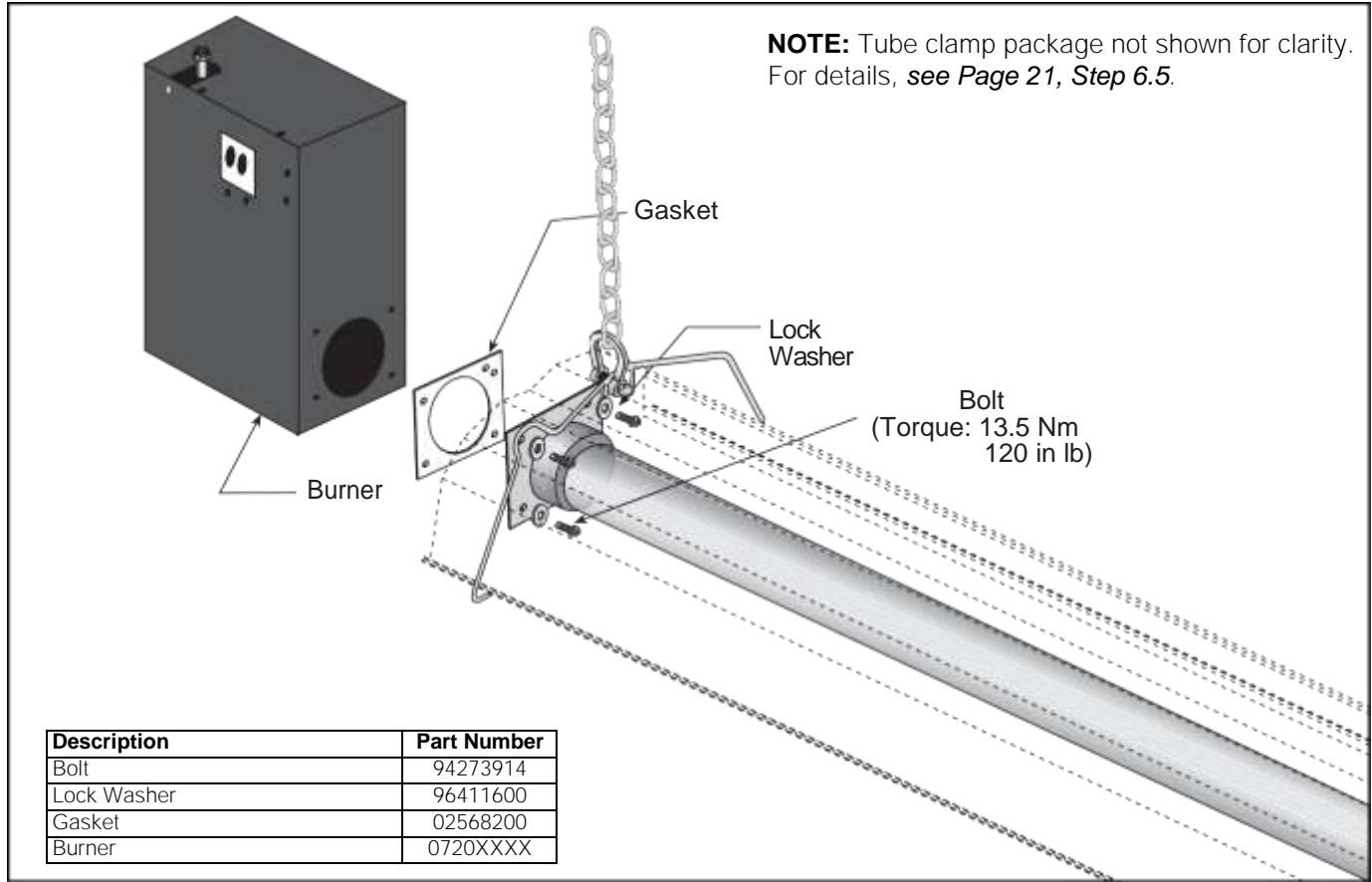

Figure 26: Typical Manifold Layout (Linear and U-Tube Configuration)



**SECTION 9: BURNER & FAN INSTALLATION**

**Step 9.1 Burner Installation**



**Step 9.2 Fan Assembly**

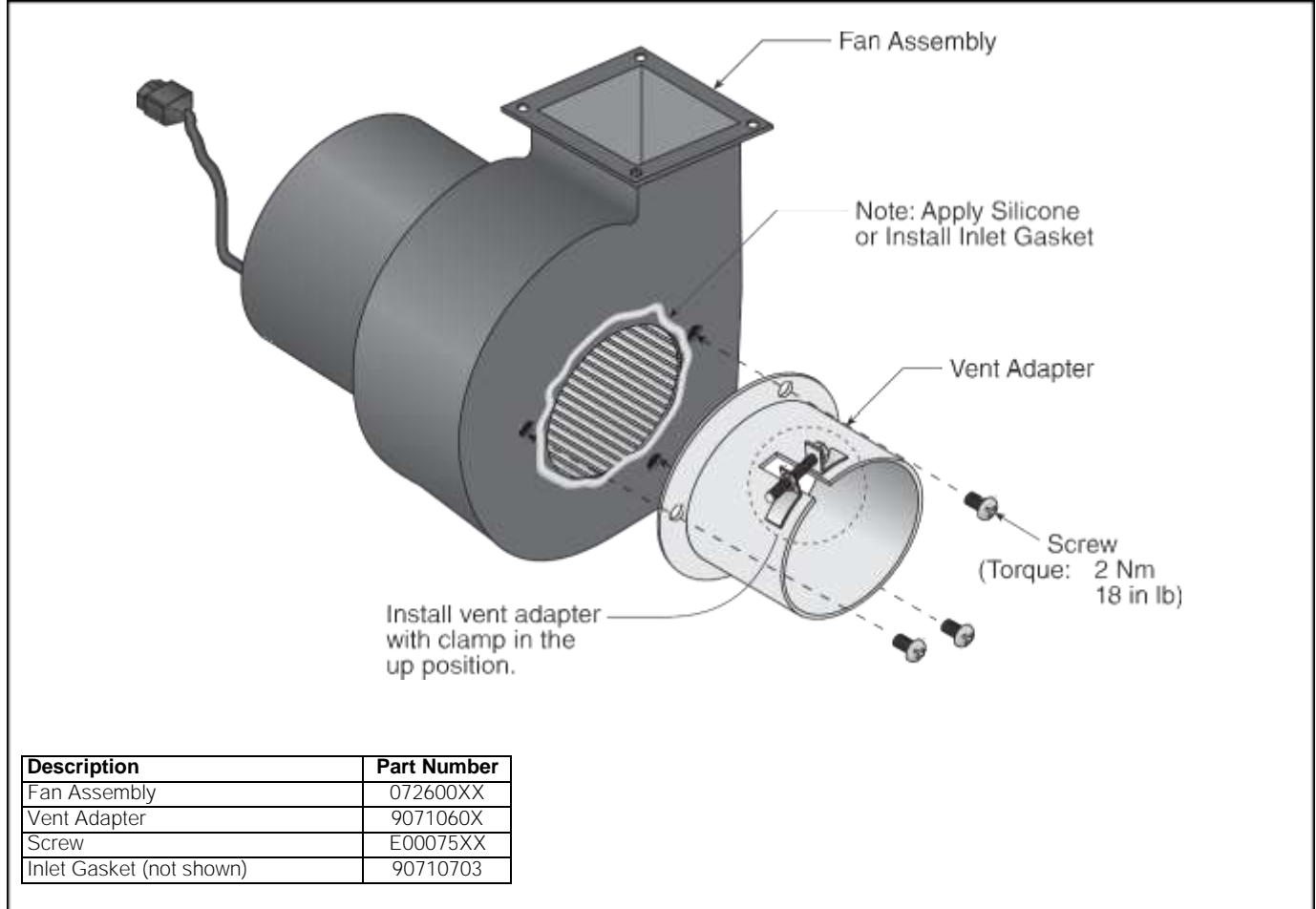

## 9.3 Linear &amp; U-Tube Fan Installation

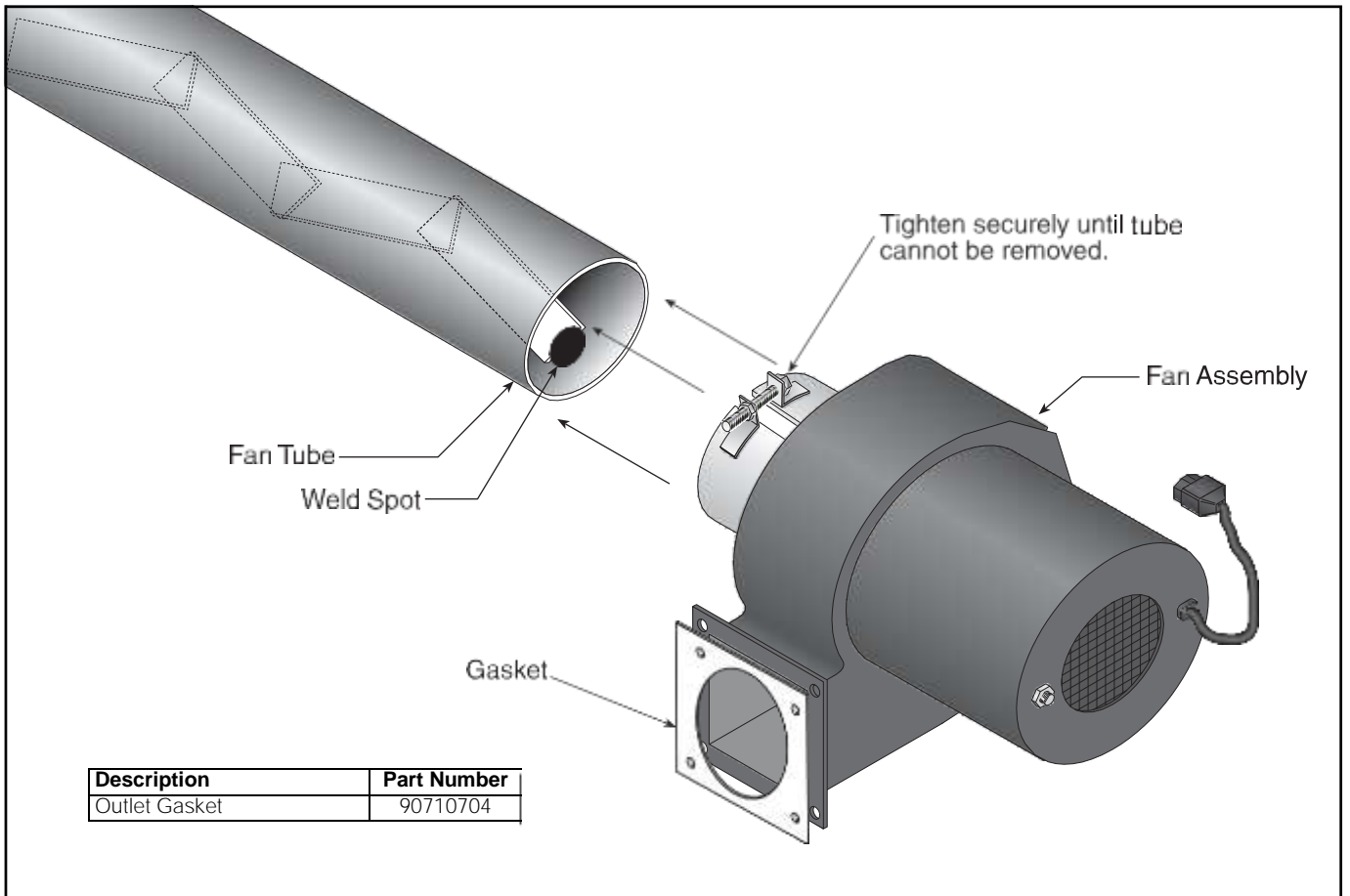

## Step 9.4 Double Linear Fan Installation

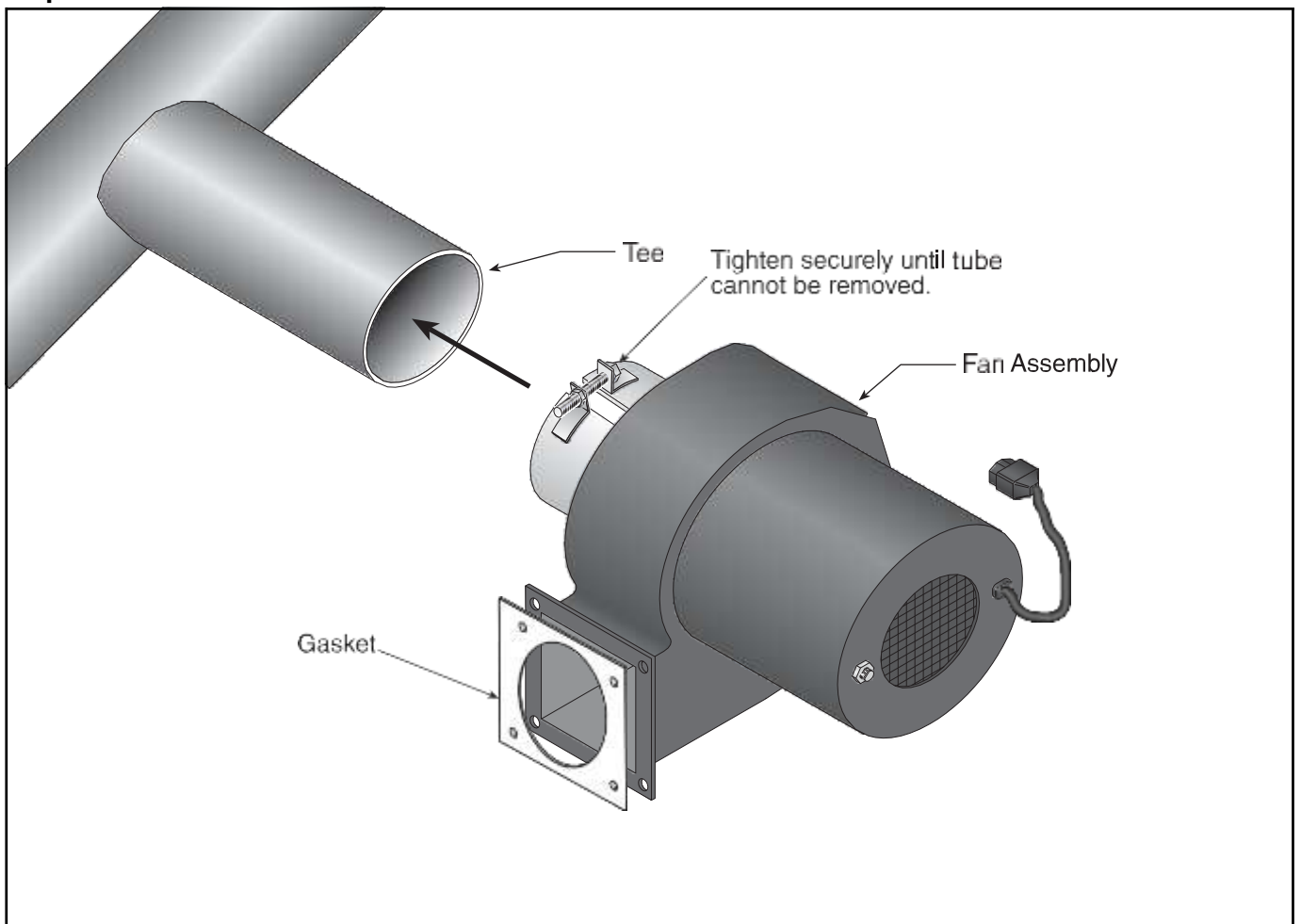



**Step 9.4.1 Double Linear Fan Installation (Continued)**

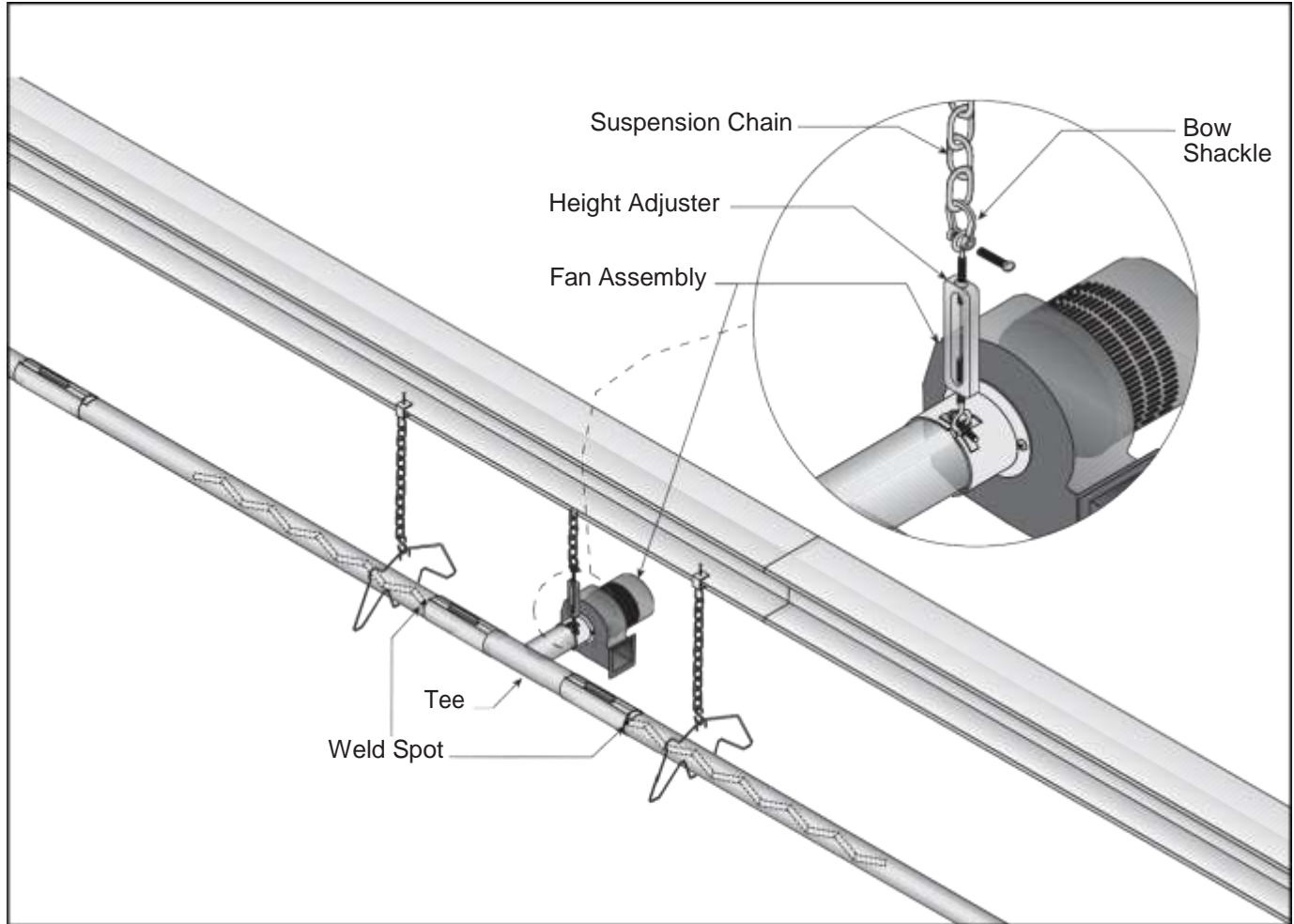

**Step 9.5 Multiburner 83 BWLG / 90 BWTL Fan Assembly (Horizontal and Vertical Outlets)**

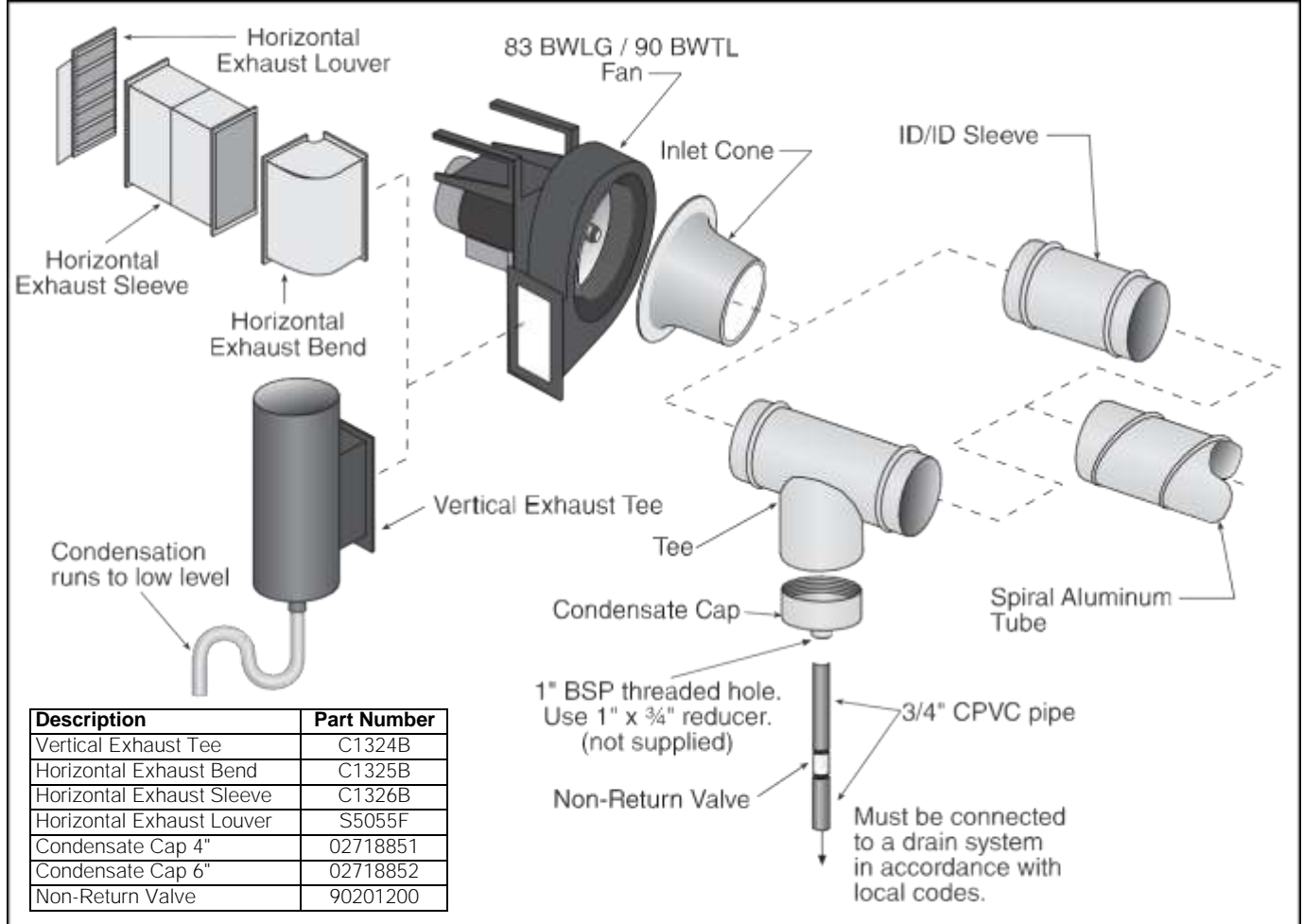

## Step 9.6 Condensate Drain Assembly

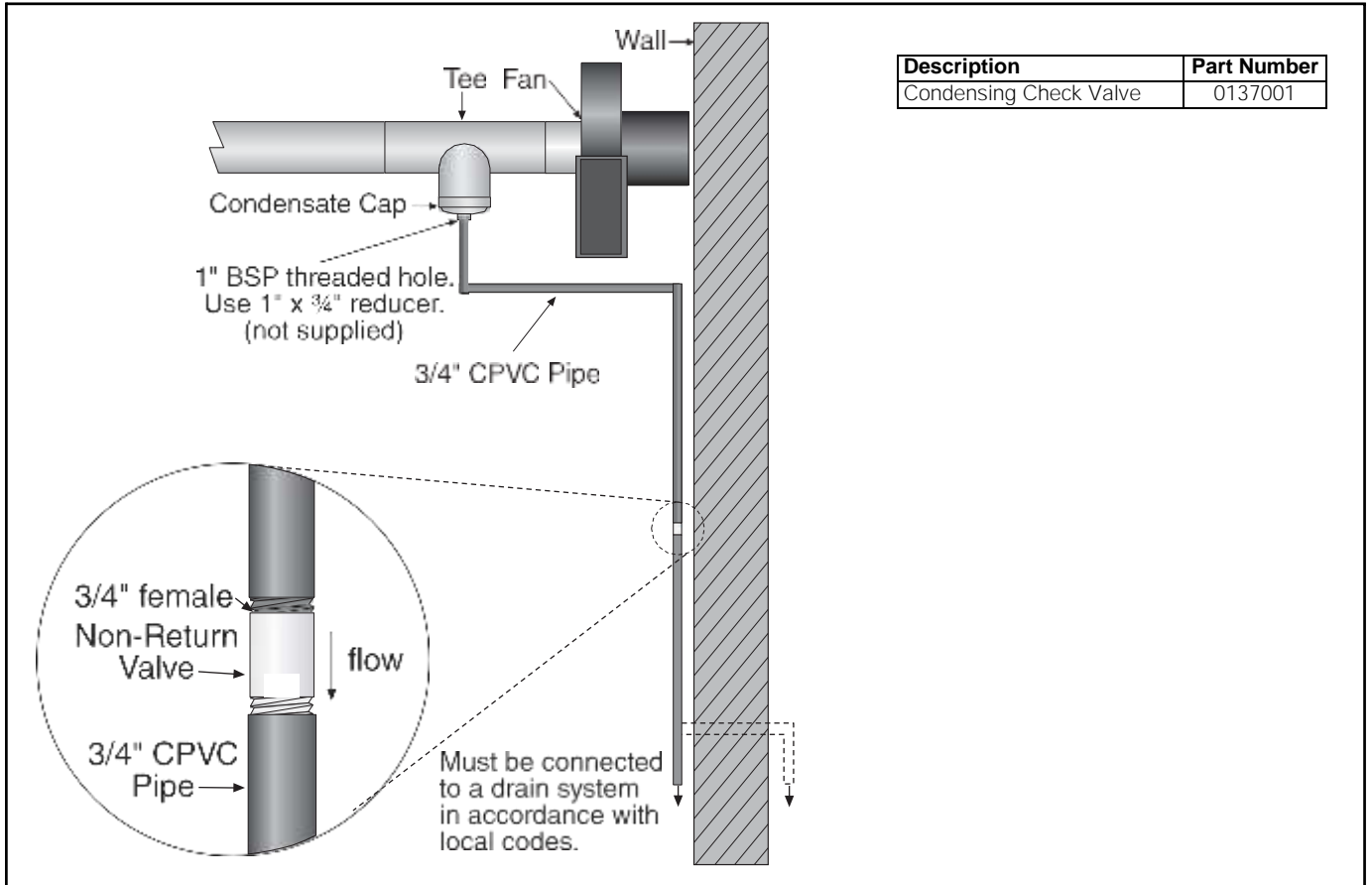

**SECTION 10: OPTIONAL HEATER ACCESSORIES**

**! WARNING**



**Cut/Pinch Hazard**

**Wear protective gear during installation, operation and service.**

**Edges are sharp.**

**Failure to follow these instructions can result in injury.**

10.1 Reflector Side Extension Installation

Step 10.1.1 Bracket Installation

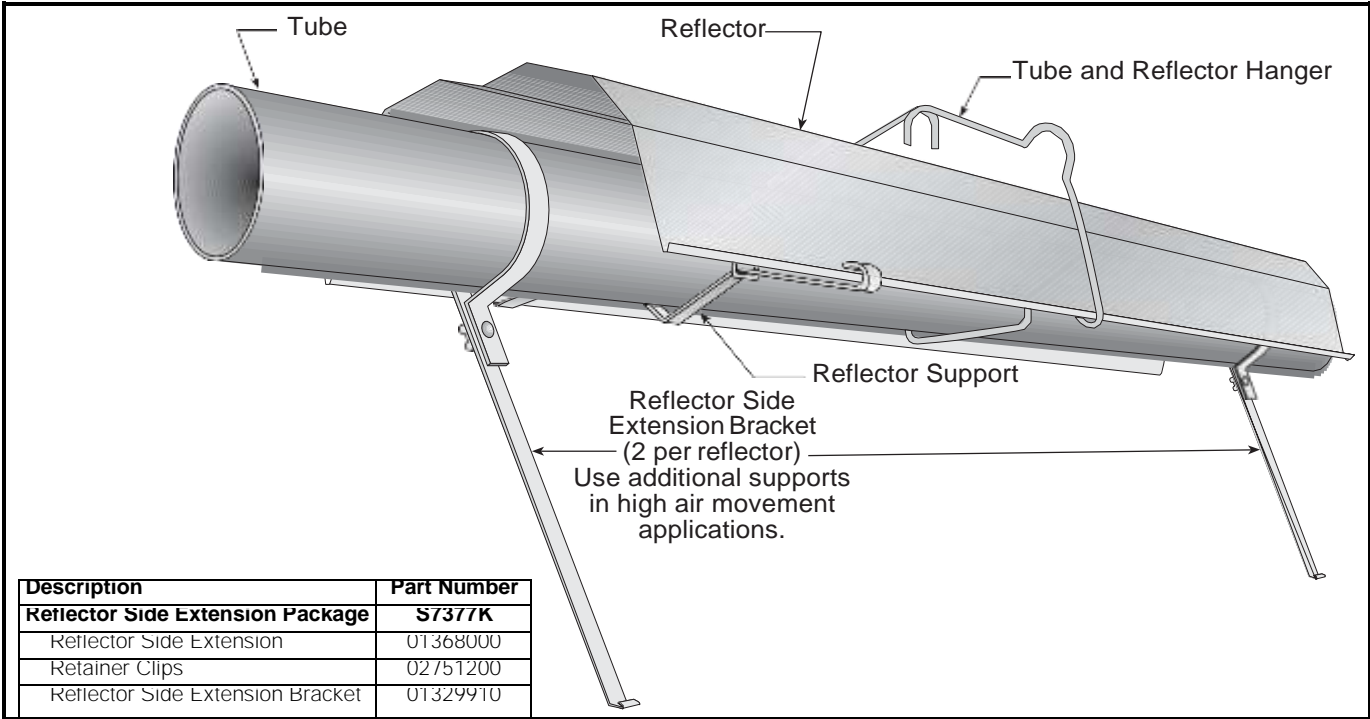

Step 10.1.2 Side Reflector Installation

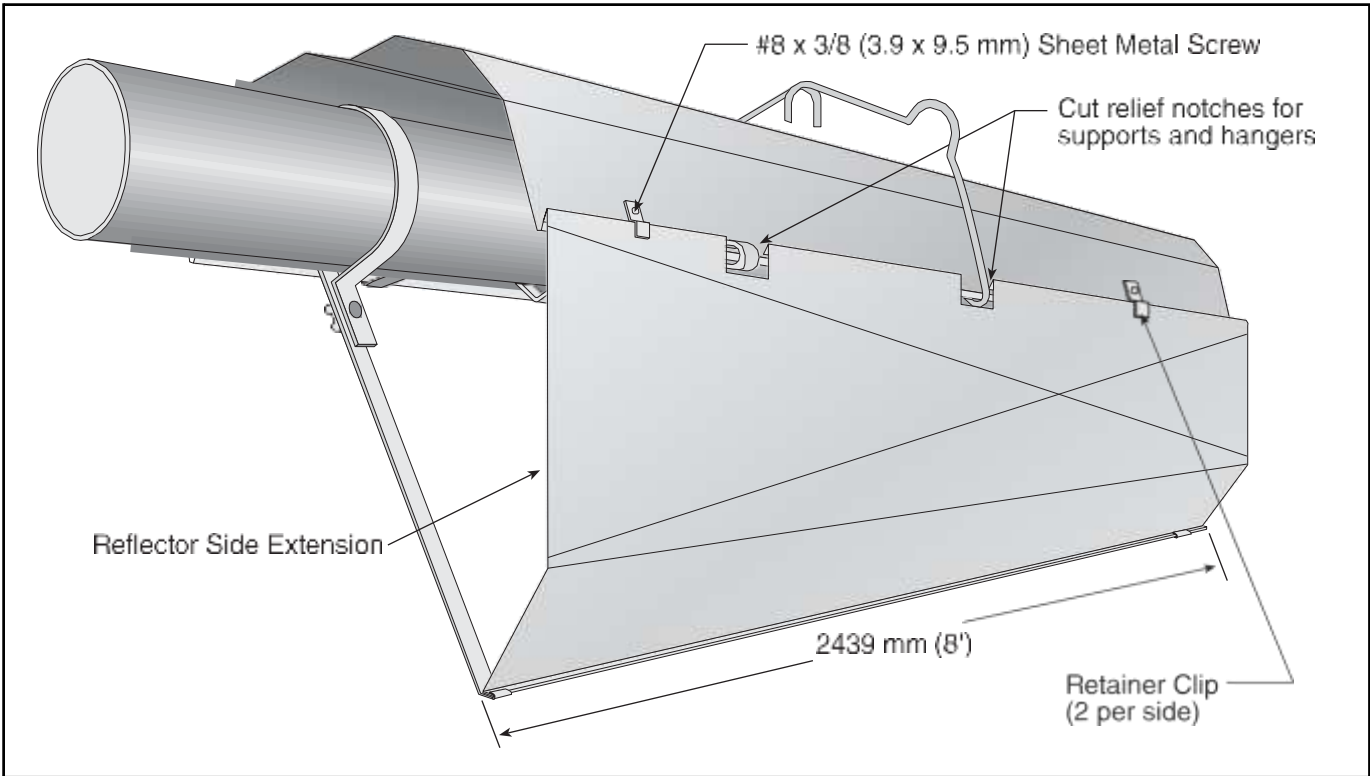

## 10.2 U-Tube Cover Installation

The package contains two reflector joint pieces (P/N 02750901), one 2439 mm (8') reflector and 18 x #8 sheet metal screws. Install the U-tube cover using the following procedure.

### Step 10.2.1

Cut the 2439 mm (8') reflector in half to be used on both sides to cover the U-tube.

### Step 10.2.2

Flatten 1220 mm (4') reflector edge where joint piece matches. Put a mark on the 1220 mm (4') reflector, directly over the tube center. Center the accessory joint piece on the mark and scribe its contour on the reflector. Scribe the location of the mounting holes.

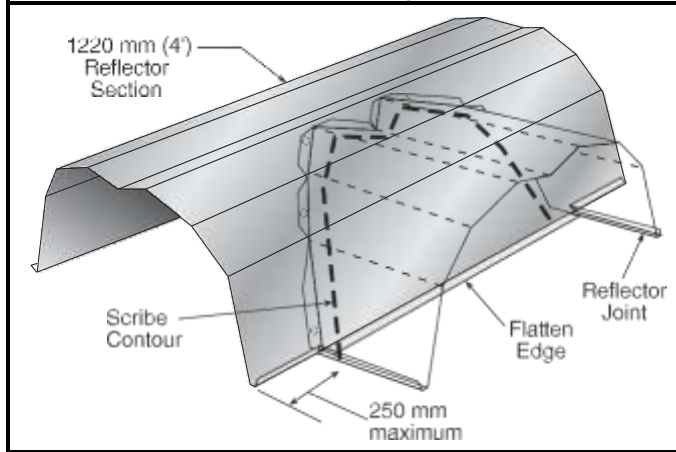

### Step 10.2.3

Cut away the reflector to clear the tube, leaving about 250 mm (1") of material inside the scribed contour to attach the accessory joint. Drill or punch six 3 mm diameter holes in reflector in the positions shown below.

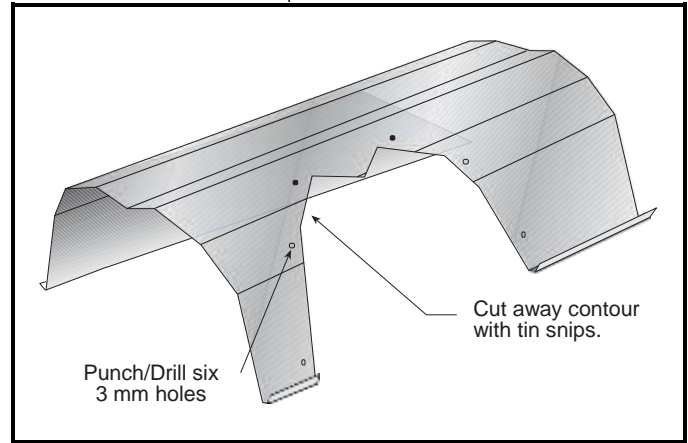

### Step 10.2.4

Use six #8 sheet metal screws to attach the joint piece.

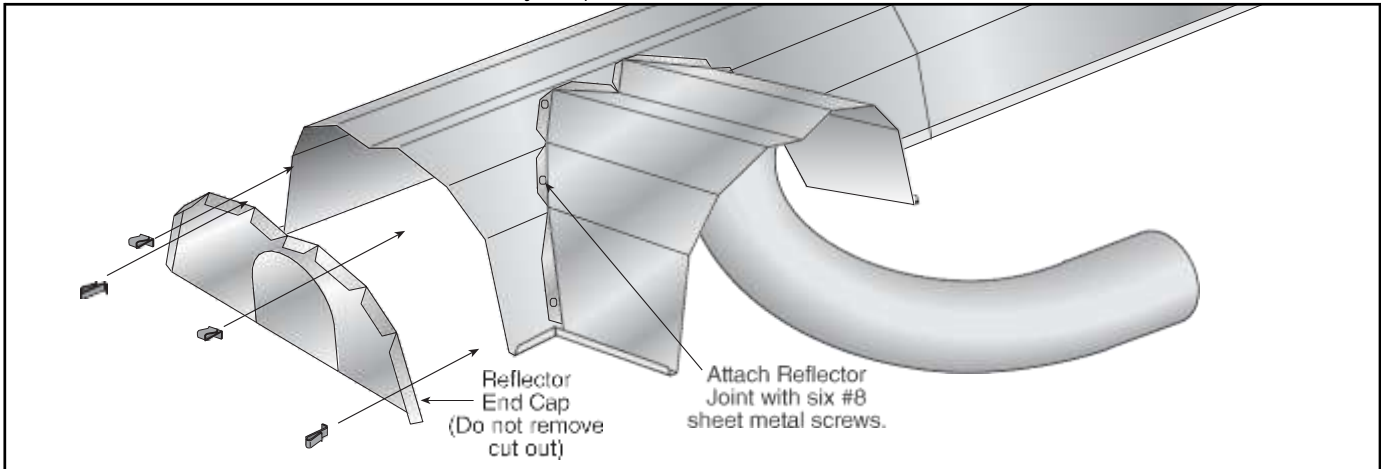

Repeat *Step 10.2.1 through Step 10.2.4* to attach the reflector joint piece on the other reflector.

### Step 10.2.5

The overlap of both reflector joint pieces is attached with six #8 sheet metal screws.

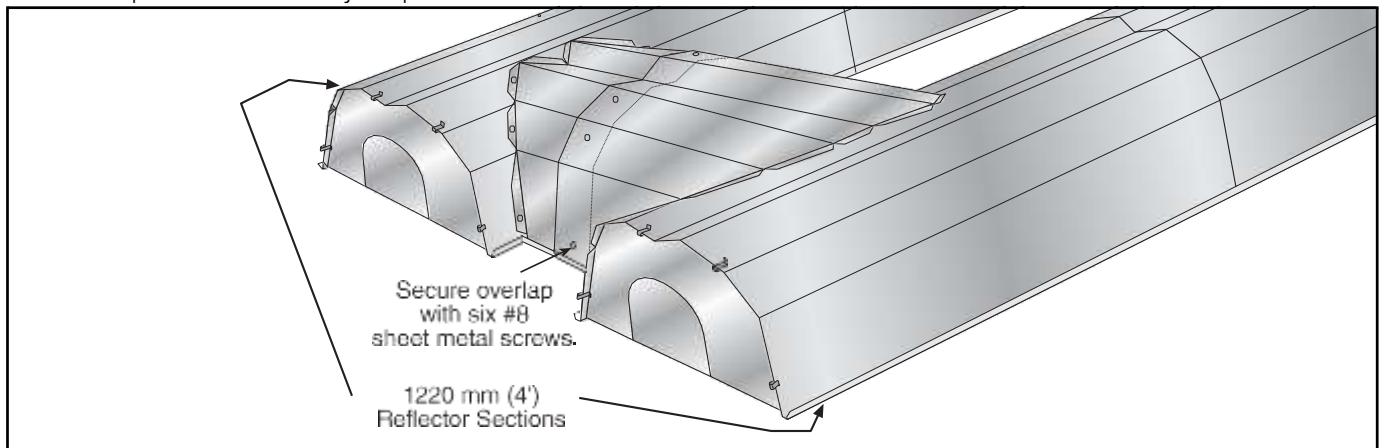

10.3 Decorative Grille Installation

Step 10.3.1 Grille Installation

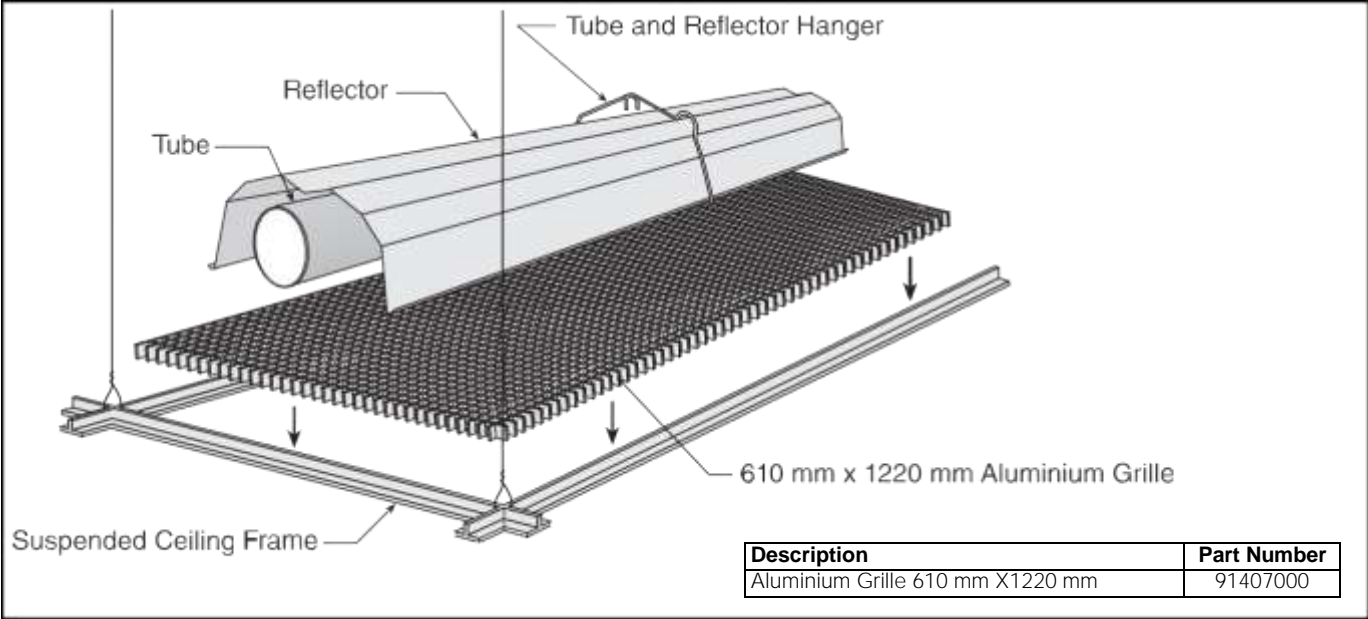

Step 10.3.2 Frame Shield Installation

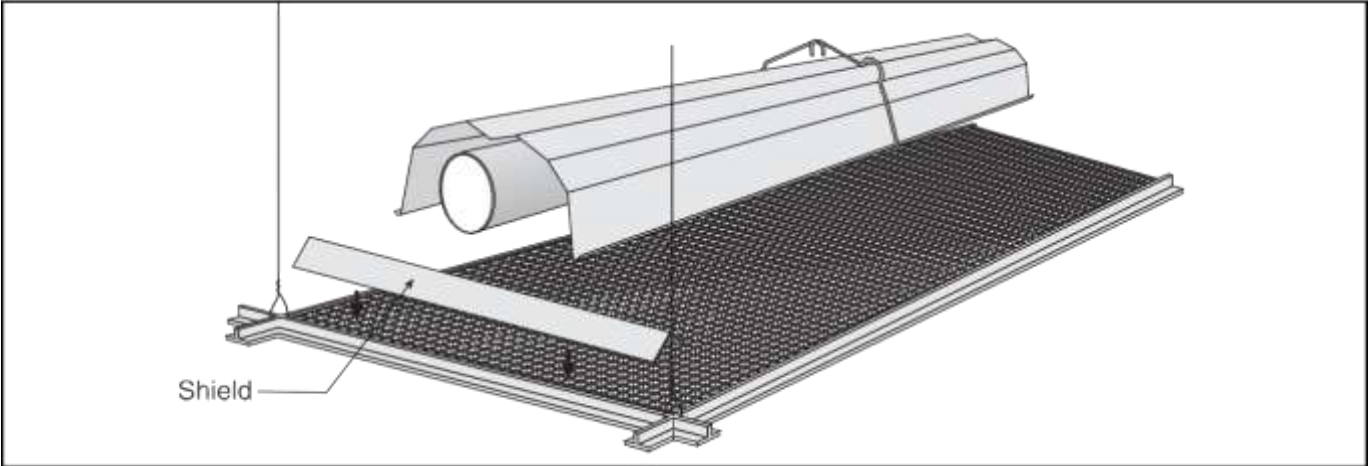

Step 10.3.3 Reflector Side Extension Installation for Decorative Grilles

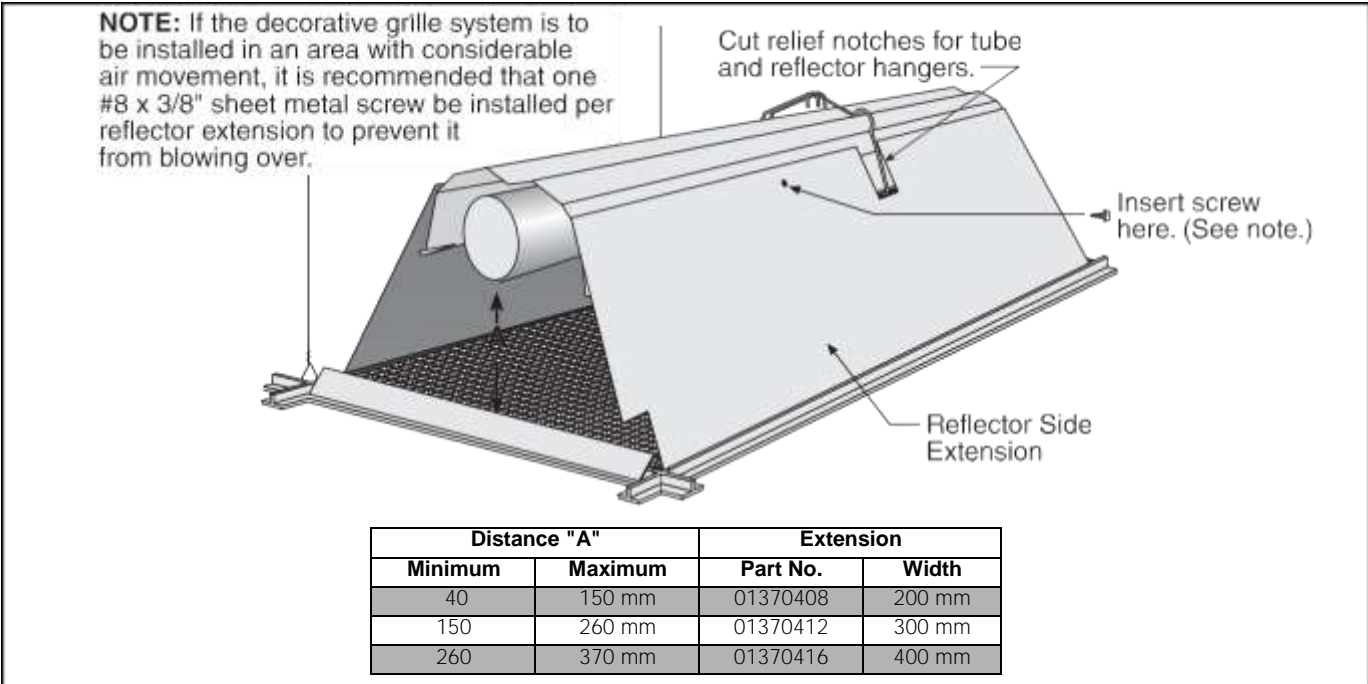

### 10.4 Protective Grille Installation

#### Step 10.4.1 Silicone Cap Installation

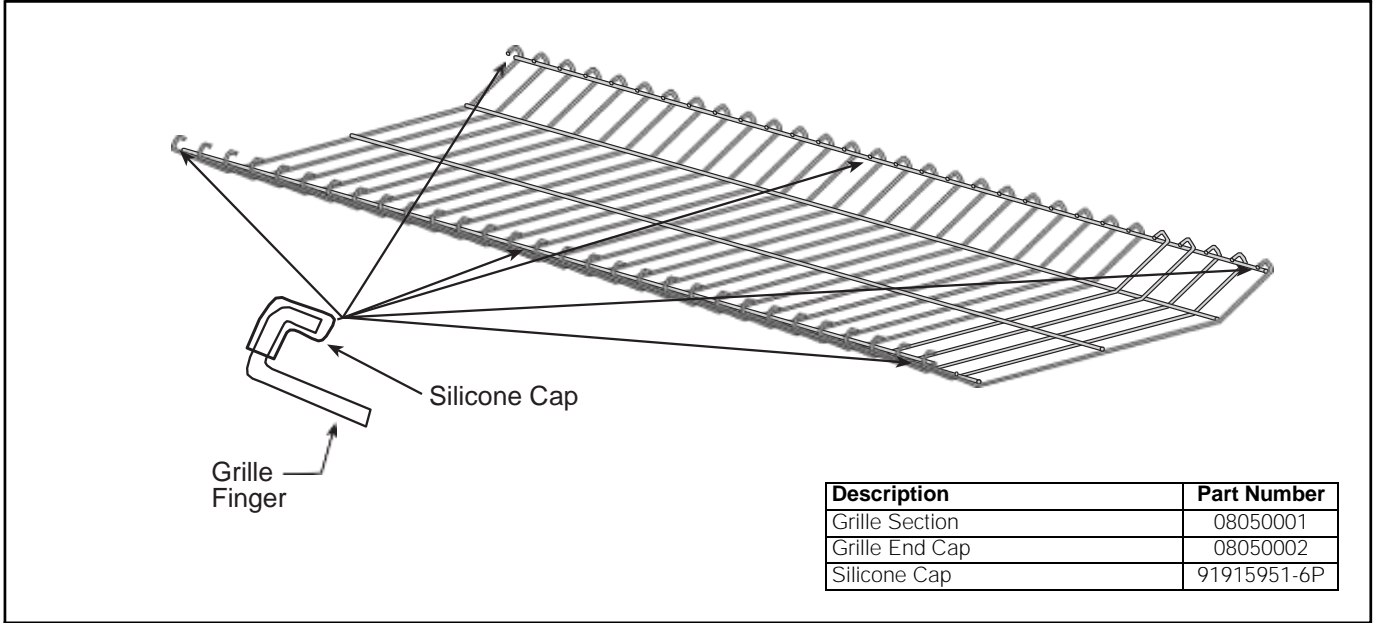

#### Step 10.4.2 Grille End Cap Installation

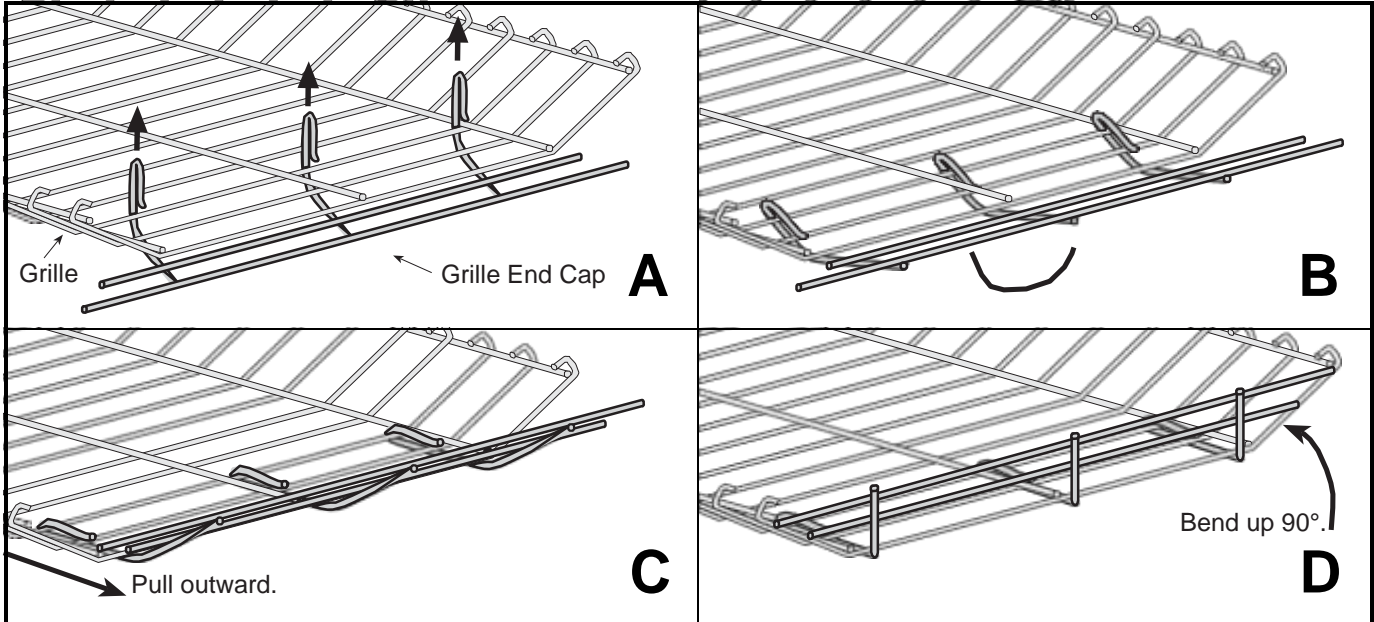

#### Step 10.4.3 Grille Installation

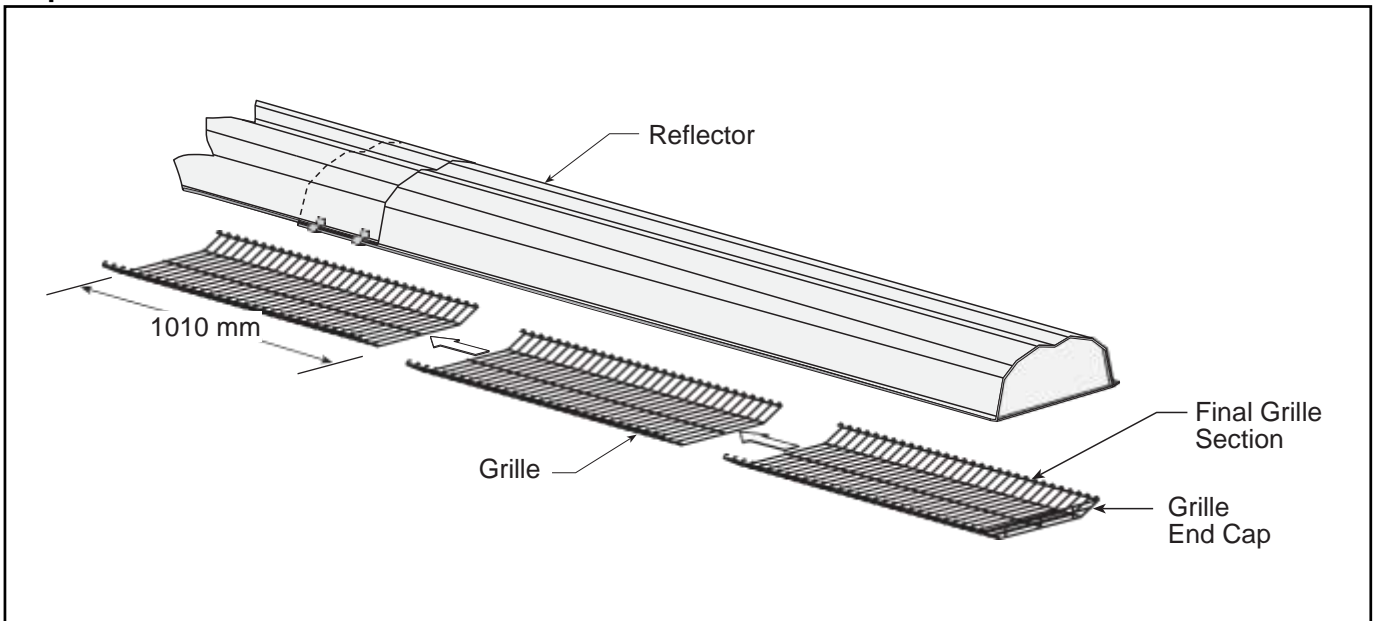

10.5 Sports Hall Guard Installation

Step 10.5.1 Grille Installation

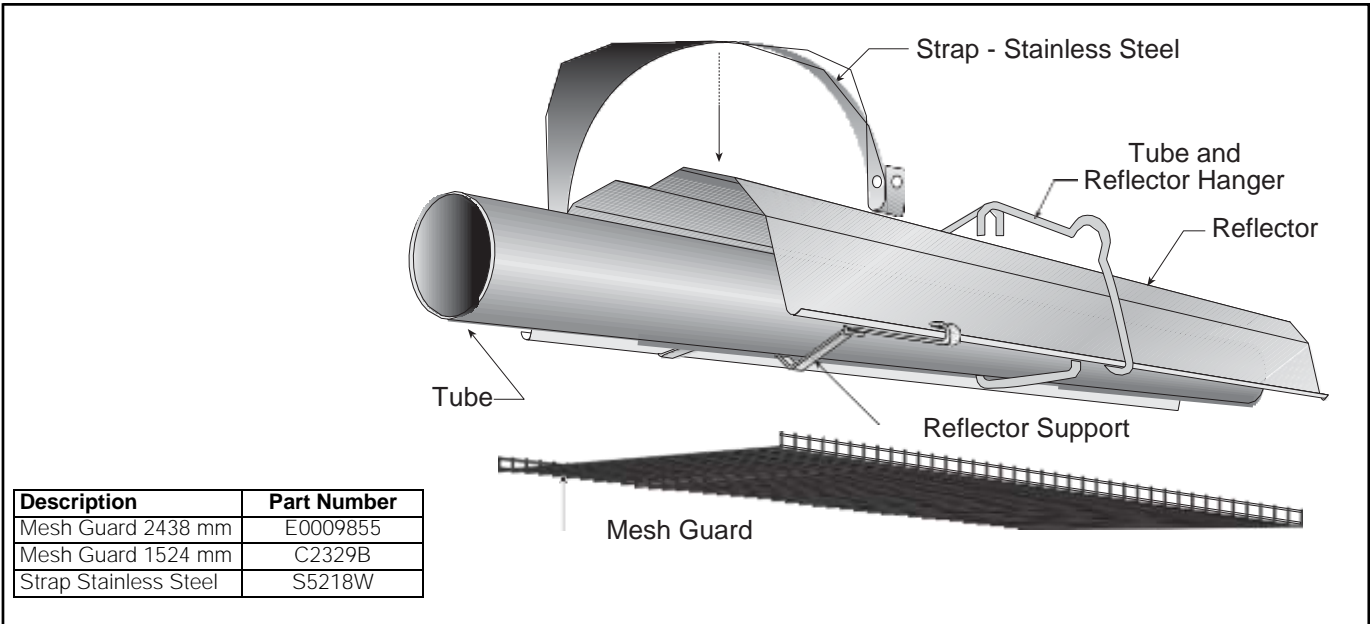

Step 10.5.2 Fastener Installation

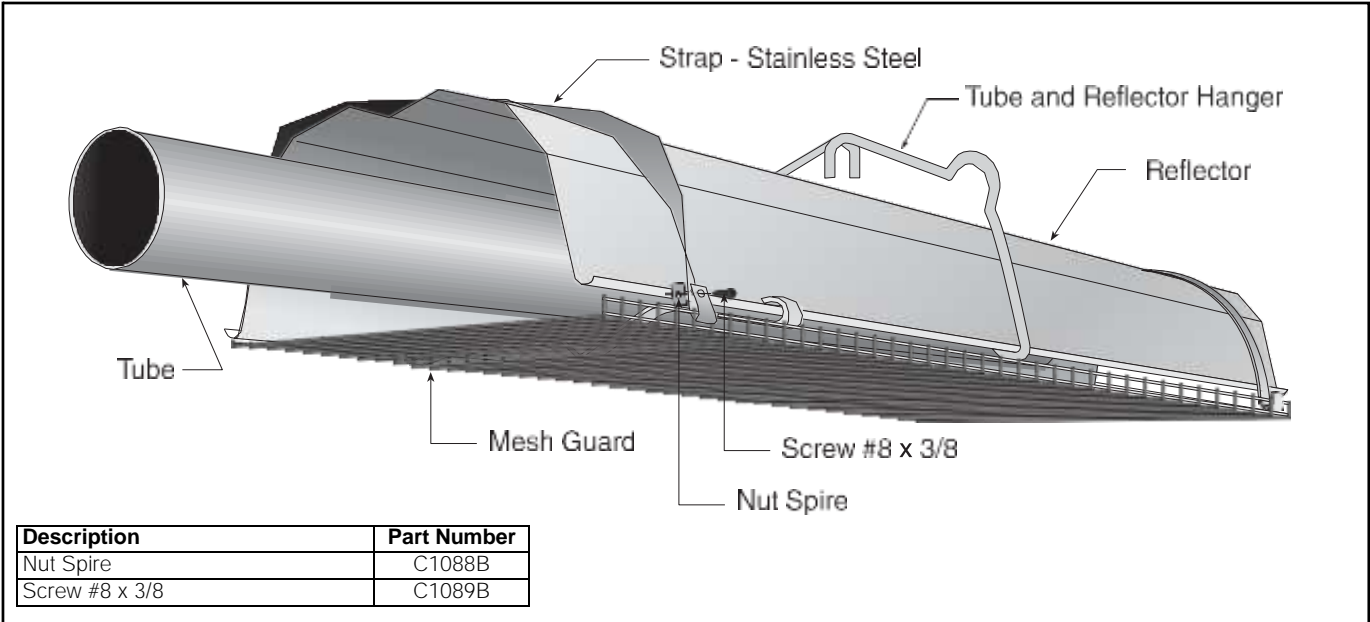

Step 10.5.3 Mesh Guard Connection

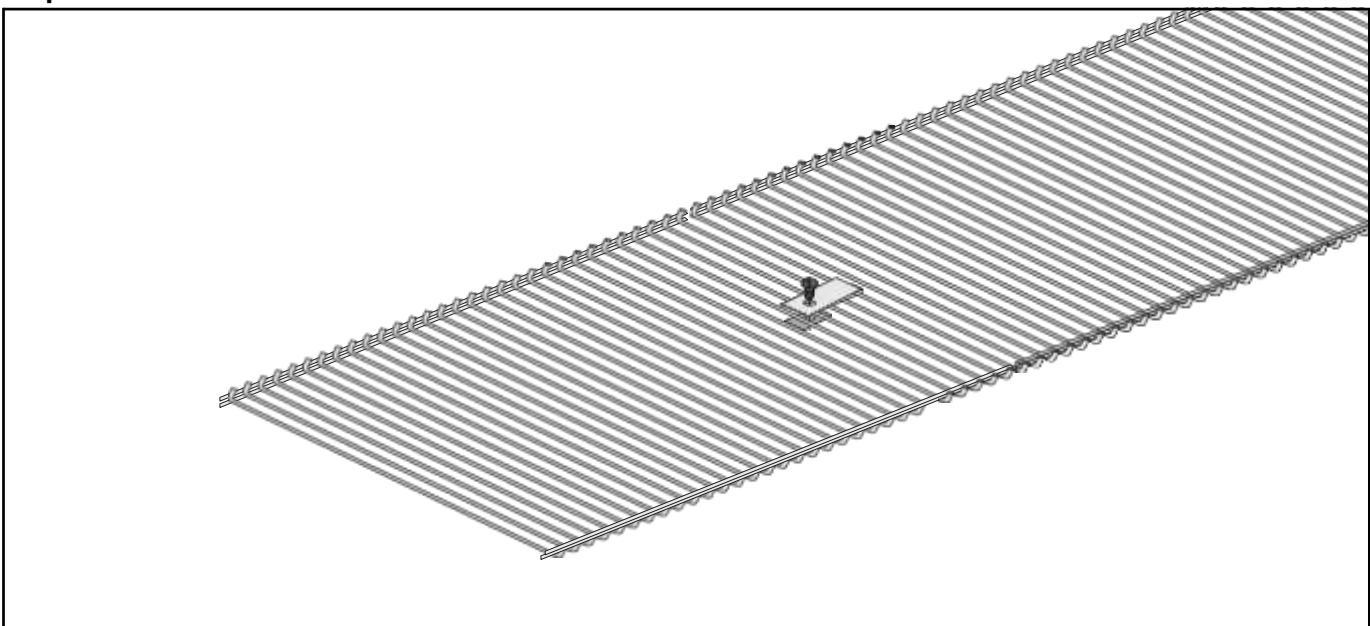



## 10.6 Undershield Installation

### 10.6.1 Hanger Installation

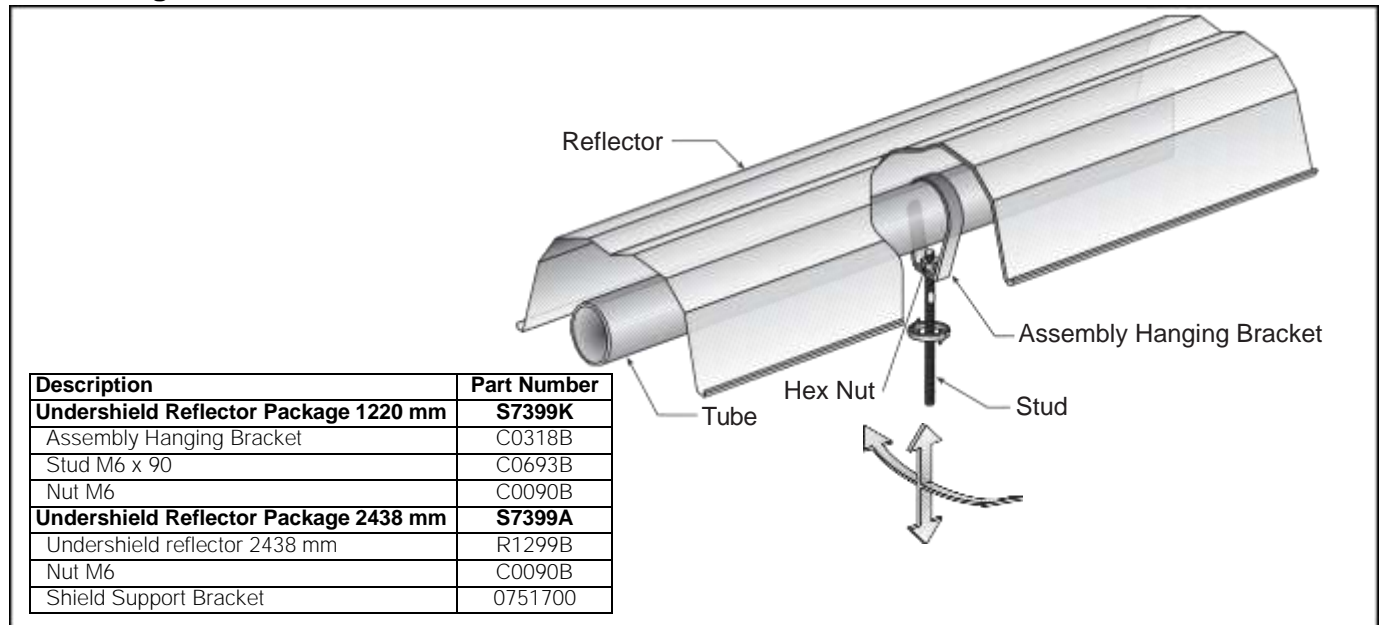

### 10.6.2 Undershield Installation

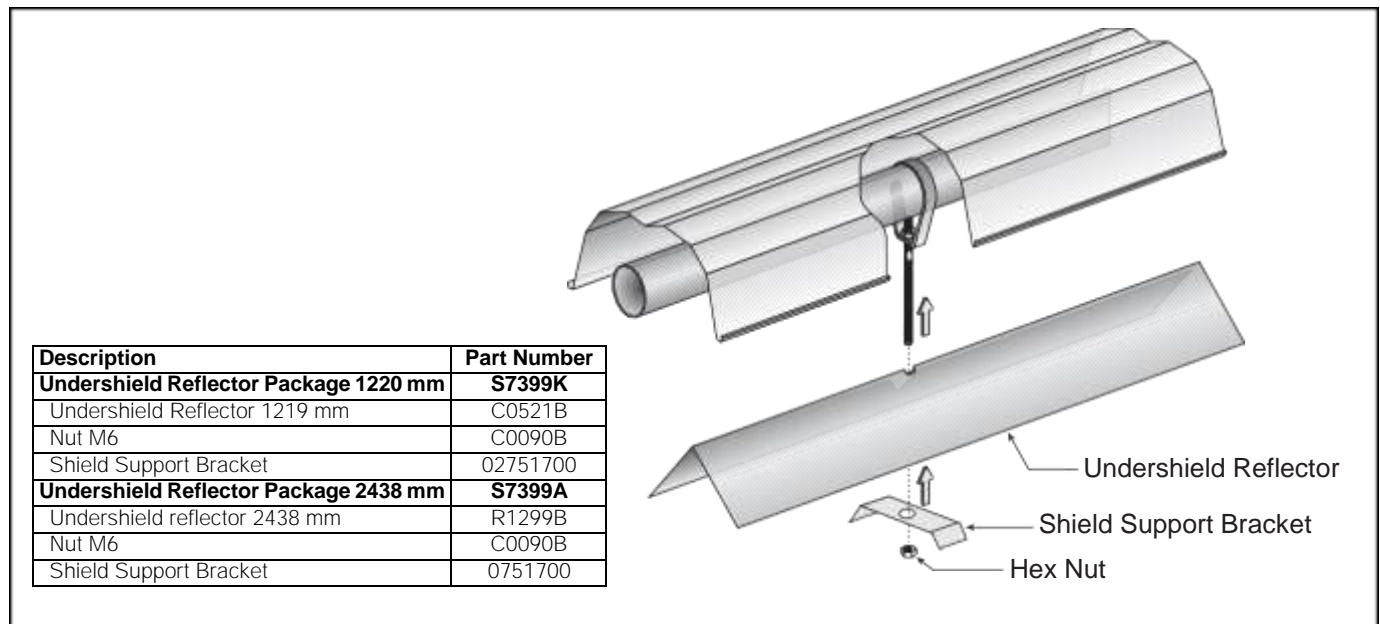

### 10.6.3 Adjust Undershield Height

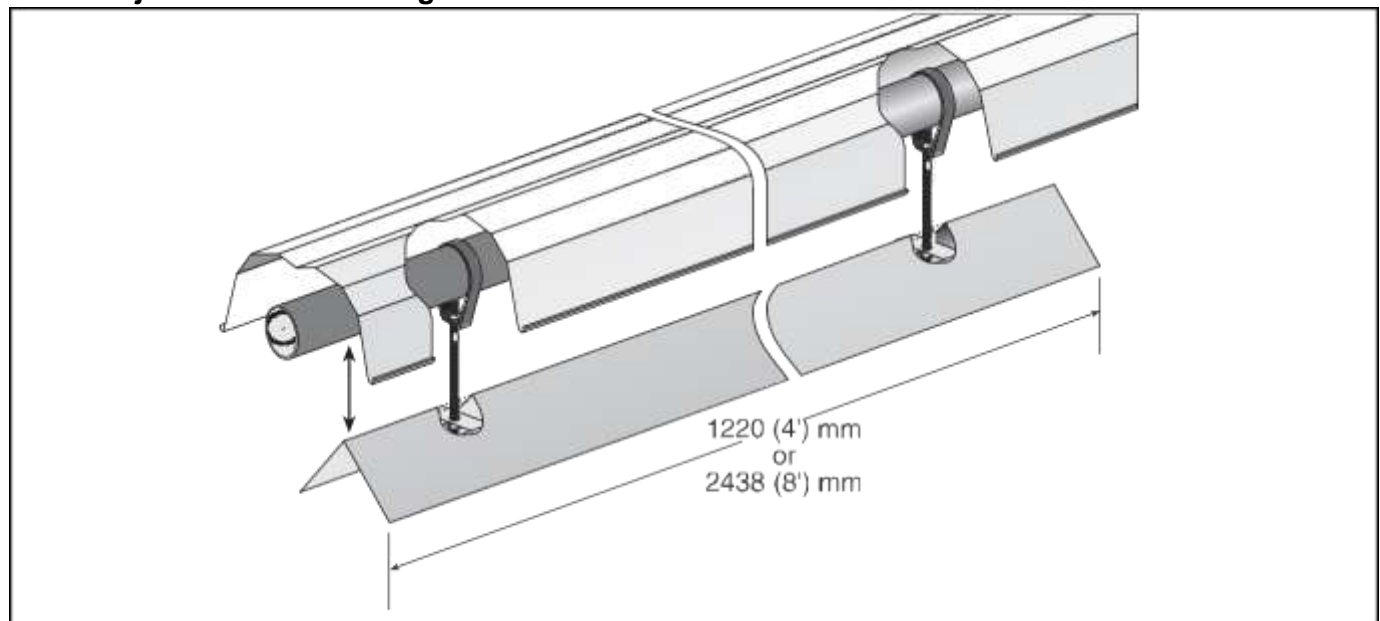

**10.7 Wall Mounting**

Install wall mounting brackets at the height shown in the layout drawing provided by the estimator. Space wall mounting brackets and hangers as indicated by dimensions d, e and f (u-tube) in the relevant layout overview drawing for your heater. For linear heaters see Page 15, Figure 20, for double linear heaters see Page 18, Figure 22 and for U-tube heaters see Page 27, Figure 24.

**10.7.1 Hardware Installation**

The wall mounting brackets must be attached to a suitable wall through all mounting holes. Screw sizes less than M8 (5/16") may not be used. In order for the wall

mounting brackets to adequately carry the weight of the heater, it must be installed with best building practice.

Model	Quantity of Wall Mounting Brackets	Model	Quantity of Wall Mounting Brackets
ATH15UT	2	ATH15ST	3
ATH20UT	3	ATH20ST	4
ATH25UT	3	ATH25ST	4
ATH30UT	3	ATH30ST	5
ATH35UT	3	ATH35ST	5
ATH40UT	3	ATH40ST	5
ATH45UT	4	ATH45ST	6
ATH50UT	4	ATH50ST	6

**Figure 27: U-Tube (Horizontal)**

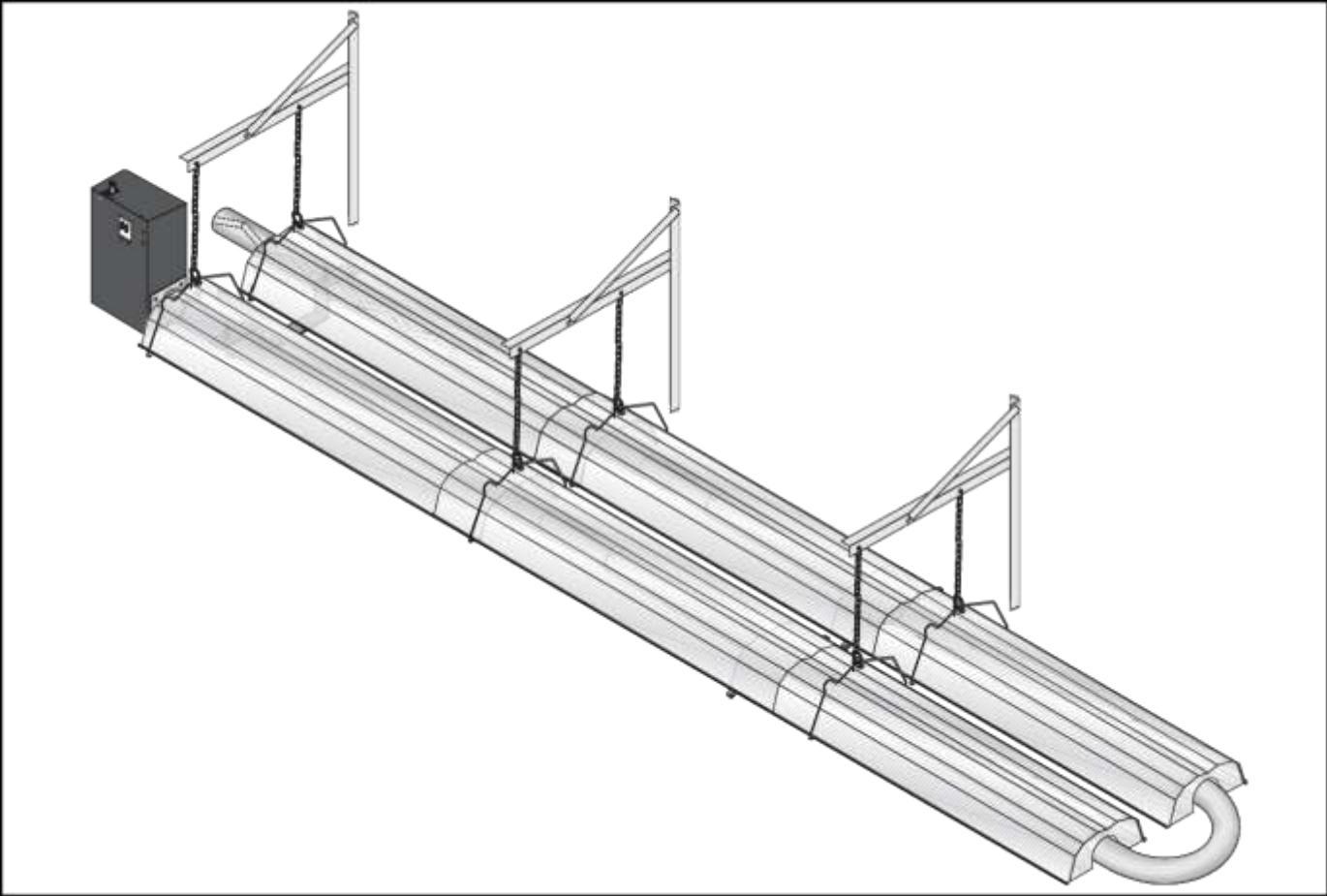

**Figure 28: U-Tube (Angle Mounted)**

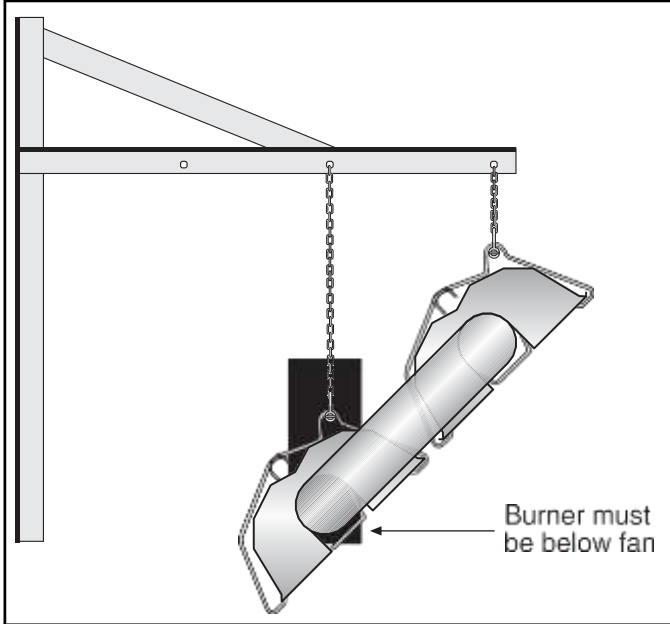

**Figure 29: Linear**

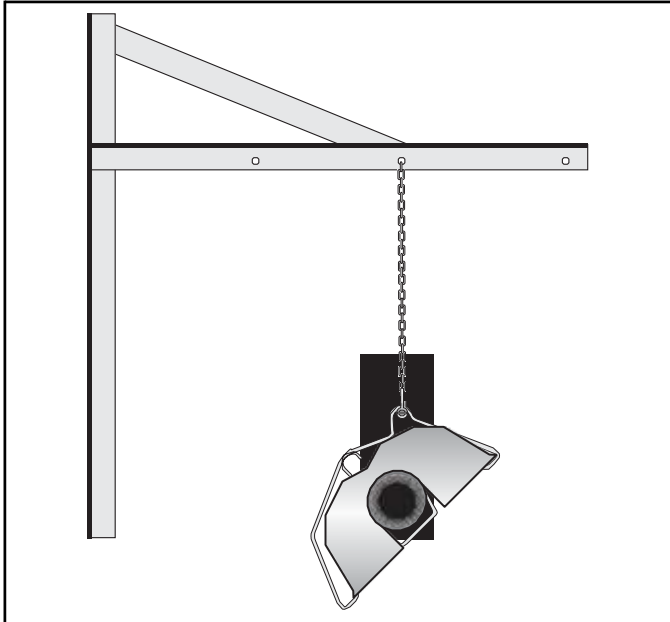

## SECTION 11: VENTING

**WARNING****Carbon Monoxide Hazard**

**Multiburner systems are not approved for unvented use and must be vented outdoors.**

**Unitary heaters installed unvented must be interlocked with sufficient building exhaust.**

**Heaters must be installed according to the installation manual.**

**Failure to follow these instructions can result in death or injury.**

**WARNING****Cut/Pinch Hazard**

**Wear protective gear during installation, operation and service.**

**Edges are sharp.**

**Failure to follow these instructions can result in injury.**

**11.1 General Venting Requirements**

Flue materials are not included with the heater.

**11.1.1 Type C<sub>12</sub>, C<sub>32</sub> & C<sub>62</sub> Appliance**

Room Sealed

The heaters are designed to be installed as room sealed appliances. The flue and air intake are run as separate pipes to the special concentric wall or roof terminal. The wire mesh inside the fresh air adapter on the heater must be removed prior to installation. *See Page 51, Figure 33.*

**11.1.2 Type B<sub>22</sub> Appliance**

The flue must be fitted with a low resistance terminal. *See Page 51, Figure 33.*

**11.1.3 Flue Installation**

The fan outlet may discharge vertically or horizontally. Connection should be made using 100 mm minimum diameter aluminium or stainless steel flue material to National Standard and must be adapted to insert into the 100 mm flue adapter. Both fresh air supply and flue duct shall not exceed 10,000 mm. ATH15 and ATH20 flue must

be insulated if longer than 5,000 mm. ATH25 flue must be insulated if longer than 8,000 mm. Contact the manufacturer if more than 2 x 45° offset bends are necessary. The flue must be self supporting.

<b>Fans</b>	<b>Horizontal</b>	<b>Vertical</b>
83 BWLG	190 x 75 (hole)	150 mm dia.
90 BWTL	190 x 75 (hole)	150 mm dia.

**11.1.4 Flueless Installation**

If the heater is being installed in an area where combustion products can be dissipated within the building, ensure that the fan outlet is horizontal and away from the burner. Where installation is close to a wall (perimeter system) or other obstruction close to the fan outlet or wall angle mounted, install the heater so that the fan tube is the furthest away from the wall or obstruction, i.e. the fan will always blow into the building or away from the obstruction.

**11.2 Ventilation Requirements**

Detailed recommendations for air supply are given in the relevant National Standards. There must be an adequate supply of air for both combustion and general ventilation. Air vents should have negligible resistance. Do not locate air vents where they can be easily blocked or flooded, or adjacent to any flues or extraction systems carrying flammable vapour.

**11.2.1 Flue Installation**

For design air changes less than 0.5/h following requirements apply.

Type B heaters

For natural ventilation low level openings must be provided of at least 2 cm<sup>2</sup>/kW input installed. For mechanical ventilation an air change rate of at least 0.5/h must be ensured.

Type C heaters

Room sealed heaters need no additional building ventilation.

**11.2.2 Flueless Installation (EN 13410)**

The installation room must have a volume of at least 10m<sup>3</sup>/kW of installed nominal heat input. A minimum of 10m<sup>3</sup>/h of exhaust air per kW of operating heat input must be ventilated out of the installation room by either thermal or mechanical evacuation. Appropriate exhaust and fresh air openings must be provided and exhaust fans interlocked with the operation of the heating equipment. Further no exhaust system is necessary if the building air change rate is greater than 1.5 per hour or the density of operating heat input is not greater than 5 W/m<sup>3</sup>.

**Figure 30: Individual Flue Connection Detail**

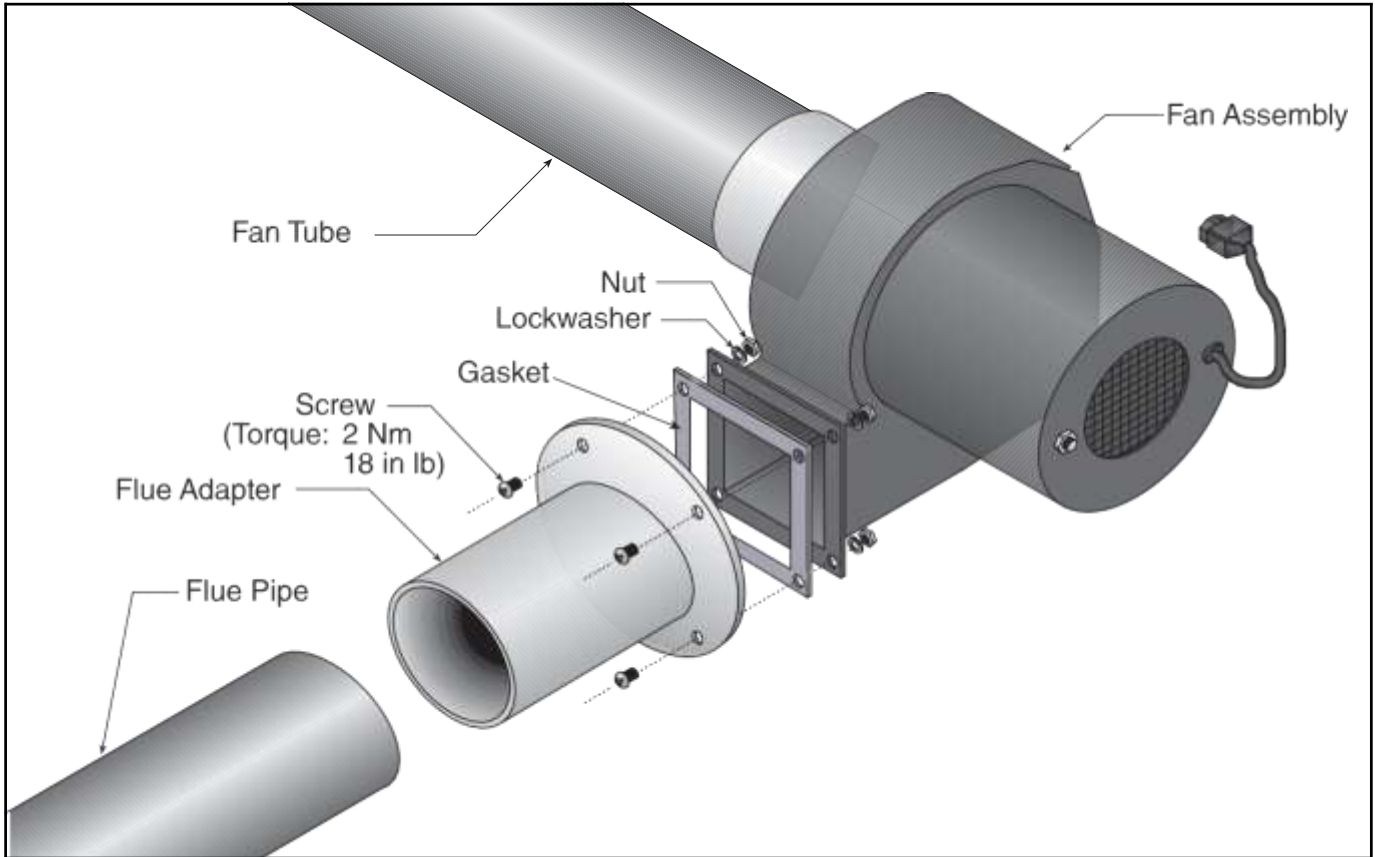

**Figure 31: Flue Connection Dimensions**

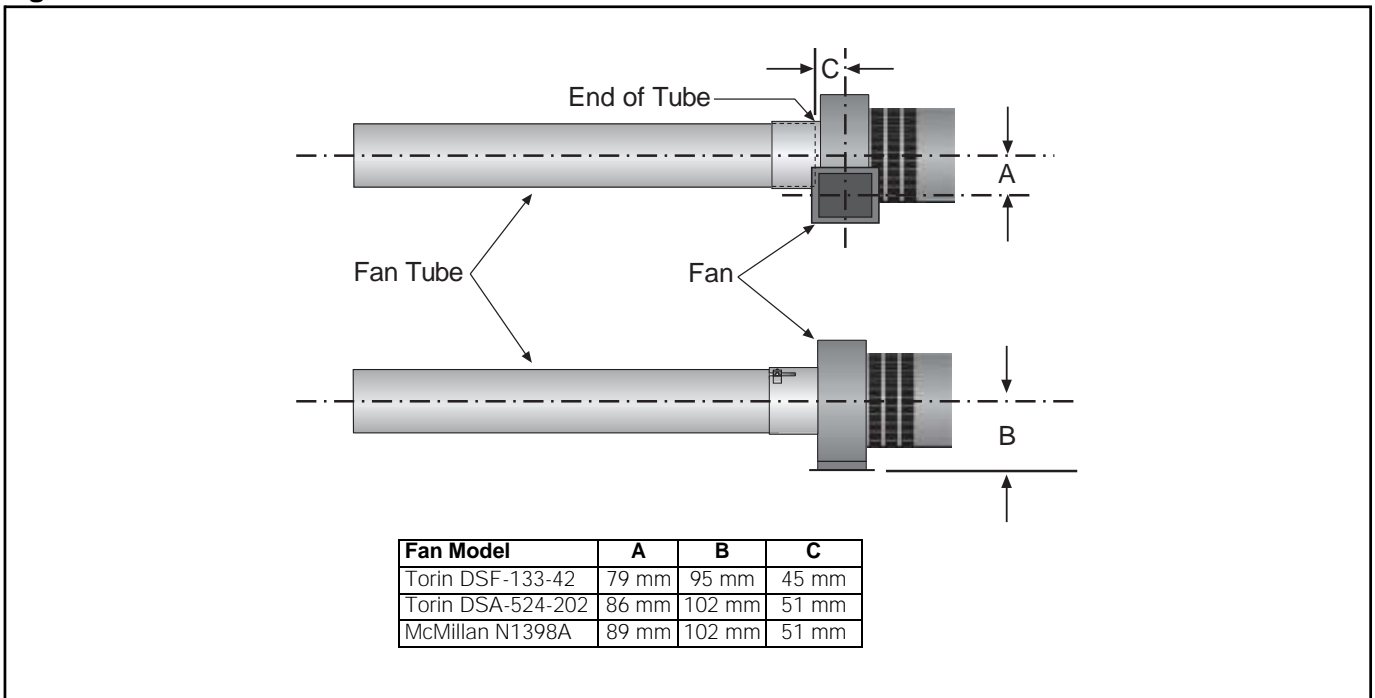

**113 Outside Combustion Air Supply**

Where necessary, clean air may be ducted into the burner box through an added spigot on the back of the burner box replacing the existing dust arrest baffle plate.

See Page 49, Section 11.1.3 for recommendations on duct length. Air duct should be as straight as possible. Do not use bends in excess of 45°. Consult the manufacturer if more than 2 x 45° offset bends are necessary. The fresh air duct must be self supporting.

**113.1 Air Supply Requirements**

When fresh air duct is used, follow one of these rules:

- The flue must penetrate the roof while fresh air can penetrate any wall. (See Page 51, Figure 33)
- The flue and fresh air supply must penetrate the same roof, at a minimum of 1 m apart. (See Page 51, Figure 33)
- The flue must penetrate 1 m higher than the fresh air inlet on the same wall. (See Page 51, Figure 33)

Figure 32: Fresh Air Intake Spigot

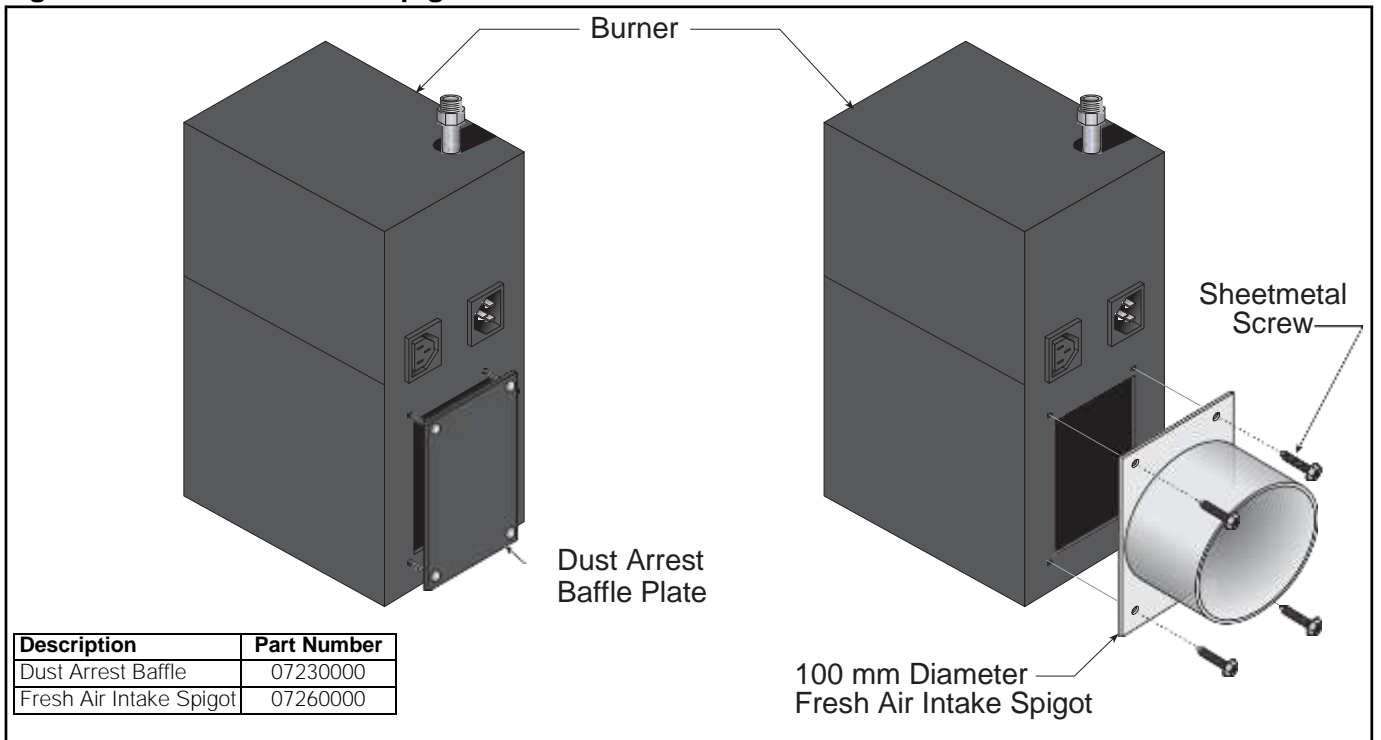
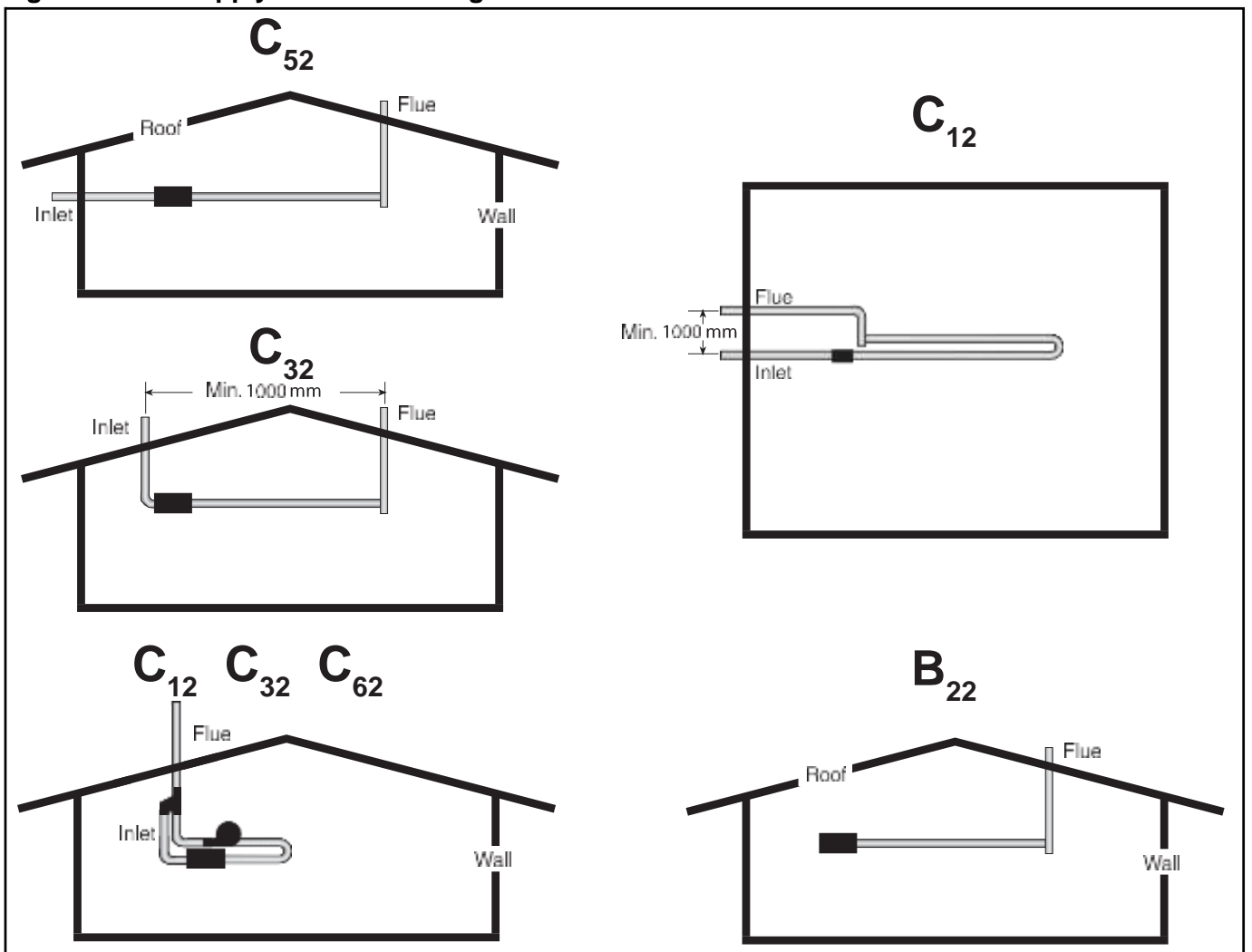

Figure 33: Air Supply with Flue Configurations



#### 11.4 Common Duct

When using a common air inlet duct, always ensure that the area of the common air inlet duct represents the area of all air ducts.

## SECTION 12: GAS PIPING

**WARNING****Fire Hazard**

**Tighten gas line fittings to connect gas supply according to Figure 34.**

**Flex gas line can crack when twisted.**

**Gas line moves during normal operation.**

**Use only 1000 mm long connector of 1/2" or 3/4" nominal ID.**

**Failure to follow these instructions can result in death, injury or property damage.**

hose. This can cause a gas leak resulting in an unsafe condition if the gas connection is not made in strict accordance with *Figure 34*.

Meter and service must be large enough to handle all the burners being installed plus any other connected load. The gas hose which feeds the system must be large enough to supply the required gas with a maximum pressure drop of 13 mm wc. When gas piping is not included in the layout drawing, the local gas supplier will usually help in planning the gas piping.

IMPORTANT - the complete installation must be tested for gas soundness and be purged in accordance with local and national codes.

- **Check the pipe and tubing ends for leaks before placing heating equipment into service. When checking for gas leaks, use a soap and water solution; never use an open flame.**

**WARNING****Explosion Hazard**

**Leak test all components of gas pipe work before operation.**

**Gas can leak if pipe work is not installed properly.**

**Do not high pressure test gas pipe work with heater connected.**

**Failure to follow these instructions can result in death, injury or property damage.**

It is important that the gas supply pipe and electrical connections do not support any of the heater's weight.

Installation pipes should be fitted in accordance with National Standards. Pipe work from the meter to the heater(s) must be of adequate size. Pipes of smaller size than the heater inlet gas connection should not be used.

Install the gas hose as shown on *Page 53, Figure 34*. The gas hose accommodates expansion of the heating system and allows for easy installation and service of the burner. Before connecting the burners to the supply system, verify that all high pressure testing of the gas piping has been completed.

There is an expansion of the tube with each firing cycle. This will cause the burner to move with respect to the gas

**Figure 34: Gas Connection with Stainless Steel Flex Connector**

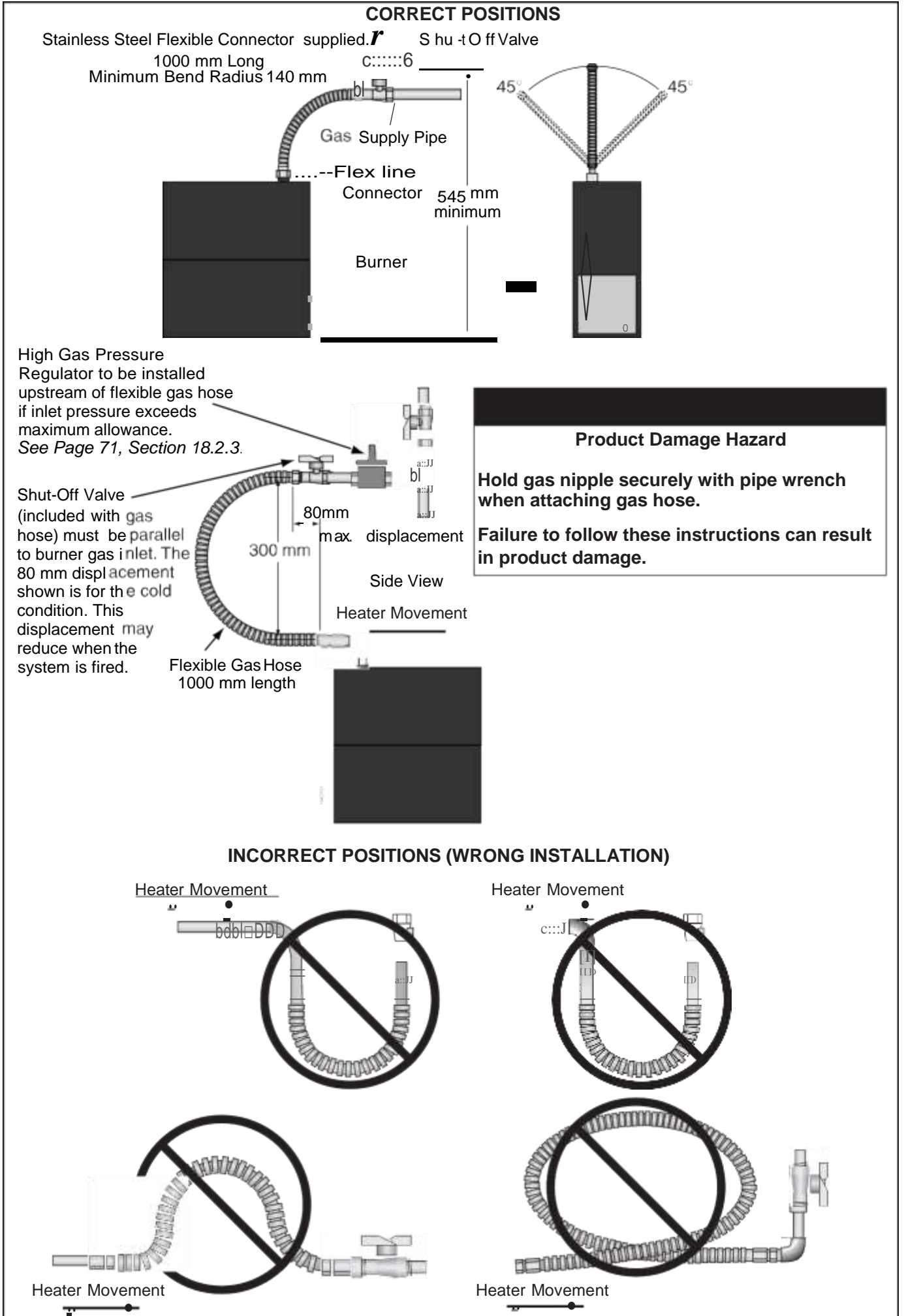



**SECTION 13: WIRING**

**DANGER**



**Electrical Shock Hazard**

**Disconnect electric before service.**

**Heater must be properly grounded.**

**Failure to follow these instructions can result in death or electrical shock.**

Connect to the electrical supply using a 3 pin plug via a locally mounted double pole fused switch having a minimum disconnection of 3 mm on each pole. This switch should be fused to 3 amps. The burner is fused at 2 amps. There are no control connections in the standard burner. Control is affected by interruption of the main power inlet. *See Page 54, Section 13.1 through Page 55,*

*Section 13.4* for the external wiring details for the single-burner, double linear and multiburner heater systems.

All wiring must comply with current wiring regulations and any local regulations which may apply. Always switch off the supply to the burner and disconnect by removing the plug before removing the burner side panel.

**13.1 Typical External Wiring Diagram (Linear or U-Tube)**

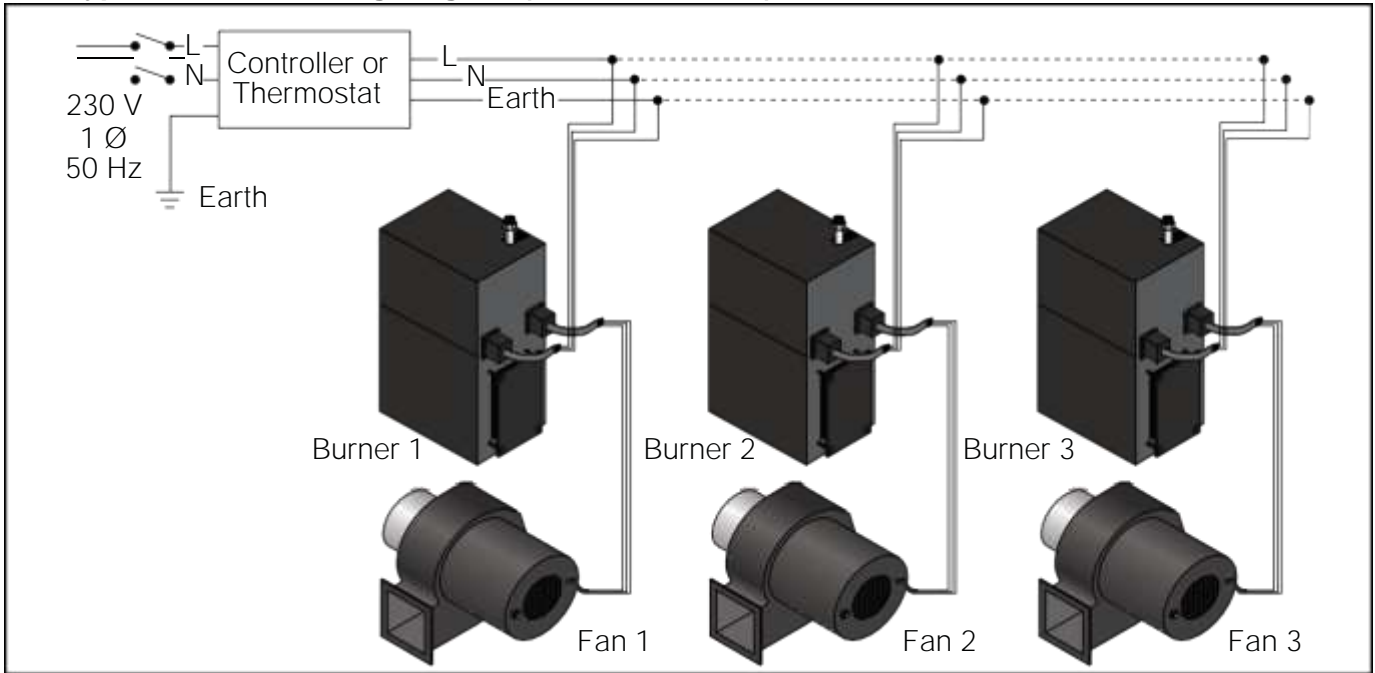

**13.2 Typical External Wiring Diagram (Double Linear Option 1)**

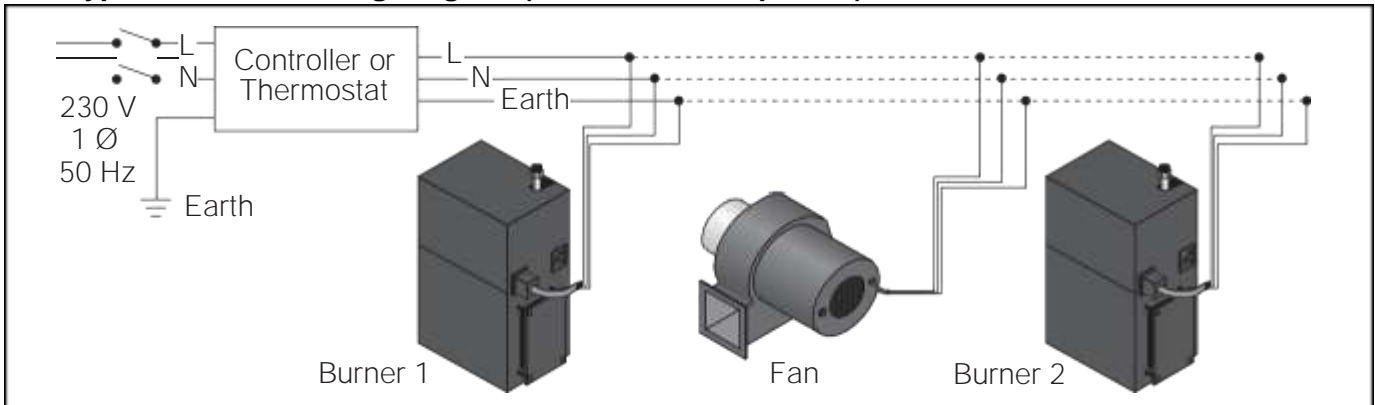

## 13.3 Typical External Wiring Diagram (Double Linear Option 2)

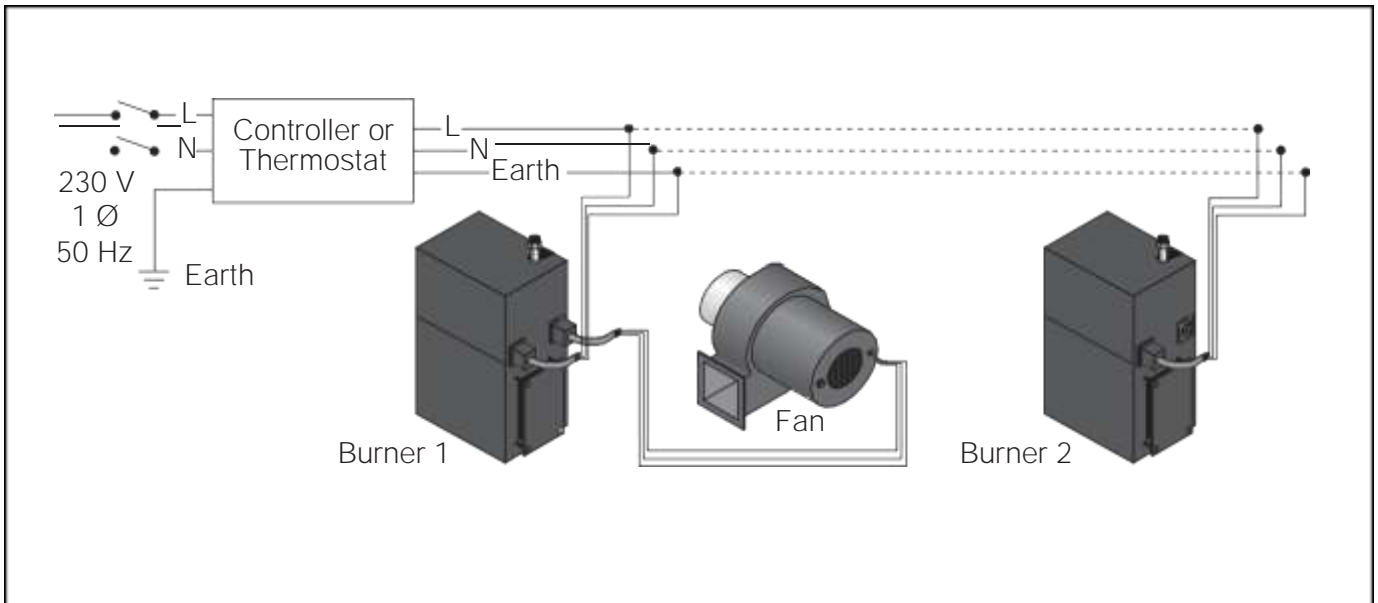

## 13.4 Typical External Wiring Diagram (Multiburner)

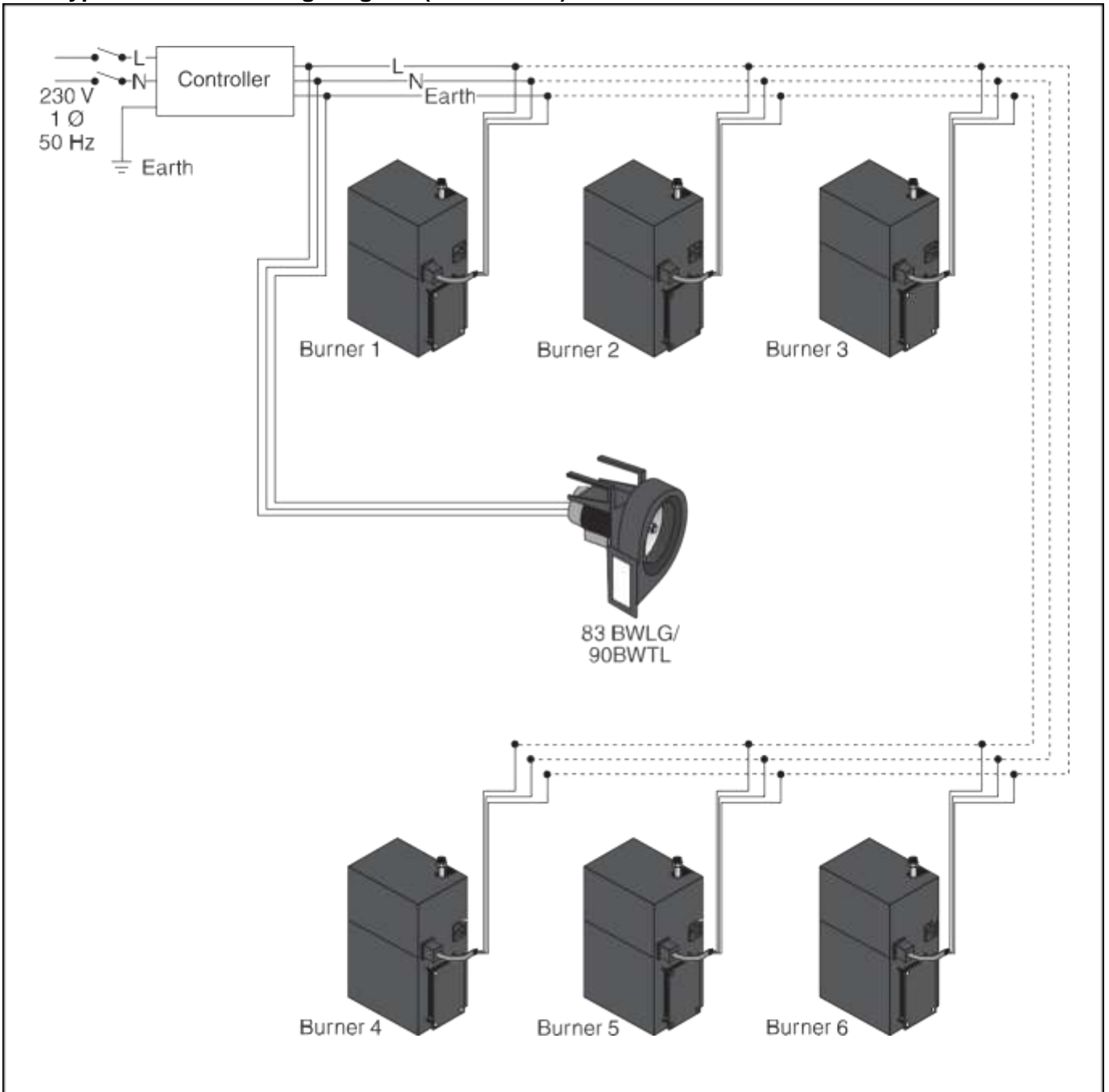

13.5 Internal Wiring Diagram

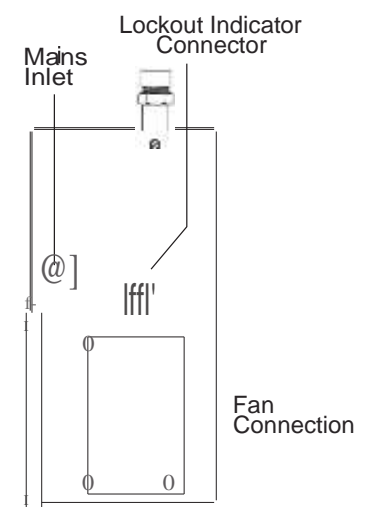
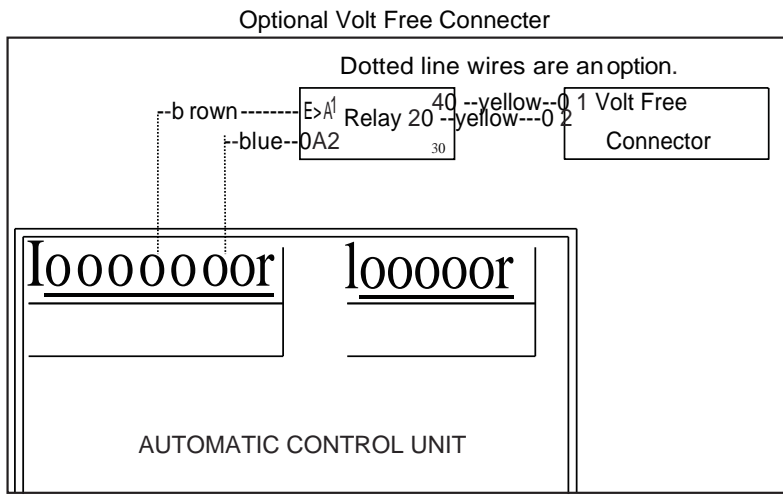
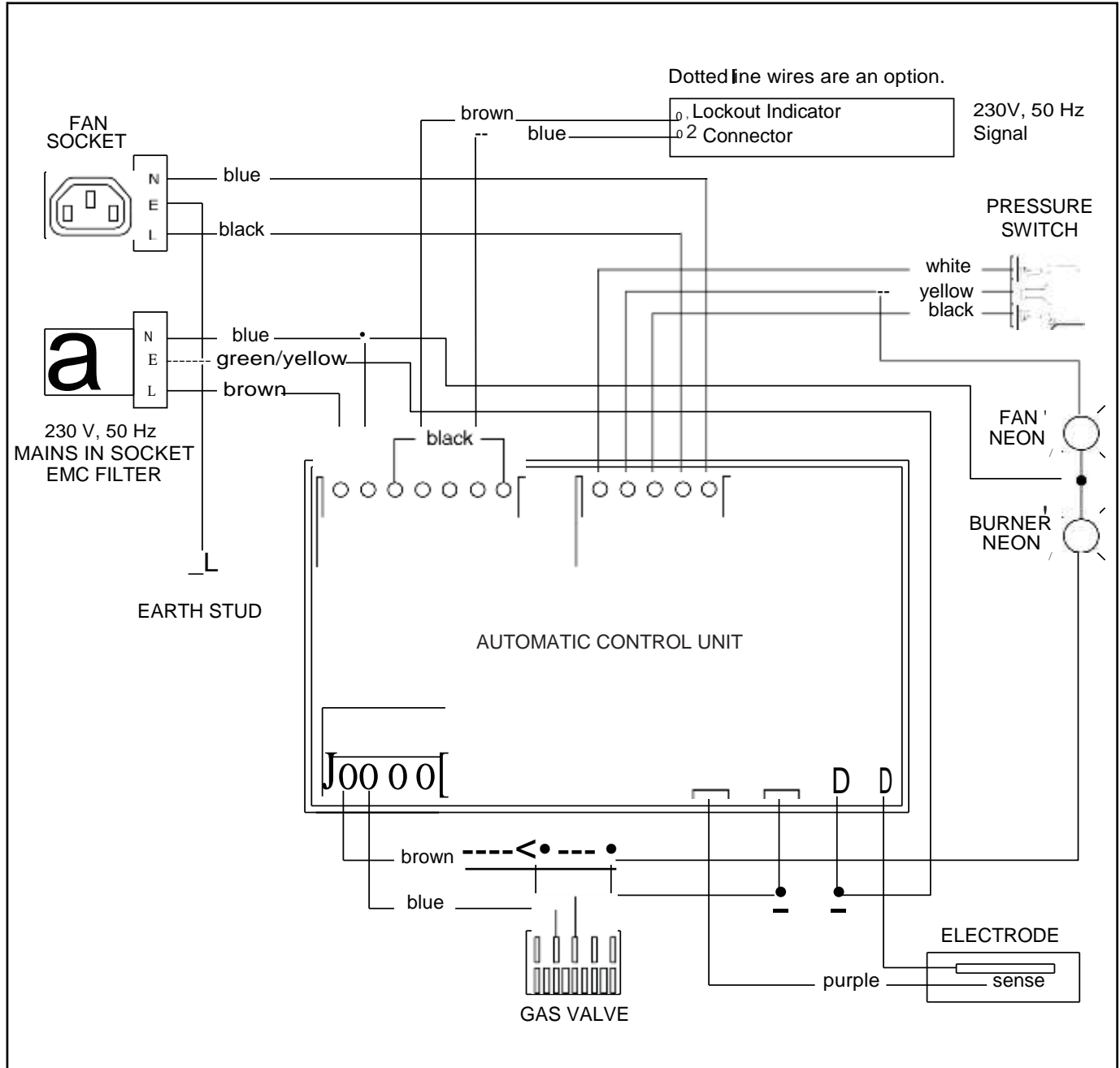

If any of the original wire as supplied with the heater must be replaced, it must be replaced with wiring material having a temperature rating of at least 105°C and 600 V.

SECTION 14: OPERATION





⚠ DANGER		⚠ WARNING	
			
<p><b>Electrical Shock Hazard</b></p> <p>Disconnect electric before service.</p> <p>More than one disconnect switch may be required to disconnect electric from heater.</p> <p>Heater must be connected to a properly grounded electrical source.</p>	<p><b>Explosion Hazard</b></p> <p>Turn off gas supply to heater before service.</p>	<p><b>Burn Hazard</b></p> <p>Allow heater to cool before service.</p> <p>Tubing may still be hot after operation.</p>	<p><b>Cut/Pinch Hazard</b></p> <p>Wear protective gear during installation, operation and service.</p> <p>Edges are sharp.</p>
<p>Failure to follow these instructions can result in death, electric shock, injury or property damage.</p>			

Figure 35: Sequence of Operation Chart



NOTE: If the heater operates for more than 24 hours continuously, the ignition module will automatically recycle the burner to ensure that all safety functions are still in working condition.

**14.1 Heater Lockout Indication (Optional)**

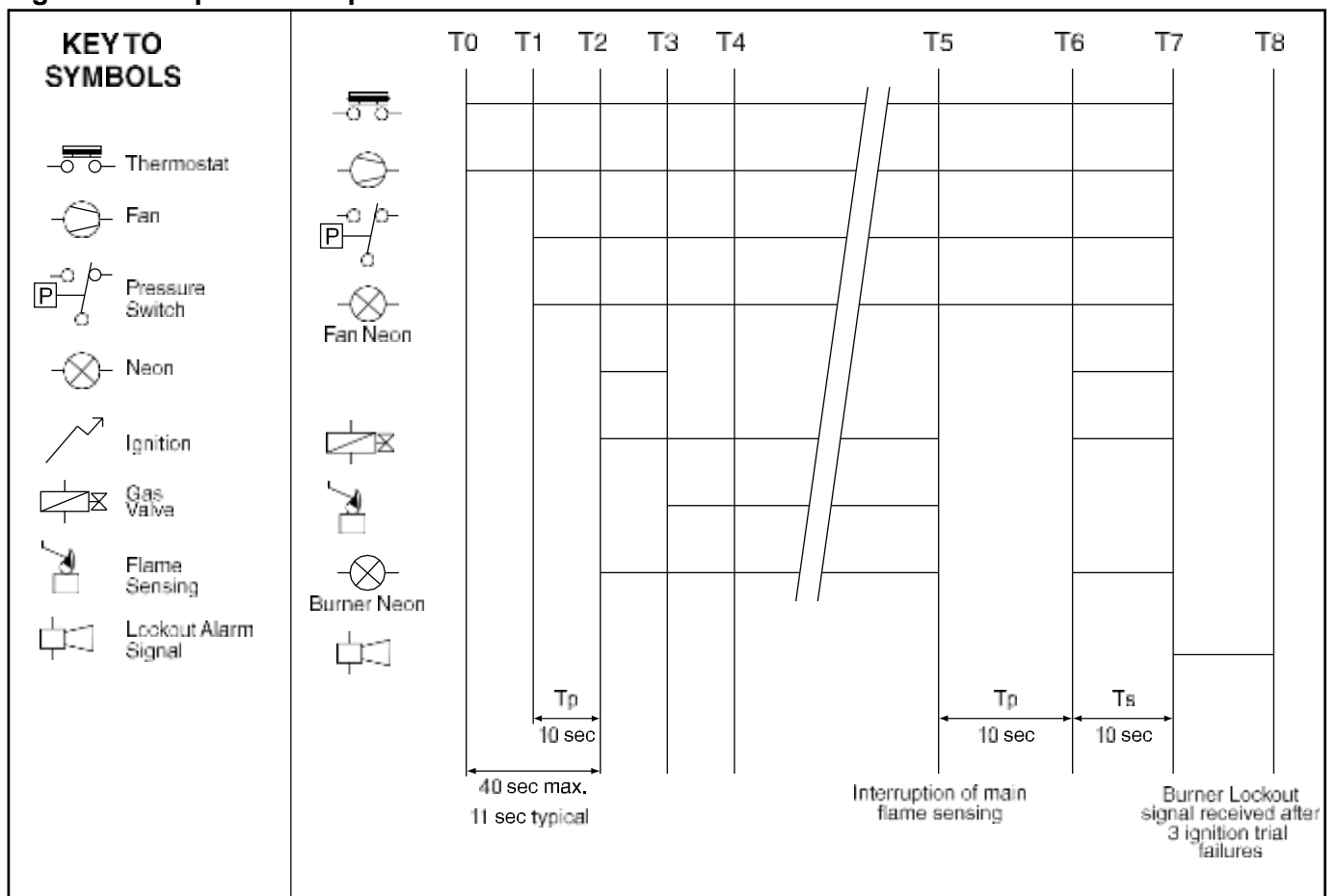
In case of flame loss during operation of the heater, the burner control unit goes to lockout mode after three ignition trials. At this stage a signal or closed relay will enable the Aira controller, BMS system, etc. to indicate

precisely which heater has failed. This can be done by two options.

### 14.1.1 Heater Lockout Indicator by Connector

A 230 V signal is provided which enables the Aira controller, BMS system, etc. to indicate the heater that has failed. An additional wire has to be installed from the heater lockout indicator connector to the monitoring computer. *See Page 56, Section 13.5.*

Description	Part Number
Connector male - Lockout Indicator	91324000
Connector female - Lockout Indicator	91324001
Wire Blue 12"	91300011
Wire Brown 12"	91300012

### 14.1.2 Heater Lockout Indicator by Volt Free Connector

A volt free contact relay is closed which enables the Aira controller, BMS system, etc. to indicate the heater that has failed. An additional wire has to be installed from the heater volt free connector to the monitoring computer. *See Page 56, Section 13.5.*

Description	Part Number
Connector male - Volt Free	91324000
Connector female - Volt Free	91324001
Wire Blue 7"	91300004
Wire Brown 7"	91300005
Wire Yellow 12"	91300003
Screw #8 x 3/8 Hex Wshr PHH Type 23	94961406
Base relay P2RF05E	C1050B
Relay G2R1-SN IMO 220 V 10 A	C1049B

### 14.2 Testing

Establish that a satisfactory purged gas supply and an electrical supply is available to the heater. Ensure that all time clocks and thermostats are set to call for heat.

With the gas supply cut off at the equipment isolating cock and the electrical supply isolated by switching off at the local switch and removing the appliance inlet plug, open the control chamber secured by the two screws. Loosen the sealing screw from the pressure test point and remove the cover cap from the governor.

Turn on the gas supply and connect equipment electrical plug. Ensure that the timer or thermostat, if fitted, are set to call for full gas rate. Switch on at the local switch. The sequence as described should take place. If not, refer to detailed fault finding sequence. When flame is established, check the gas pressure reading and adjust if necessary. Refer to burner data label.

Check the gas pressure at the outlet of the gas valve. *See Page 73, Section 18.10.1* for pressure settings or refer to the data plate.

Switch off the electrical supply (shutting down the heater), remove pressure gauge - tighten pressure test point screw, ensuring a tight gas seal. Replace governor cover cap. Close burner side cover.

### 14.3 Commissioning (Multiburner)

1. Establish that a satisfactory purged gas supply and an electrical supply is available to the heater.
2. ENSURE that all the dampers are in the fully open position.

3. With the gas supply off at each of the burners and the electrical supply isolated, open the control chamber secured by two self tapping screws.
4. Ensure that all time clocks and thermostats are set to call for heat.
5. Switch on the electrical supply at the main isolator. This will start the exhaust fan.

### 6. Balancing Cold Vacuum

Check each burner vacuum by connecting an inclined pressure gauge to the tee on the pressure switch inlet side in the burner. Adjust the damper so that the vacuum is 1.9 mbar. Repeat for each burner.

7. Starting at the end burner (furthest from the exhaust fan), with the inclined pressure gauge connected as described above. Turn on the gas supply and connect equipment electrical plug, reset the pressure switch by removing vacuum from the inlet side of the pressure switch waiting several seconds and reconnecting. The start up sequence described on *Page 57, Section 14* should take place. If not, refer to detailed fault finding sequence. When flame is established, check the gas pressure reading and adjust if necessary. See data label. Check the gas pressure at the outlet of the gas valve. *See Page 73, Section 18.10.1* for pressure settings or refer to the data plate. Switch off the electrical supply (shutting down the heater), remove pressure gauge - refit pressure test-point screw, ensuring a tight gas seal. Replace governor cover cap. Repeat this procedure for each burner in the system. Close the control chamber and secure with two sheet metal screws.

### 8. Balancing Hot Vacuum

Reconnect all the burners on the system and allow them to reach full operating temperature (approximately 20 minutes). Return to each burner and recheck the hot vacuum at the tee on the inlet to the pressure switch. Readjust the damper so that the hot vacuum of 1.5 mbar (2.0 mbar for ATH40EF) is achieved and lock the damper in position.

### 14.4 System Checks

Switch on again at the local switch to ensure smooth ignition. Carry out the following system checks:

When running, turn off the gas supply at the appliance. The heater will immediately shut down followed by three ignition attempts followed by lockout.

Linear and Double Linear only:





When running, disconnect the fan plug from the burner. The unit should shut down within three seconds, proving operation of the pressure switch.

### 14.5 User Instructions

After satisfactory testing, ensure that the client is fully aware of the operation of the system. Bring this manual to the attention of the user or purchaser; instruct them in the safe operation of the heater(s). Advise the user that if the

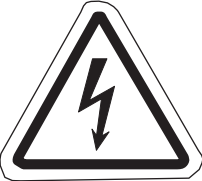
system is unflued, any reduction in the natural ventilation of the building may require a flue to be fitted, or additional ventilation grilles will be required.

**SECTION 15: SERVICING INSTRUCTIONS**

<b>⚠ DANGER</b>	<b>⚠ WARNING</b>		
			
<p><b>Electrical Shock Hazard</b></p> <p><b>Disconnect electric before service.</b></p> <p><b>More than one disconnect switch may be required to disconnect electric from heater.</b></p> <p><b>Heater must be connected to a properly grounded electrical source.</b></p>	<p><b>Explosion Hazard</b></p> <p><b>Turn off gas supply to heater before service.</b></p>	<p><b>Burn Hazard</b></p> <p><b>Allow heater to cool before service.</b></p> <p><b>Tubing may still be hot after operation.</b></p>	<p><b>Cut/Pinch Hazard</b></p> <p><b>Wear protective gear during installation, operation and service.</b></p> <p><b>Edges are sharp.</b></p>
<p><b>Failure to follow these instructions can result in death, electric shock, injury or property damage.</b></p>			

IMPORTANT: Never use the heater as a support for ladders or other access equipment. Always test for gas soundness with a suitable detection fluid after completing any servicing or exchange of gas carrying component. On completion of any service/fault finding tasks which require the breaking and remaking of electrical connections, the checks:- A:Earth Continuity, B:Polarity and C:Resistance to Earth must then be repeated.

**15.1 Annual Procedure**

Carry out the following procedure annually. The preferred time would be immediately before the winter heating period. If very dirty conditions arise, it may be necessary to carry out this procedure more often. If the unit takes in air through an air duct or filter assembly, more frequent service may be necessary.

**15.1.1 Burner and Fan Removal**

Isolate the heater from the gas and electrical supplies. Remove the fan plug from the burner. Unscrew the securing screws on the burner flange. The burner can now be removed. Take care not to disturb the gasket on the flanged burner tube. Unscrew the securing screw on the fan flange spigot. The fan can now be removed.

**15.1.2 Burner and Fan Removal Maintenance**

Remove the fan and burner independently to floor level and clean both items internally using a soft brush and compressed air, if available. Take care not to damage the internal parts of the burner. Check fan impeller for cleanliness and free rotation.

The electrodes are an integral part of the burner. To check spark gap, remove the securing screws on the electrode and withdraw it ensuring the gasket is not damaged. Spark gap on electrode should be approximately 3 mm.

**15.1.3 Tube and Reflector Maintenance**

With burner and fan removed, clean the outer surfaces of the tubes using a brush and wipe the inner surface of the reflector with a soft damp cloth - use a household detergent if necessary. Never use abrasive cleaners on the reflectors. Reassemble the burner and fan in reverse

order. Carry out the Testing Procedure. See Page 58, Section 14.2.

**15.2 Component Removal**

First, isolate the heater from the gas and electrical supplies. Entry to the burner assembly is gained by removing the door screws and opening the hinged side cover. Entry to the combustion chamber is gained by removing the combustion chamber cover.

**15.2.1 Electrode**

**Figure 36: Burner Cup Position**

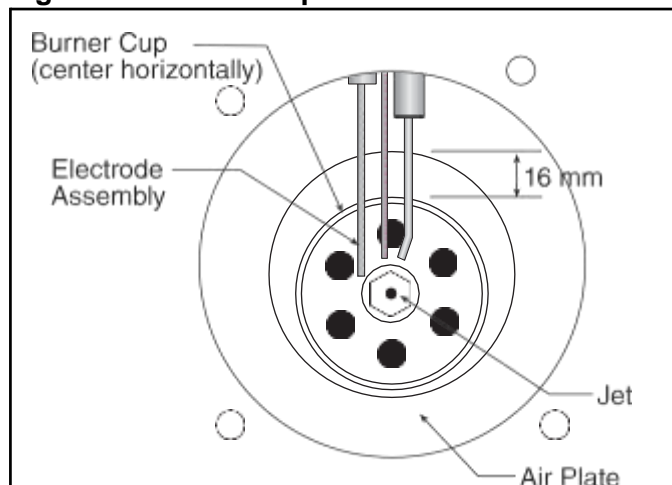

**15.2.2 Burner Head/Injector Jet**

When the cover is removed completely, the burner assembly is exposed. Unscrew the burner cup. Remove brass injector jet (orifice). Replace in reverse sequence.

**15.2.3 Solenoid Valve/Governor**

Remove burner head. Remove screws securing the solenoid/governor body bracket. Withdraw the four wires between the solenoids. The solenoid/governor and fittings can now be withdrawn from the compartment. The solenoid(s) can be removed from the body by unscrewing central screw. Replace in reverse sequence. Note: Earth is green/yellow.

**15.2.4 Automatic Flame Control Unit**

Remove black ignition lead. Withdraw the connectors. Remove two screws from the cover. Replace if faulty. Refit in reverse sequence.

**15.2.5 Pressure Switch**

Disconnect the two silicone tubes. Remove wires from the three blades. Remove two screws which secure the pressure switch to the burner. Remove pressure switch. Replace pressure switch, if faulty, and refit in reverse sequence ensuring that the rubber tubes are reconnected to the switch correctly.

**Note:** Wires fitted as follows:

- NO - Yellow
- NC - White
- Common - Black

**15.2.6 Neons**

Remove the two push on connectors and remove the neons by pushing downwards. Replace in reverse sequence.

**15.3 Maintenance Checklist****Installation Code and Annual Inspections:**

All installation and service of Aira equipment must be performed by a contractor qualified in the installation and service of equipment sold and supplied by Aira and conform to all requirements set forth in the Aira manuals and all applicable governmental authorities pertaining to the installation, service, operation and labeling of the equipment. To help facilitate optimum performance and safety, Aira recommends that a qualified contractor conduct, at a minimum, annual inspections of your Aira equipment and perform service where necessary, using only replacement parts sold and supplied by Aira.

---

**The Vicinity of the Heater** Do not store or use flammable objects, liquids or vapours near the heater. Immediately remove these items if they are present.

*See Page 5, Section 3.*

**Vehicles and Other Objects**

Maintain the clearances to combustibles.

Do not hang anything from, or place anything on, the heater.

Make sure nothing is lodged underneath the reflector, in between the tubes or in the decorative or protective grilles (included with select models).

Immediately remove objects in violation of the clearances to combustibles.

*See Page 5, Section 3.*

**Reflector**

Support reflector with hanger and support strap.

Reflector must not touch tube.

Make sure there is no dirt, sagging, cracking or distortion.

Do not operate if there is sagging, cracking or distortion.

Make sure reflectors are correctly overlapped. *See Page 23, Section 6.6.1. or Page 33, Section 7.8.1.*

Clean outside surface with a damp cloth.

**Vent Pipe**

Venting must be intact. Using a flashlight, look for obstructions, cracks on the pipe, gaps in the sealed areas or corrosion.

The area must be free of dirt and dust.

Remove any carbon deposits or scale using a wire brush.

*See Page 49, Section 11.*

**Outside Air Inlet**

Inlet must be intact. Look for obstructions, cracks on the pipe, gaps in the sealed areas or corrosion.

The area must be free of dirt and dust. Clean and reinstall as required.

---



<b>Tubes</b>	<p>Make sure there are no cracks.</p> <p>Make sure tubes are connected and suspended securely.</p> <p><i>See Page 11, Section 5.</i></p> <p>Make sure there is no sagging, bending or distortion.</p>
<b>Gas Line</b>	<p>Check for gas leaks. <i>See Page 52, Section 12.</i></p>
<b>Burner Observation Window</b>	<p>Make sure it is clean and free of cracks or holes.</p> <p>Clean and replace as required.</p>
<b>Blower Scroll, Wheel and Motor</b>	<p>Compressed air or a vacuum cleaner may be used to clean dust and dirt.</p>
<b>Burner Cup and Orifice</b>	<p>Clear of obstructions (even spider webs will cause problems).</p> <p>Carefully remove any dust and debris from the burner.</p>
<b>Electrode</b>	<p>Replace if there are cracked ceramics, excessive carbon residue, or erosion of the electrode.</p> <p>The electrode gap should be 3 mm.</p>
<b>Thermostat</b>	<p>There should be no exposed wire or damage to the thermostat.</p> <p><i>See Page 54, Section 13.</i></p>
<b>Suspension Points</b>	<p>Make sure the heater is hanging securely.</p> <p>Look for signs of wear on the chain or ceiling.</p> <p><i>See Page 11, Section 5.</i></p>
<b>Sports Hall Guard, Decorative and Protective Grilles (optional)</b>	<p>The grille must be securely attached. If the grille is loose or off, contact a contractor qualified in the installation and service of gas-fired heating equipment for repair.</p> <p>Check that side reflector extensions are installed correctly and secured in place if necessary (decorative grille only).</p> <p><i>See Page 41, Section 10.1 and Page 44, Section 10.4.</i></p> <p>Make sure shield is installed correctly and secured in place if necessary. (Decorative grille only.) <i>See Page 43, Section 10.3.2.</i></p>
<b>Wall Tag</b>	<p>If a wall tag is present, make sure it is legible and accurate. Please contact Aira or your Aira independent distributor if you need a wall tag. <i>See Page 4, Section 2.1.</i></p>
<b>Safety Labels</b>	<p>Product safety signs or labels should be replaced by the product user when they are no longer legible. Please contact Aira or your Aira independent distributor to obtain replacement signs or labels. <i>See Page 2, Figure 1 through Page 3, Figure 2.</i></p>

---



## SECTION 16: TROUBLESHOOTING

**DANGER****Electrical Shock Hazard**

Disconnect electric before service.

Heater must be properly grounded.

Failure to follow these instructions can result in death or electrical shock.

**WARNING****Fire Hazard**

Keep all flammable objects, liquids and vapors the minimum required clearances to combustibles away from heater.

Some objects will catch fire or explode when placed close to heater.

**Explosion Hazard**

Turn off gas supply to heater before service.

**Burn Hazard**

Allow heater to cool before service.

Tubing may still be hot after operation.

**Cut/Pinch Hazard**

Wear protective gear during installation, operation and service.

Edges are sharp.

Failure to follow these instructions can result in death, injury or property damage.

16.1 Troubleshooting Flow Chart (Linear, Double Linear and U-Tube)

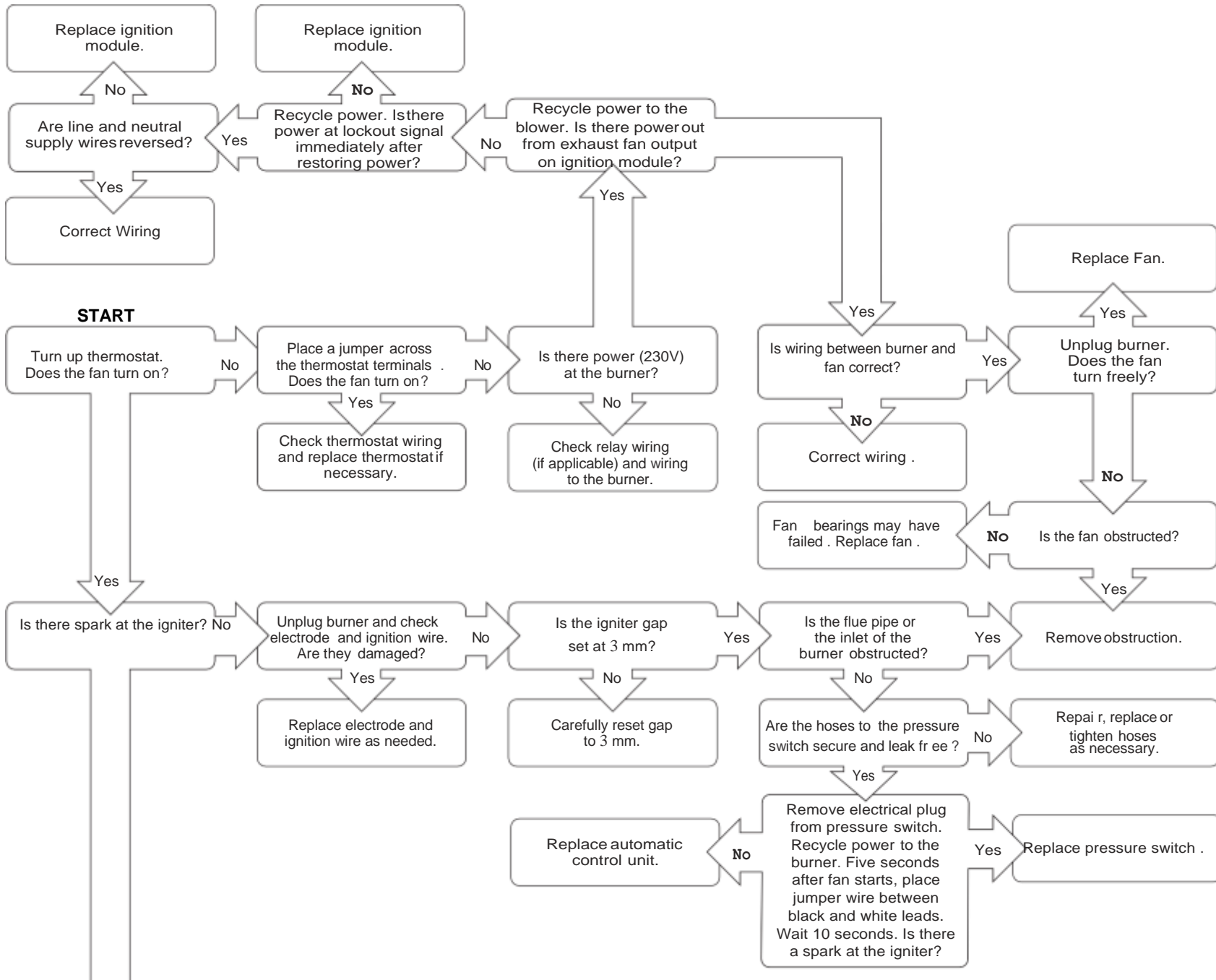

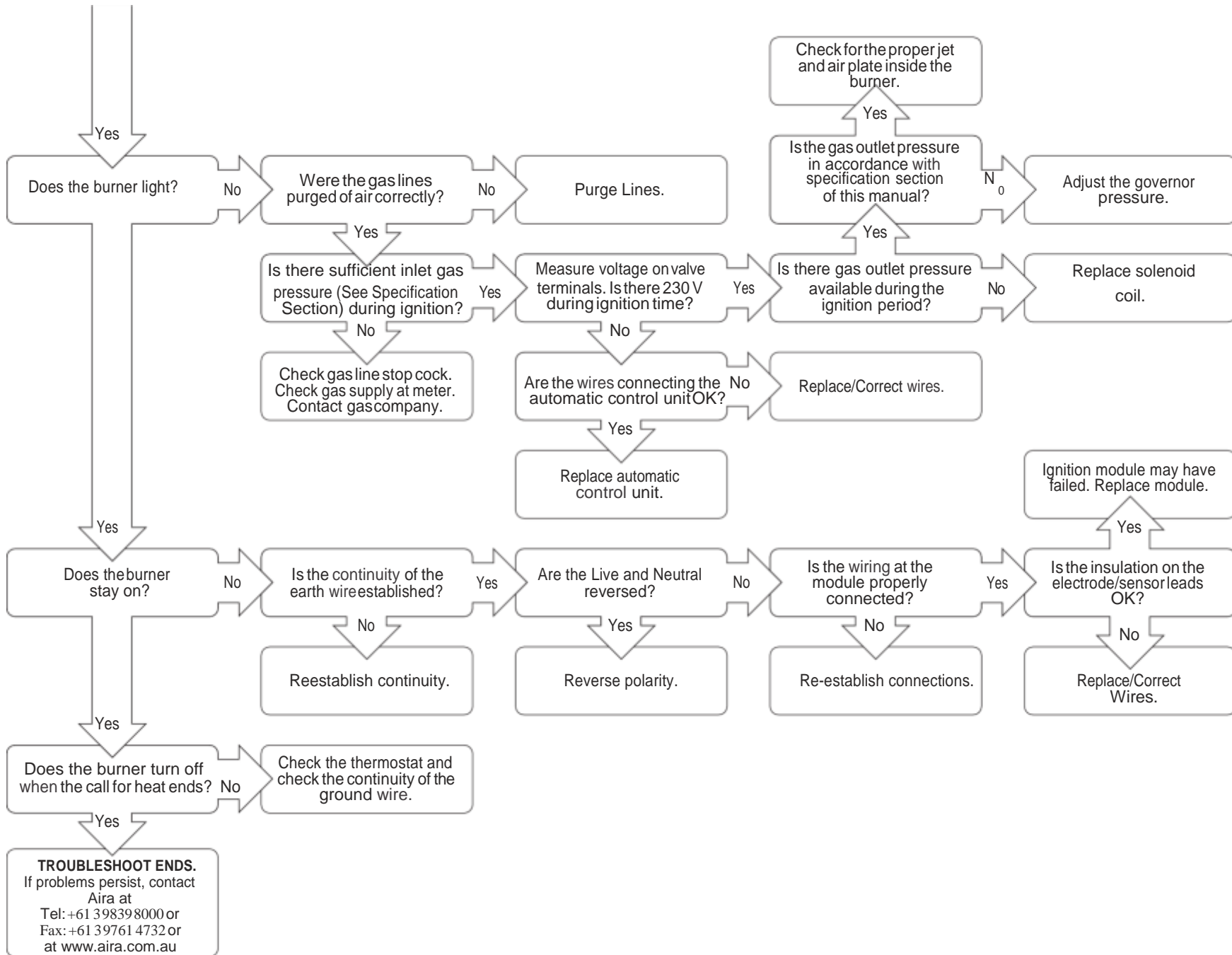

16.2 Troubleshooting Flow Chart (Multiburner)

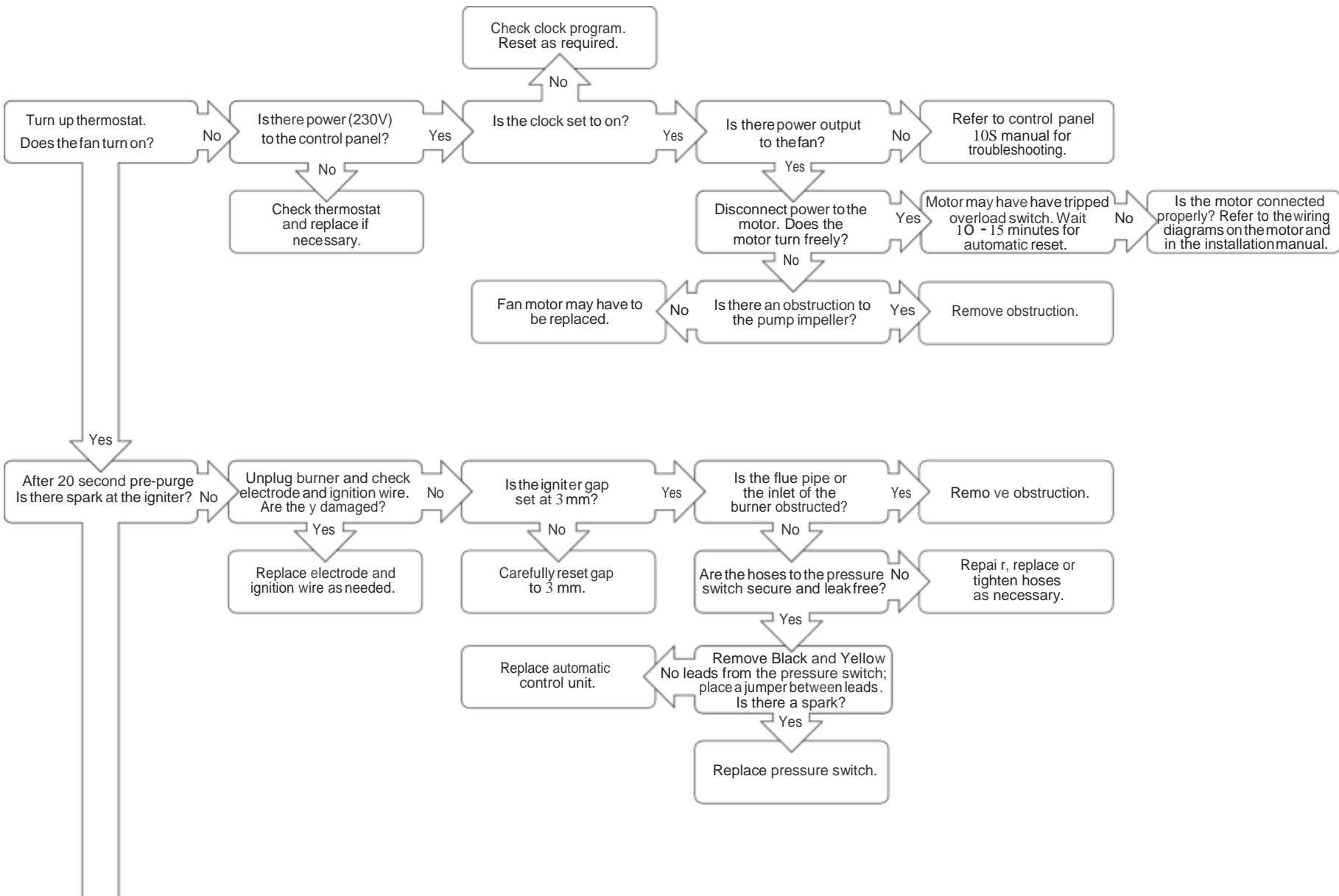

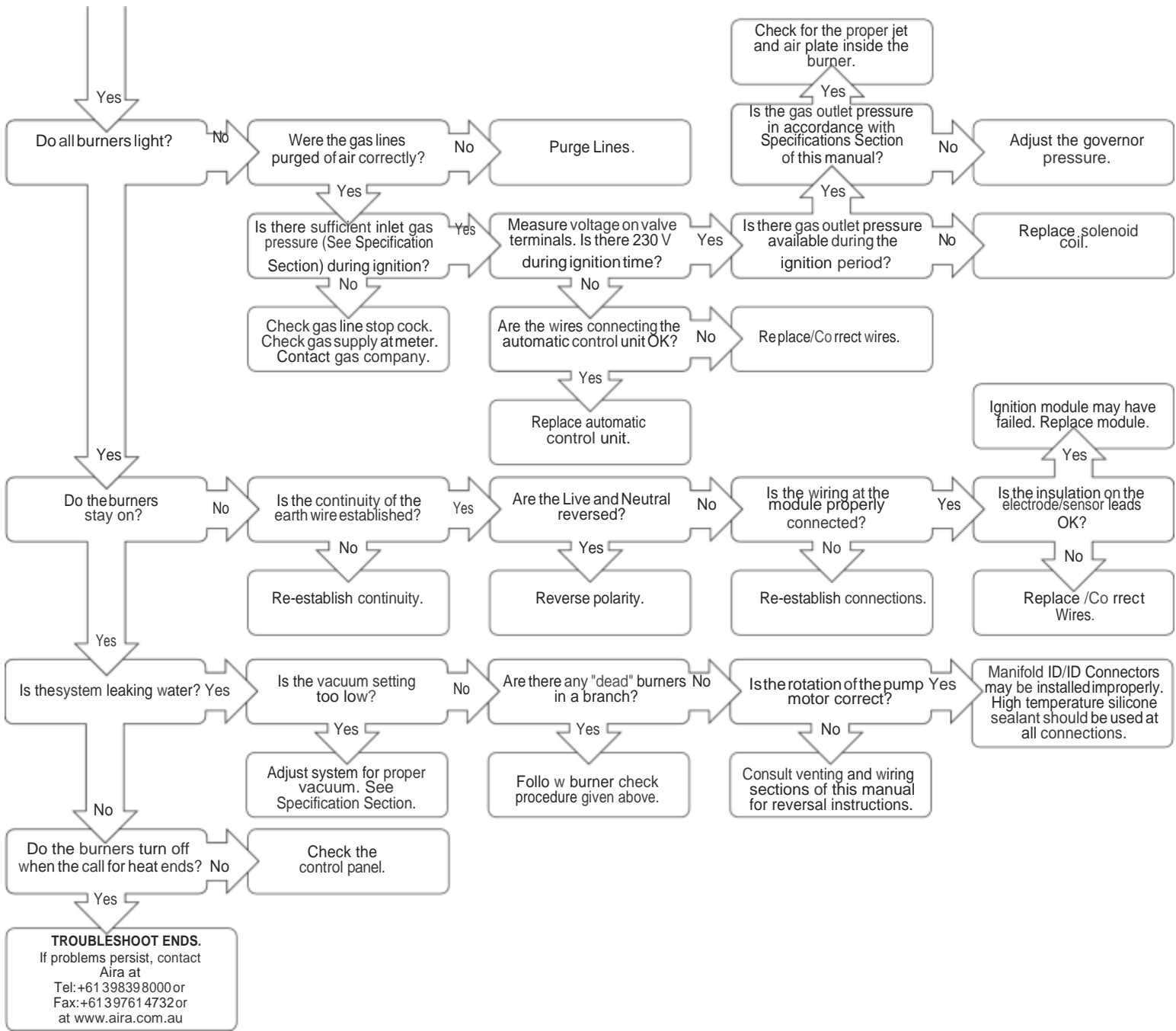



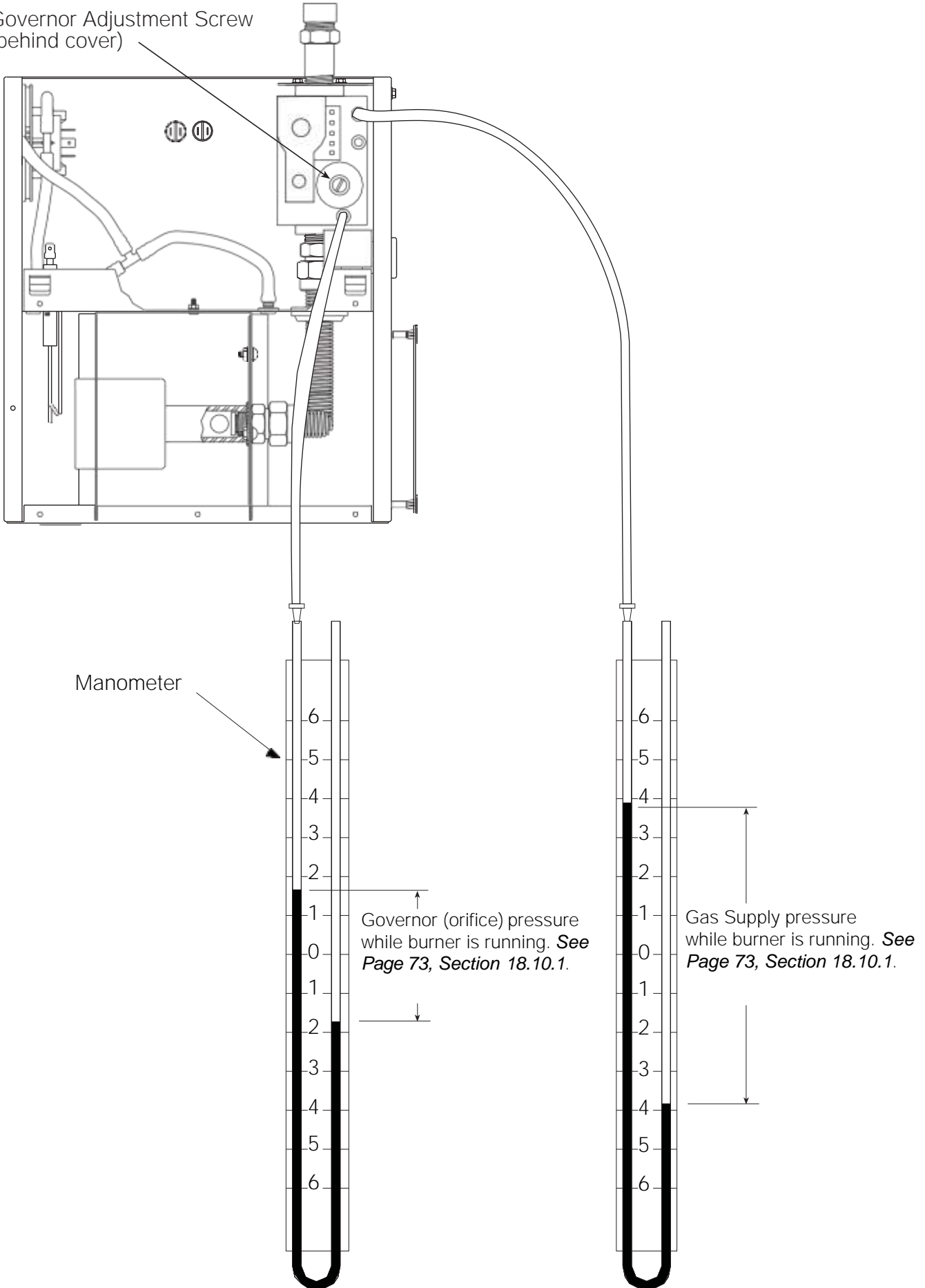

### 16.3 Manifold Gas Pressure Setting

Governor Adjustment Screw  
(behind cover)



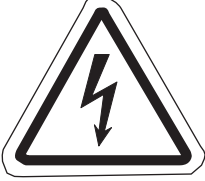

## SECTION 17: REPLACEMENT PARTS

<b>⚠ DANGER</b>		<b>⚠ WARNING</b>	
			
<b>Electrical Shock Hazard</b>	<b>Explosion Hazard</b>	<b>Fire Hazard</b>	<b>Carbon Monoxide Hazard</b>
<b>Use only genuine Aira replacement parts per this installation, operation and service manual.</b>			
<b>Failure to follow these instructions can result in death, electric shock, injury or property damage.</b>			

See warnings and important information before removing or replacing parts. After any maintenance or repair work, always test fire the heater in accordance with the start-up instructions *Page 57, Section 14* to help ensure all safety systems are in working order before leaving the heater to operate. Minor faults may be traced by using the troubleshooting charts *Page 63, Section 16 through Page 68, Figure 16.3*.

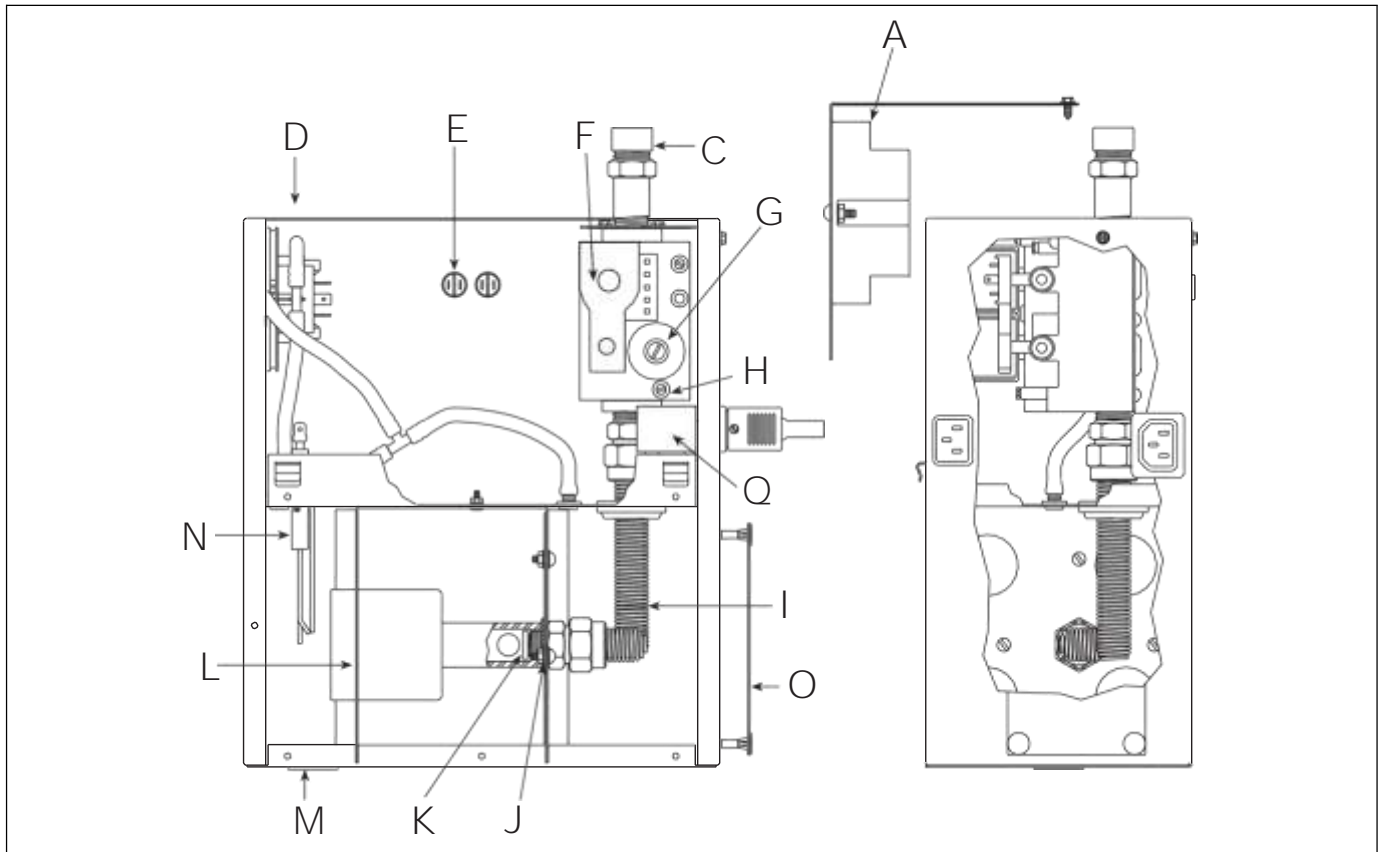

Item	Description	Part Number	Item	Description	Part Number
A	Automatic Control Unit	90438704	O	Dust Arrest Baffle Plate	07230000
C	Flex Line Adapter	91220700	Q	Mains in socket with EMC Filter	90438902
D	Pressure Switch for ATH25 - ATH50, (0.23" w.c.) ATH15 and ATH20 (0.32" w.c.) ATH30 and ATH35 (0.41" w.c.) ATH45 (0.47" w.c.) ATH40 (0.79" w.c.) ATH25 (0.59" w.c.)	90439801 90439802 90439803 90439804 90439808 90439809	N/S	Ignition Wire	90427704
E	Amber Neon Lamp	91320602	N/S	Outside Air Kit	07260000
F	Gas Valve	90033101	N/S	Flue Collar 100 mm	91911700
G	Governor Screw	N/A	N/S	Outside Air Mounting Plate	07261000
H	Outlet Pressure Tap	N/A	N/S	#8 x 3/8 Washer Head Screw	94118106
I	Flex Manifold	03090702T	N/S	Burner Tube Gasket	02568200
J	Star Washer	96212100	N/S	Wire Purple 12.5"	07250007
K	Jet Orifice (See Page 73, Section 18.10.1)	N/A	N/S	Wire Harness ATH Gas Valve	07250006
L	Burner Cup Assembly	03020100	N/S	Wire Harness ATH Pressure Switch	07250005
M	Mica Window Assembly	02552303	N/S	Wire Harness ATH Main Power	07250004
N	Electrode Assembly	90427403	N/S	Lockout Indicator Connector (male)	91324000
N/S	Electrode Gasket	02558501	N/S	Lockout Indicator Connector (female)	91324001

Notes:

**SECTION 18: SPECIFICATIONS****18.1 Material Specifications****18.1.1 Combustion and Tubes**

100 mm dia. 16 gauge heat treated aluminised mild steel.

**18.1.2 Reflectors**

NS3 H14 aluminium or 1.4016 2R stainless steel (option).

**18.2 Heater Specifications****18.2.1 Sequence Controller**

Fully automatic, three try, direct spark, 100% shut off ignition flame rectification module.

**18.2.2 Electrical**

Rating: 230V, 50 Hz, 1 Ø, 1 A

Connection: 3 pin moulded plug

**18.2.3 Gas Supply**

Connection: Rc1/2 (1/2" BSP int)

Natural G20:

Minimum - Inlet 1.1 kPa

Maximum - Inlet 5 kPa

LP Gas (Propane or Butane):

Minimum - Inlet 2.75 kPa

Maximum - Inlet 5 kPa

**18.3 Venting Specifications****18.3.1 Fans**

ATH-15, 20, 25, 30 ..... Model: Torin DSF 133-42

ATH-35, 40, 45 ..... Model: Torin DSA 524-202

ATH-50 ..... Model: McMillan N1398A

ATH-30DL, 40DL, 50DL,

60DL, 70DL ..... Model: McMillan N1398A

Multiburner ..... Model: Airflow 83 BWLG

..... Model: Airflow 90 BWTL

Consult the manufacturer for availability of alternate fans.

**18.3.2 Flue**

When fitted, the flue must be 100 mm, or greater in diameter, and must conform to National Codes. The flue must be self supporting. Inlet must be 100 mm diameter.

Multiburner - Flue must be 150 mm diameter and will be sized to suit arrangement and will connect to the fan. Flue material must conform to National Codes. The flue must be self supporting.

**18.4 Suspension Specifications**

Hang heater with materials with a minimum working load of 33 kg.

**18.5 Controls Specifications**

Time switches, thermostats, etc. can be wired into the electrical supply. External controls supplied as an optional extra.

**18.6 Environment**

The heater is limited to operate in an ambient temperature range of 0 °C – 30 °C with a maximum relative humidity of 95%.

**18.7 Linear Heater**

	ATH15ST	ATH20ST	ATH25ST	ATH30ST	ATH35ST	ATH40ST	ATH45ST	ATH50ST
Input - Gross (MJ/h)	54	72	90	108	126	144	162	180
Input - Net (MJ/h)	48.6	64.8	81	97.2	113.4	129.6	145.8	162
Tube Length (mm)	6096	9144	9144	12192	12192	12192	15240	15240
Overall Heater Length (mm)	6661	9709	9709	12757	12767	12767	15815	15850
Weight (kg)	39	55	55	68	68	68	81	81
Heated Area (m <sup>2</sup> )	20-160	30-210	40-265	50-315	55-370	65-420	70-475	80-525
Minimum Installation Height (mm)	3500	3500	3500	3500	4600	5000	5000	5000
Recommended Installation Height (mm)	3500	3600	3900	4200	4800	5500	6700	7600

\* Only available in Multiburner.

**18.8 Double Linear Heater**

	ATH30DL	ATH40DL	ATH50DL	ATH60DL	ATH70DL
Input - Gross (MJ/h)	108	144	180	216	252
Input - Net (MJ/h)	99	129.6	162	194.4	226.8
Tube Length (mm)	12802	18898	18898	24994	24994
Overall Heater Length (mm)	13462	19558	19558	25654	25654
Weight (kg)	82	110	110	136	136
Heated Area (m <sup>2</sup> )	50-315	65-420	80-525	100-630	110-740
Minimum Installation Height (mm)	3500	3500	3500	3500	4600
Recommended Installation Height (mm)	3500	3600	3900	4200	4800

**18.9 U-Tube Heater**

	ATH-15UT	ATH-20UT	ATH-25UT	ATH-30UT	ATH-35UT	ATH-40UT	ATH-45UT	ATH-50UT
Input - Gross (MJ/h)	54	72	90	108	126	144	162	180
Input - Net (MJ/h)	48.6	64.8	81	97.2	113.4	129.6	145.8	162
Tube Length (mm)	3531	5055	5055	6579	6579	6579	8103	8103
Overall Heater Length (mm)	3822	5346	5346	6870	6870	6870	8394	8394
Weight (kg)	41	54	54	65	65	66	96	96
Heated Area (m <sup>2</sup> )	20-160	30-210	40-265	50-315	55-370	65-420	70-475	80-525
Minimum Installation Height (mm)	3500	3500	4000	4700	5000	5000	5000	5000
Recommended Installation Height (mm)	3500	3600	4000	4700	5000	5500	6700	7600

## 18.10 Burner Specifications

Figure 37: Linear and U-Tube Specifications

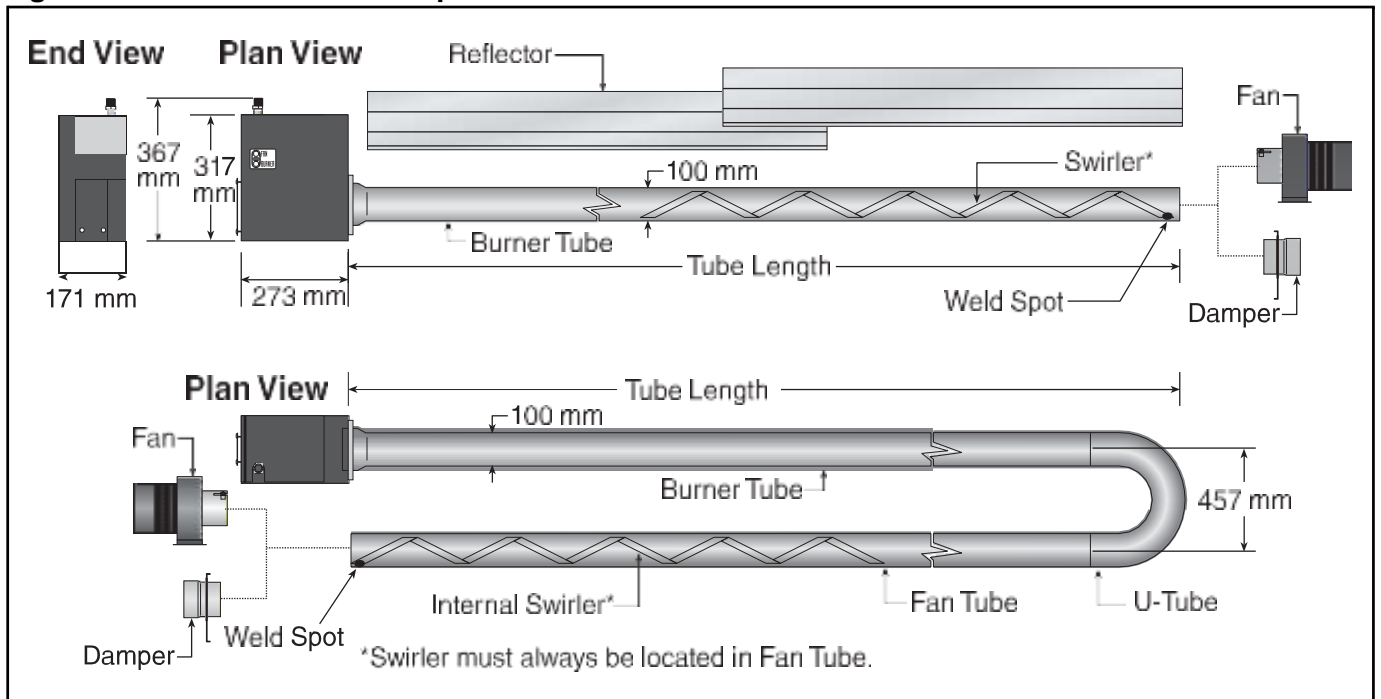

### 18.10.1 Standard Burner Specifications

	ATH15	ATH20	ATH25	ATH30	ATH35	ATH40	ATH45	ATH50
Burner Airplate ID Number	20	15	12	6	7	9	10	11
Jet Numbers - Natural G20	#30	3.8 mm	#19	4.7 mm	#9	#3	#2	B
Jet Numbers - Propane/Butane	#46	2.3 mm	#37	#33	3.1 mm	3.3 mm	#29	#26
Gas Consumption* Natural G20 (m <sup>3</sup> /h)	1.43	1.91	2.38	2.86	3.34	3.81	4.29	4.76
Gas Consumption* Propane (m <sup>3</sup> /h) [kg/h]	0.56 [1.08]	0.75 [1.44]	0.94 [1.80]	1.13 [2.16]	1.32 [2.52]	1.51 [2.88]	1.69 [3.25]	1.88 [3.61]
Gas Consumption* Butane (m <sup>3</sup> /h)	0.43	0.57	0.72	0.86	1.00	1.15	1.29	1.43
Governor Pressure Butane (kPa)	21.4	19.7	19.2	17.4	18.2	17.9	16.9	18.4
Governor Pressure Propane (kPa)	26.1	26.1	26.1	27.4	26.1	28.6	28.6	26.1

\*Based on Gross Caloric Value.

Natural G20: .087 kPa

Attach this information to a wall near the AIRA heater.



Read the Installation, Operation, and Service Manual thoroughly before installation, operation, or service.

Know your model number and installed configuration.

Model number and installed configuration are found on the burner and in the Installation, Operation and Service Manual.

Write the largest clearance dimensions with permanent ink according to your model number and configuration in the open spaces below.

#### OPERATING INSTRUCTIONS

1. STOP! Read all safety instructions on this information sheet.
2. Open the manual gas valve in the heater supply line.
3. Turn on electric power to the heater.
4. Set the thermostat to desired setting.

#### TO TURN OFF THE HEATER

1. Set the thermostat to off or the lowest setting.

#### IF THE HEATER WILL NOT OPERATE, TO ENSURE YOUR SAFETY, FOLLOW THESE INSTRUCTIONS TO SHUT DOWN YOUR HEATER

1. Set the thermostat to off or the lowest setting.
2. Turn off electric power to the heater.
3. Turn off the manual gas valve in the heater supply line.
4. Call your registered installer/contractor qualified in the installation and service of gas-fired heating equipment.

#### AWARNING



#### Fire Hazard

Keep all flammable objects, liquids and vapors the minimum required clearances to combustibles away from heater.

Some objects will catch fire or explode when placed close to heater.

Failure to follow these instructions can result in death, injury or property damage.

**Maintain \_\_\_\_\_ clearance  
to the side and  
\_\_\_\_\_ clearance below  
the heater from vehicles  
and combustible materials.**

**Aira Pty Ltd - Head Office**  
144 Colchester Road  
Kilsyth, VIC 3137  
Telephone: 61 3 9839 8000  
Fax: 61 3 9761 4732  
www.aira.com.au

**Aira Pty Ltd - New Zealand**  
Unit B, 50 Keeling Road  
Henderson, Auckland  
Telephone: (09) 835 2100  
Fax: (09) 835 2201  
www.aira.com.au

#### Installation Code and Annual Inspections:

All installation and service of AIRA equipment must be performed by a contractor qualified in the installation and service of equipment sold and supplied by Aira and conform to all requirements set forth in the AIRA manuals and all applicable governmental authorities pertaining to the installation, service, operation and labeling of the equipment. To help facilitate optimum performance and safety, Aira recommends that a qualified contractor conduct, at a minimum, annual inspections of your AIRA equipment and perform service where necessary, using only replacement parts sold and supplied by Aira.

Further Information: Applications, engineering and detailed guidance on systems design, installation and equipment performance is available through AIRA representatives. Please contact us for any further information you may require, including the Installation, Operation and Service Manual.

This product is not for residential use.

© 2014 Roberts-Gordon LLC All rights reserved. No part of this work covered by the copyrights herein may be reproduced or copied in any form or by any means - graphic, electronic, or mechanical, including photocopying, recording, taping, or information storage and retrieval systems - without written permission of Roberts-Gordon LLC.

www.aira.com.au

P/N 91037912-AH Orig