

SUBMITTAL DATA SHEET – CW-80 WITH MULTI-MAGIC CONTROLS

Job Name:

Order No.:

Project Manager:

Submitted To:

Date:

Special
Instructions:

Location:

Contractor:

Engineer:

Submitted By:

Asset ID:

MODEL	QUANTITY
CW-80 IEC Standard Fans	
CW-80 Supercool Standard Fans	
CW-80 IEC High-Capacity Fans	
CW-80 Supercool High-Capacity Fans	

COOLING APPLICATION

Standalone Pre-Cooling Supplementary

DESIGN CONDITIONS

Outdoor Ambient Conditions:

Dry Bulb °F

Wet Bulb °F

Elevation Above Sea Level ft

Fan Duty Point:

Supply Air Volume cfm

External Static Pressure in.wg

Performance:

Supply Air Temperature °F

Pre-Cooling Capacity BTU/hr

OPTIONAL ACCESSORIES QUANTITY

Multi-Magic Wall Controller

Room Temperature & Humidity Sensor

Ambient Temperature & Humidity Sensor

Duct Temperature & Humidity Sensor

MERV13 Airfilters

STANDARD FEATURES

- Indirect Evaporative Cooling
- Patented high technology CW Indirect Cooling cores.
- Fresh, outside air for better indoor air quality (IAQ).
- No refrigerants or ozone depleting chemicals.
- Quiet and vibration free operation.
- Filtered air with reduced dust, pollens and allergens
- High EER (Energy Efficiency Ratio).
- Horizontal side discharge for conditioned air.
- Top discharge for exhaust air.
- Low maintenance, simple winterization
- Integrated PLC for internal control
- Integrated water management system.
- Removable panels for easy maintenance access.
- Easy to connect power/control wiring.
- BMS/BAS control terminals
- Modbus RS-485 control terminals
- 2x Backward-curved centrifugal supply fans
- 4x Backward-curved centrifugal exhaust fans
- Direct coupled EC fan motors.
- Molded plastic (ASA) water tank.
- Base frame manufactured with galvanized steel.
- Cabinet manufactured from 304 stainless steel.
- Built-in forklift tyne openings for lifting the cooler.
- 1-year limited warranty.
- ETL Listed to UL Standard 507

SUBMITTAL DATA SHEET – CW-80 WITH MULTI-MAGIC CONTROLS

GENERAL

Climate Wizard coolers are characterized by the supply of 100% fresh, cool, outside air with NO additional moisture added, with greatly reduced energy consumption relative to an equivalent refrigerated system performing the same duty.

The coolers comprise of two supply air fans, four exhaust air fans, an indirect heat exchanger pack, integrated water reservoir, pump, and chlorinator system.

CW-80S can be operated in “Supercool” mode producing even colder supply air with added moisture (direct cooling). Supercool coolers have an additional pump and Chillcel® pads.

CABINET

The cabinet is constructed from 304 stainless steel incorporating the motor / fan assemblies, non-corrodible heat exchange cores and other ancillary equipment all supported by a heavy gauge galvanized base frame for structural stability.

Fork lift tine channels are provided within the base frame to facilitate transport and lifting.

Components are effectively treated to ensure corrosion resistance and mechanical fasteners are zinc coated, stainless steel or aluminum.

Connection interface surfaces are provided for the outlet supply air ductwork to be fitted using established industry practices.

FANS & MOTORS

The fans are a multi-blade, centrifugal type with backward curved blades. They have a cast aluminum coated rotor and aluminum impellers which are individually statically and dynamically balanced. The fans are directly mounted to the electric motors.

The electric motors are high efficiency, inverter driven and responsive to 0-10V control signals to implement speed control that delivers optimum efficiency at lower speed operation.

HEAT EXCHANGE CORE

The heat exchange cores are designed to facilitate heat exchange between the wet air passages and the dry air passages such that high efficiency heat transfer takes place without any additional moisture.

They are designed to provide long life and consistent, long term high efficiency.

Supercool models are fitted with additional Chillcel® fabricated, honeycomb direct cooling pads.

WATER MANAGEMENT SYSTEM

The water supply connection is a ¾” fitting that connects directly to the internally mounted solenoid valve.

Water is held in an internal reservoir manufactured from molded polymer to ensure durability and corrosion resistance.

Heat exchange core saturation is achieved through internally mounted pumps delivering water to a specially designed non-clog water distribution system guaranteeing continuous uniform flow.

The wet components of each pump are manufactured from stainless steel and the pumps are driven by a 3-phase industrial, fully enclosed fan cooled electric motor with thermal overload protection. Easily cleanable in line strainers are provided for both the incoming water supply and the water distribution system.

An electronic water management system controls the maximum salinity level and chlorination of the reservoir water through continuous monitoring and replenishment.

The reservoir is drained by an electric drain valve that responds to the water management control system. The design of the reservoir ensures that no water remains after draining.

AIR FILTERS

Intake air is filtered through aluminum framed, washable pleated filters protected by intake louvers to minimize intrusion of rain.

APPROVALS

CW-80 coolers are ETL Listed to UL Standard 507

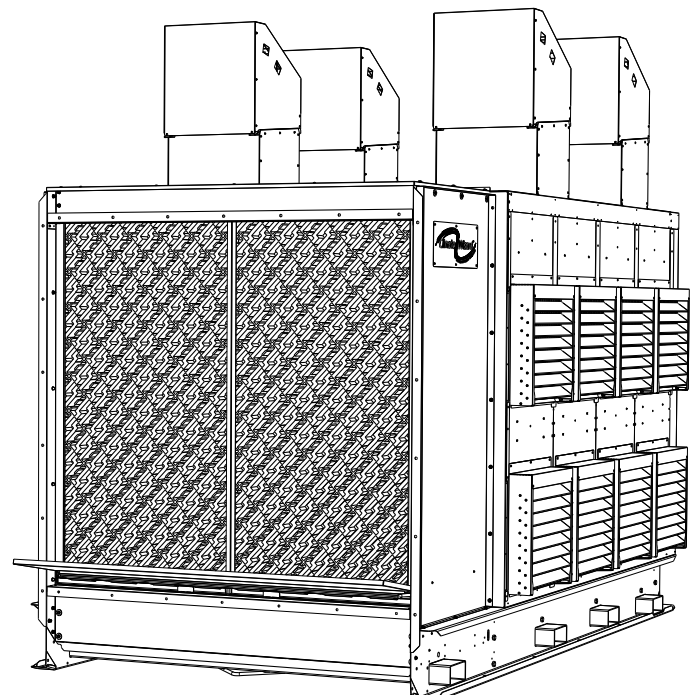

SUBMITTAL DATA SHEET – CW-80 WITH MULTI-MAGIC CONTROLS

TOP

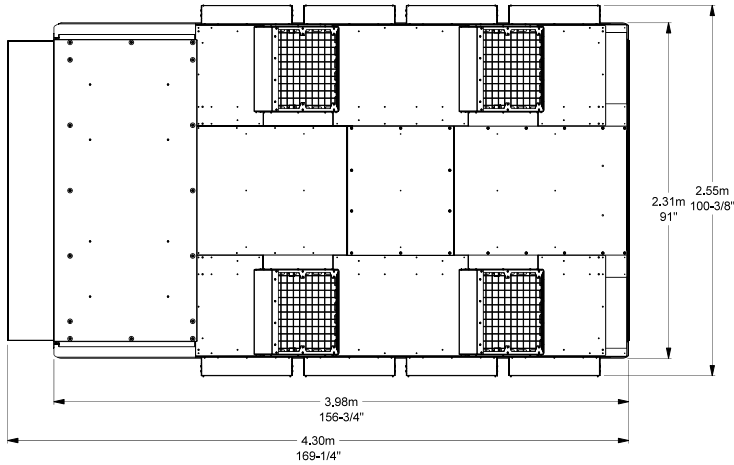

BACK

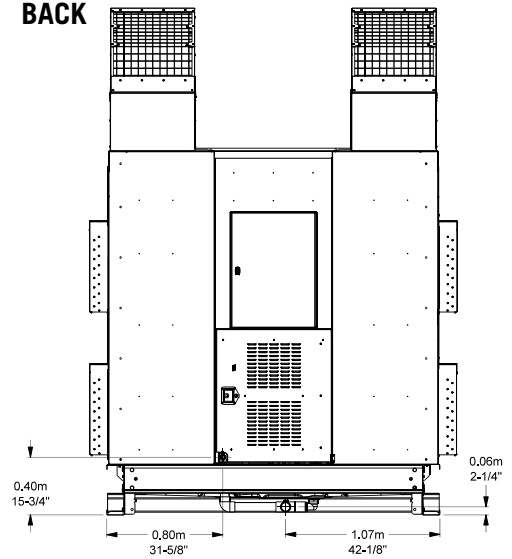

SIDE

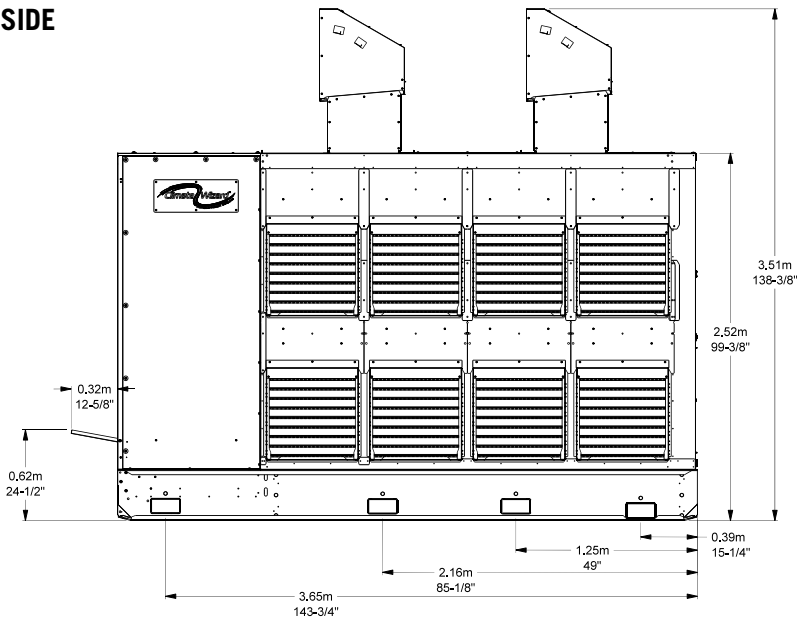

FRONT

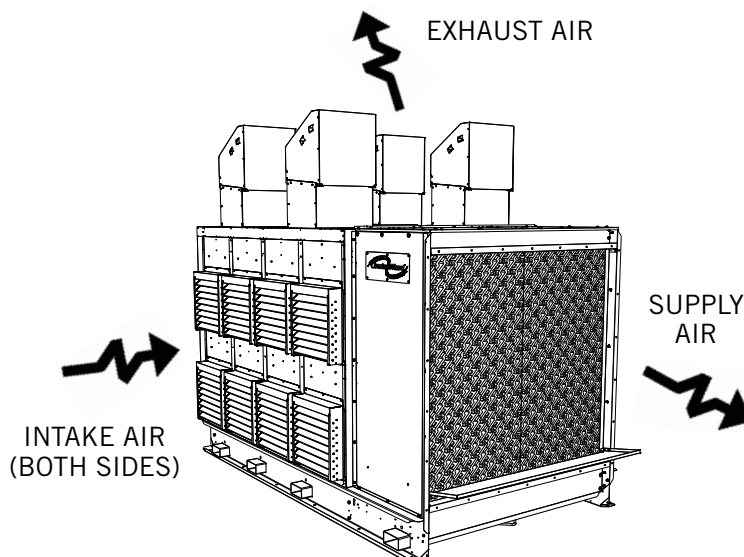
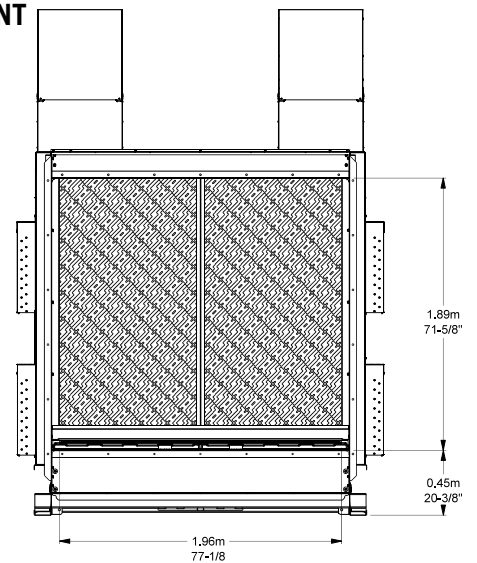

NOTE: Installers must allow adequate access to and around the cooler for Maintenance.

Provision must be made for access to power, control, water supplies and drains.

Refer to the Installation Manual for full details.

SUBMITTAL DATA SHEET – CW-80 WITH MULTI-MAGIC CONTROLS

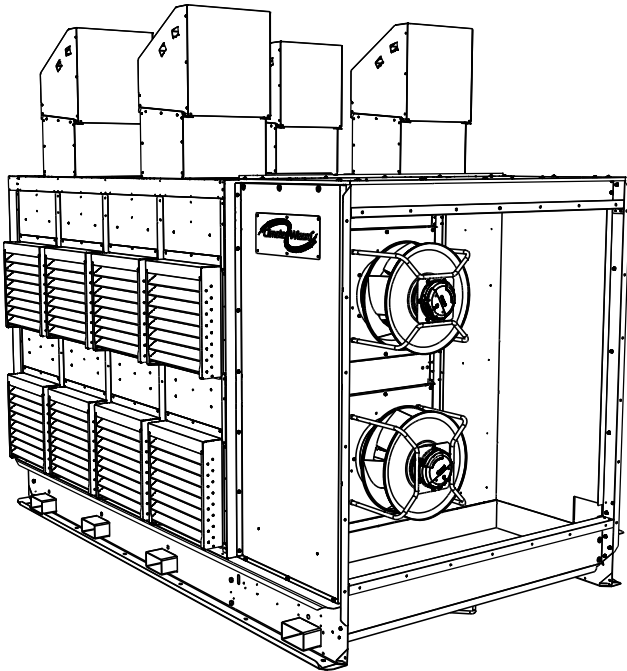

CW-80 IEC STANDARD CAPACITY FANS

- Primary Indirect Evaporative Cooling Stage
- No added Moisture

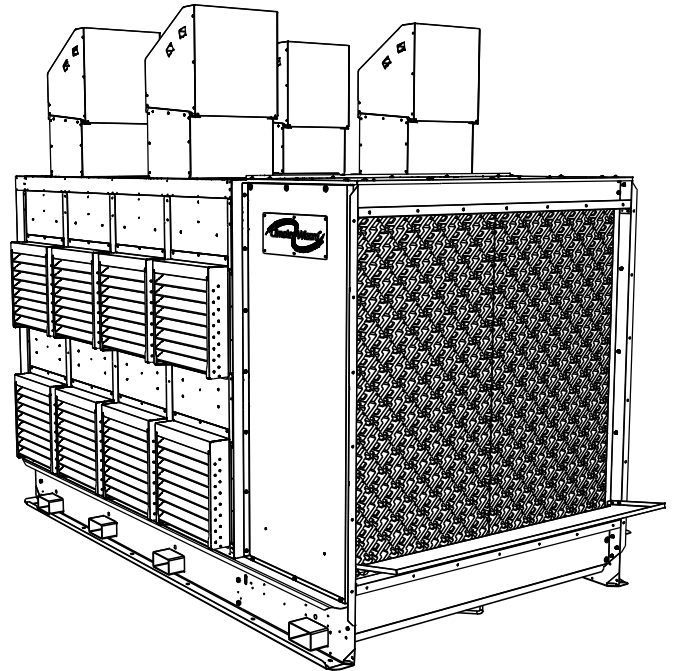

CW-80 SUPERCOOL STANDARD CAPACITY FANS

- Primary Indirect Evaporative Cooling Stage
- Secondary Direct Evaporative Cooling Stage
- Highest Energy Efficiency

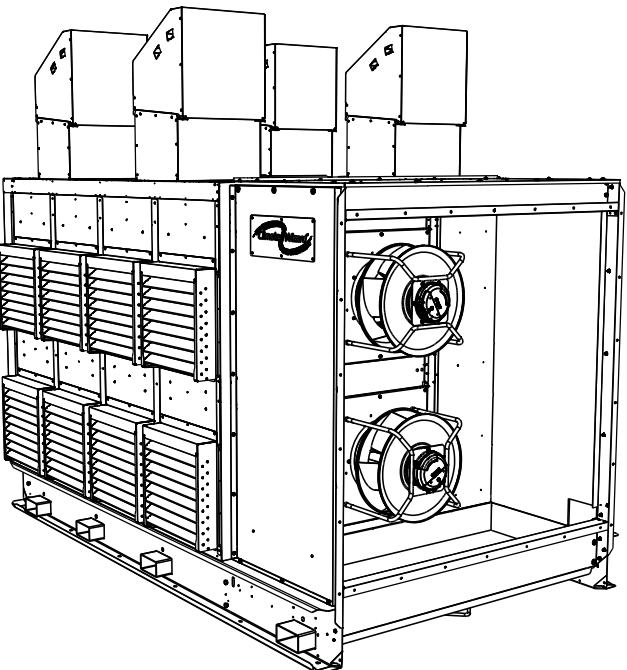

CW-80 IEC HIGH CAPACITY FANS

- Primary Indirect Evaporative Cooling Stage
- No added Moisture
- Highest External Static Pressure Capacity

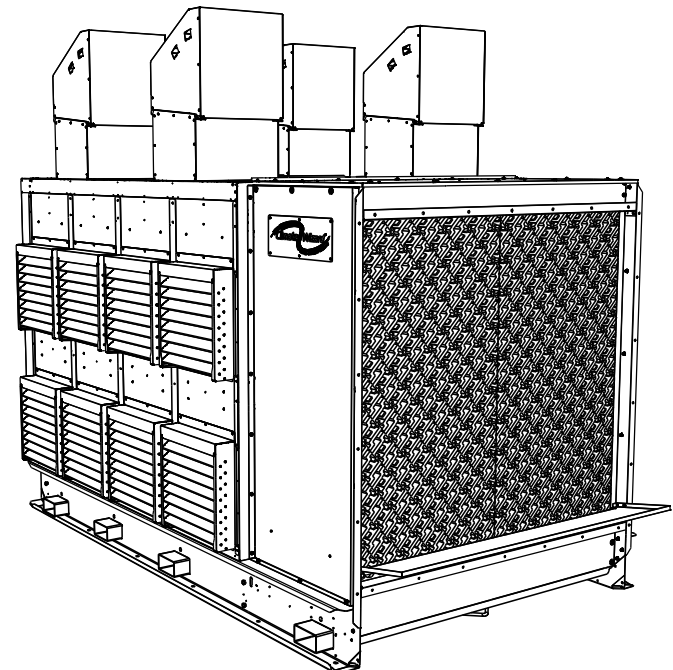

CW-80 SUPERCOOL HIGH CAPACITY FANS

- Primary Indirect Evaporative Cooling Stage
- Secondary Direct Evaporative Cooling Stage
- Highest Cooling Capacity

SUBMITTAL DATA SHEET – CW-80 WITH MULTI-MAGIC CONTROLS

- CW-80 IEC Standard Capacity — CW-80 IEC High Capacity
- - - CW-80 SUPERCOOL Standard Capacity •••• CW-80 SUPERCOOL High Capacity

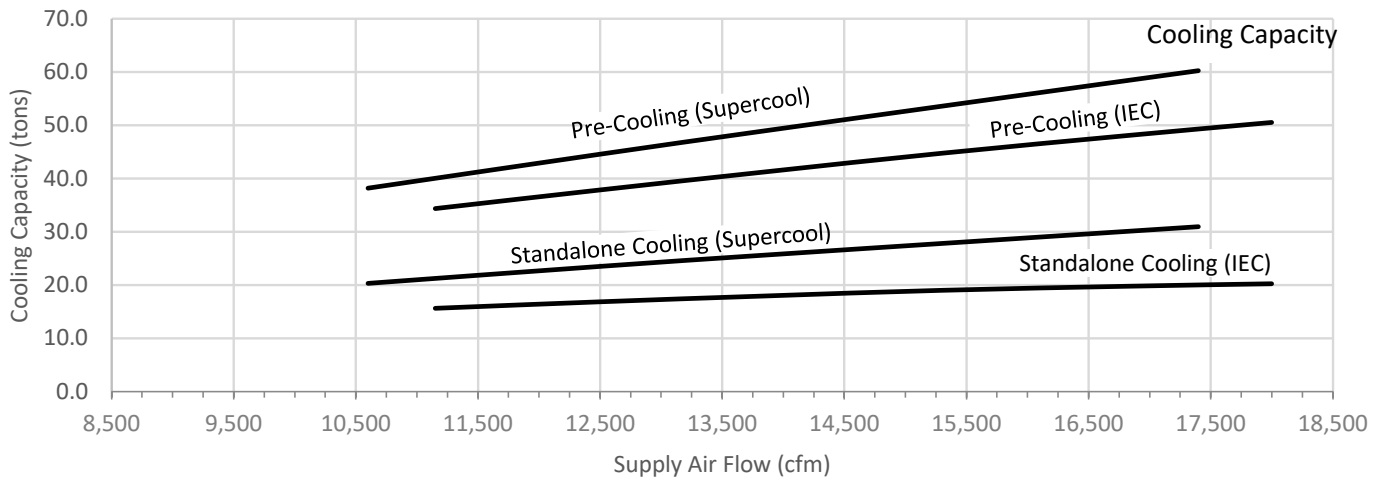
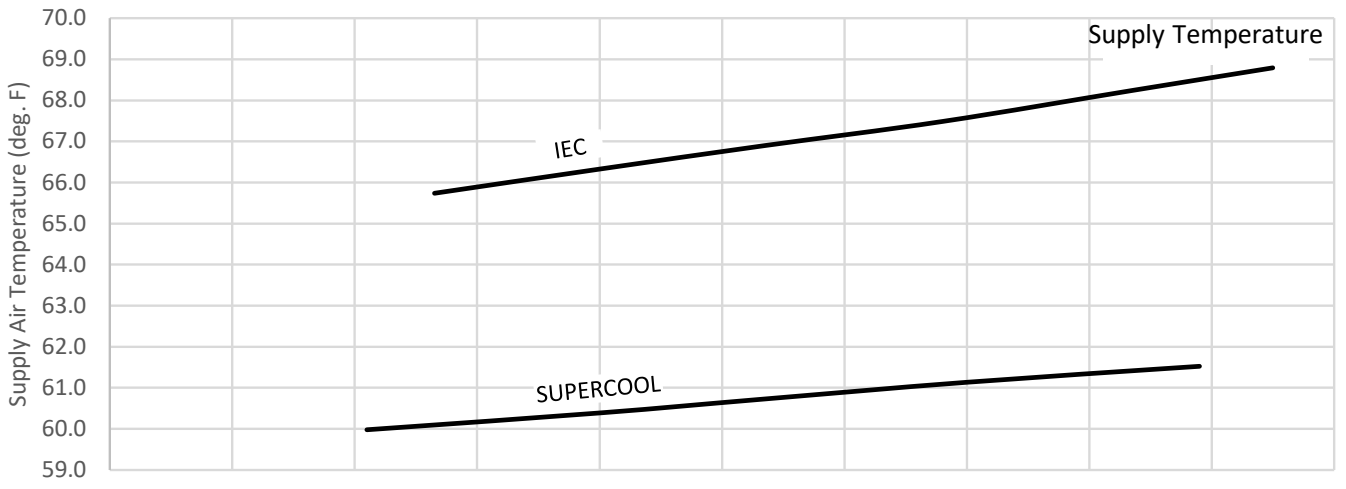
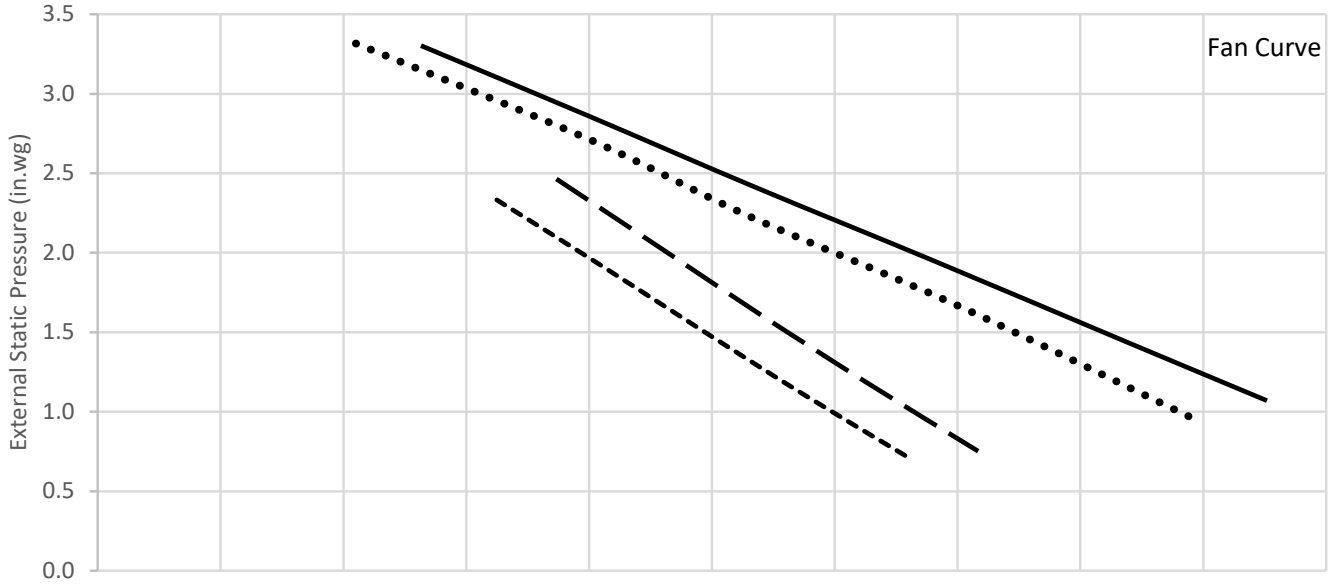

SUBMITTAL DATA SHEET – CW-80 WITH MULTI-MAGIC CONTROLS

MODEL:			CW-80 IEC STANDARD CAPACITY FANS	CW-80 SUPERCool STANDARD CAPACITY FANS
SERVICES	Electrical	Voltage	440-480 V / 3~ / 60Hz	440-480 V / 3~ / 60Hz
		FLA	23 A	24 A
		MCA	24 A	25 A
		MOPD	25 A	25 A
		Input Power	12.5 kW	12.5 kW
	Water	Supply	5.5 GPM MINIMUM 6.5 GPM RECOMMENDED @ 12 – 145 PSI	5.5 GPM MINIMUM 6.5 GPM RECOMMENDED @ 12 – 145 PSI
		Max Temperature	105 °F	105 °F
		Inlet	3/4" Male BSP	3/4" Male BSP
		Drain	2" Flexible Coupling	2" Flexible Coupling
		Drain Flow Rate	10.5 GPM	10.5 GPM
	Duct Connections	Supply Air	Side Discharge 74 x 91"	Side Discharge 74 x 91"
Exhaust Air		4x Top Discharge Vents	4x Top Discharge Vents	
ENVIRONMENT	Maximum Inlet Air Temperature		120 °F	120 °F
AIR SYSTEMS	Supply Air Fan/Motor	Fan	2x 560mm Centrifugal	2x 560mm Centrifugal
		Motor	3.5 kW	3.5 kW
		Control	Variable Speed, ECM, 0-10V	Variable Speed, ECM, 0-10V
		Maximum Speed	1750 rpm	1750 rpm
	Exhaust Air Fan/Motor	Fan	4x 355mm Centrifugal	4x 355mm Centrifugal
		Motor	1.7 kW	1.7 kW
		Control	Variable Speed, ECM, 0-10V	Variable Speed, ECM, 0-10V
		Maximum Speed	2600 rpm	2600 rpm
	Air Filters	Inlet	16x MERV 8 Washable 25" x 25" x 2"	16x MERV 8 Washable 25" x 25" x 2"
	HEAT EXCHANGERS	Indirect Evaporative		16 Cores
Direct Evaporative		NONE	2 Chillcel Pads	
WATER SYSTEMS	Tank (Reservoir) Capacity		48 Gal	48 Gal
	Inlet Valve		24 VAC Solenoid Valve	24 VAC Solenoid Valve
	Pump Indirect Heat Exchangers		1x 20 GPM @ 81 ft Head 440-480V / 3~ / 50-60 Hz Input Power 0.75 kW	1x 20 GPM @ 81 ft Head 440-480V / 3~ / 50-60 Hz Input Power 0.75 kW
	Pump Direct Heat Exchangers		NONE	1x 10 GPM @ 45 ft Head 440-480V / 3~ / 50-60 Hz Input Power 0.25 kW
	Salinity Management		Conductivity Probe	Conductivity Probe
	Chlorinator		230V, 50-60Hz	230V, 50-60Hz
	Drain Valve		12 VAC Vertical	12 VAC Vertical
DIMENSIONS	Shipping	Note: Exhaust Fans/ Motors, Weatherseals & Filters shipped loose.	157" Long, 91" Wide, 101" High	157" Long, 91" Wide, 101" High
	Operating		157" Long, 101" Wide, 139" High	157" Long, 101" Wide, 139" High
WEIGHT	Shipping	exc. Loose items	4,400 lb	4,650 lb
	Operating	inc. Water & Extras	5,950 lb	6,300 lb

SUBMITTAL DATA SHEET – CW-80 WITH MULTI-MAGIC CONTROLS

CW-80 IEC STANDARD CAPACITY FANS

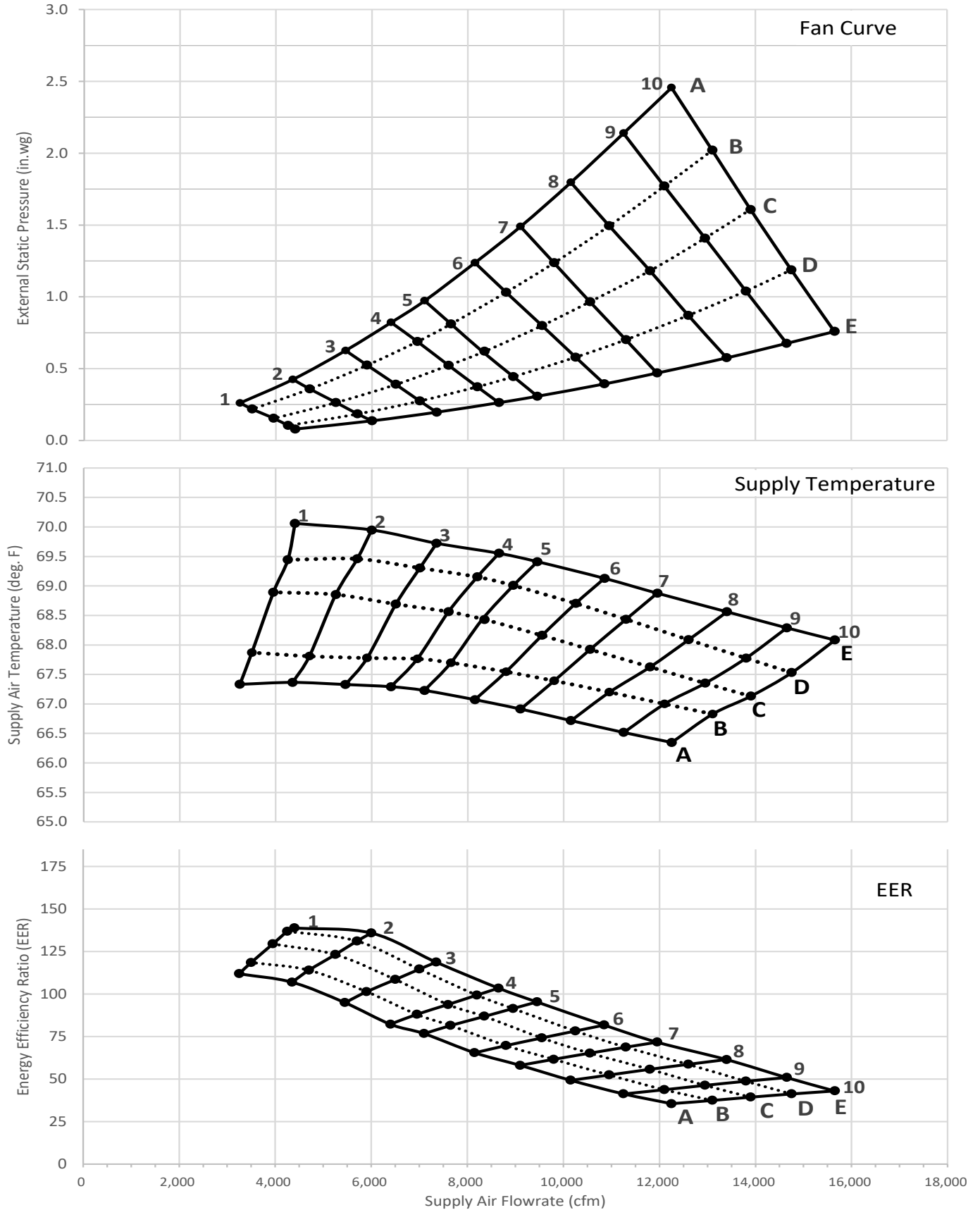

SUBMITTAL DATA SHEET – CW-80 WITH MULTI-MAGIC CONTROLS

CW-80 SUPERCOOL STANDARD CAPACITY FANS

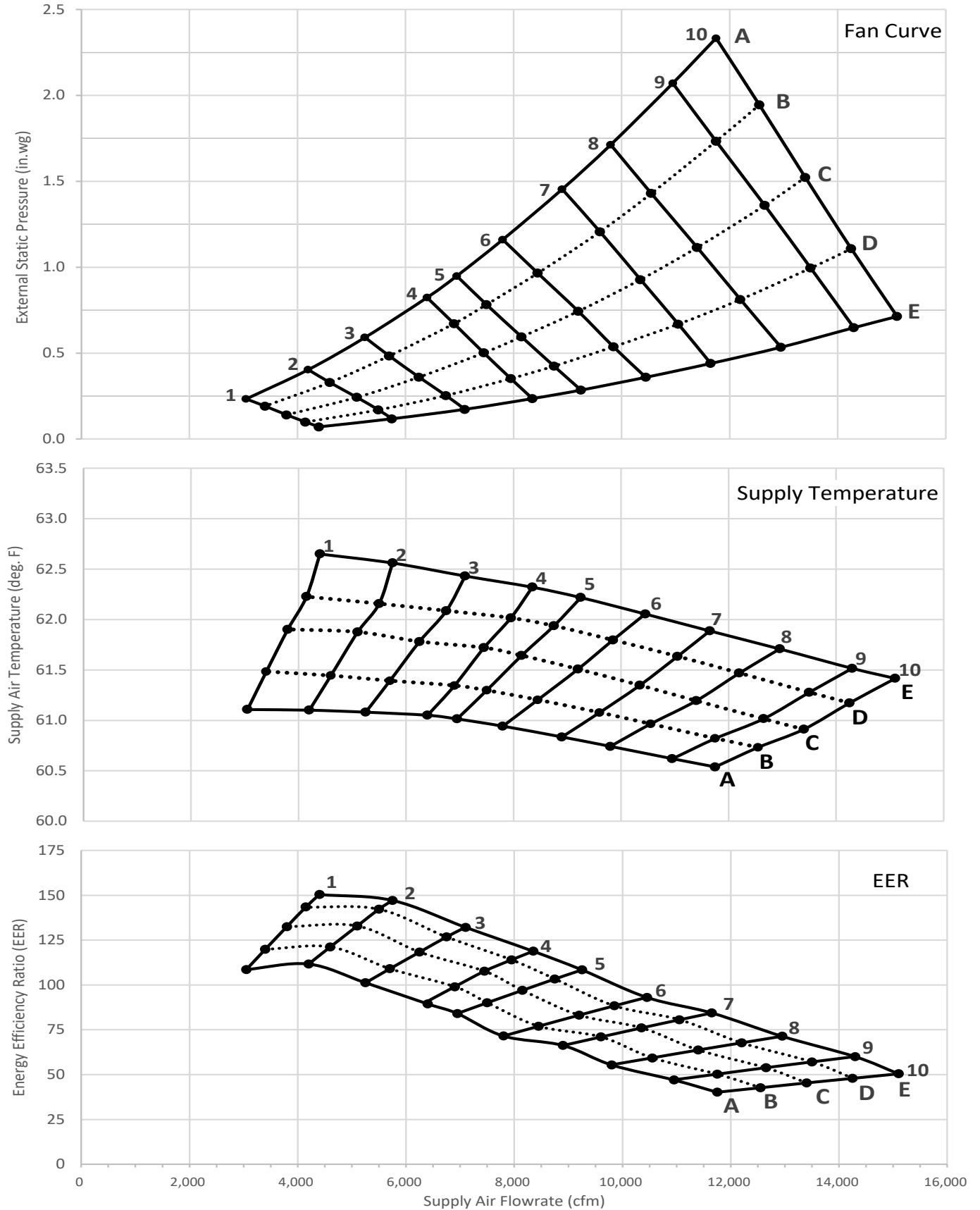

SUBMITTAL DATA SHEET – CW-80 WITH MULTI-MAGIC CONTROLS

CW-80 IEC STANDARD CAPACITY SPEED 10 PERFORMANCE SUMMARY*					
	A	B	C	D	E
EXTERNAL STATIC PRESSURE (IN. WG)	2.5	2.0	1.6	1.2	0.8
SUPPLY AIR FLOWRATE (CFM)	12,250	13,100	13,900	14,750	15,650
IEC SUPPLY TEMPERATURE (°F)	66.3	66.8	67.1	67.5	68.1
STANDALONE COOLING CAPACITY (BTU/HR)	197,800	204,800	212,700	219,300	223,400
PRE-COOLING CAPACITY (BTU/HR)	445,200	469,300	493,400	517,200	539,500
INPUT POWER (KW)	12.5	12.5	12.5	12.5	12.5
STANDALONE EER	16	16	17	18	18
PRE-COOLING EER	38	39	41	43	43
WATER CONSUMPTION (GPH)	63	65	66	67	69

CW-80 SUPERCOOL STANDARD CAPACITY SPEED 10 PERFORMANCE SUMMARY*					
	A	B	C	D	E
EXTERNAL STATIC PRESSURE (IN. WG)	2.3	1.9	1.5	1.1	0.7
SUPPLY AIR FLOWRATE (CFM)	11,750	12,550	13,400	14,250	15,100
IEC SUPPLY TEMPERATURE (°F)	66.6	67.0	67.4	67.8	68.2
SUPERCOOL SUPPLY TEMPERATURE (°F)	60.5	60.7	60.9	61.2	61.4
STANDALONE COOLING CAPACITY (BTU/HR)	263,500	278,800	295,100	309,800	324,300
PRE-COOLING CAPACITY (BTU/HR)	500,800	532,200	565,700	597,500	629,200
INPUT POWER (KW)	12.5	12.5	12.5	12.5	12.5
STANDALONE EER	21	22	24	25	26
PRE-COOLING EER	40	43	45	48	50
WATER CONSUMPTION (GPH)	67	70	73	75	78

* Leaving Air Temperatures, Cooling Capacities and Water Consumption valid at design condition of: 100 °F dry-bulb, 70 °F wet-bulb, 81.3 °F relief temperatures

INPUT POWER (KW)					
SPEED	CW-80 IEC STANDARD CAPACITY	CW-80 SUPERCOOL STANDARD CAPACITY	SPEED	CW-80 IEC STANDARD CAPACITY	CW-80 SUPERCOOL STANDARD CAPACITY
10	12.5	12.5	5	3.3	3.5
9	9.9	9.9	4	2.8	2.9
8	7.4	7.5	3	2.0	2.2
7	5.6	5.7	2	1.4	1.6
6	4.4	4.6	1	1.0	1.2

SUBMITTAL DATA SHEET – CW-80 WITH MULTI-MAGIC CONTROLS

MODEL:			CW-80 IEC HIGH CAPACITY FANS	CW-80 SUPERCOOL HIGH CAPACITY FANS
SERVICES	Electrical	Voltage	440-480 V / 3~ / 60Hz	440-480 V / 3~ / 60Hz
		FLA	25 A	26 A
		MCA	27 A	28 A
		MOPD	30 A	30 A
		Input Power	14.5 kW	14.5 kW
	Water	Supply	5.5 GPM MINIMUM 6.5 GPM RECOMMENDED @ 12 – 145 PSI	5.5 GPM MINIMUM 6.5 GPM RECOMMENDED @ 12 – 145 PSI
		Max Temperature	105 °F	105 °F
		Inlet	3/4" Male BSP	3/4" Male BSP
		Drain	2" Flexible Coupling	2" Flexible Coupling
		Drain Flow Rate	10.5 GPM	10.5 GPM
	Duct Connections	Supply Air	Side Discharge 74 x 91"	Side Discharge 74 x 91"
Exhaust Air		4x Top Discharge Vents	4x Top Discharge Vents	
ENVIRONMENT	Maximum Inlet Air Temperature		120 °F	120 °F
AIR SYSTEMS	Supply Air Fan/Motor	Fan	2x 560mm Centrifugal	2x 560mm Centrifugal
		Motor	4.25 kW	4.25 kW
		Control	Variable Speed, ECM, 0-10V	Variable Speed, ECM, 0-10V
		Maximum Speed	1750 rpm	1750 rpm
	Exhaust Air Fan/Motor	Fan	4x 355mm Centrifugal	4x 355mm Centrifugal
		Motor	1.7 kW	1.7 kW
		Control	Variable Speed, ECM, 0-10V	Variable Speed, ECM, 0-10V
		Maximum Speed	2600 rpm	2600 rpm
	Air Filters	Inlet	16x MERV 8 Washable 25" x 25" x 2"	16x MERV 8 Washable 25" x 25" x 2"
	HEAT EXCHANGERS	Indirect Evaporative		16 Cores
Direct Evaporative		NONE	2 Chillcel Pads	
WATER SYSTEMS	Tank (Reservoir) Capacity		48 Gal	48 Gal
	Inlet Valve		24 VAC Solenoid Valve	24 VAC Solenoid Valve
	Pump Indirect Heat Exchangers		1x 20 GPM @ 81 ft Head 440-480V / 3~ / 50-60 Hz Input Power 0.75 kW	1x 20 GPM @ 81 ft Head 440-480V / 3~ / 50-60 Hz Input Power 0.75 kW
	Pump Direct Heat Exchangers		NONE	1x 10 GPM @ 45 ft Head 440-480V / 3~ / 50-60 Hz Input Power 0.25 kW
	Salinity Management		Conductivity Probe	Conductivity Probe
	Chlorinator		230V, 50-60Hz	230V, 50-60Hz
	Drain Valve		12 VAC Vertical	12 VAC Vertical
DIMENSIONS	Shipping	Note: Exhaust Fans/ Motors, Weatherseals & Filters shipped loose.	157" Long, 91" Wide, 101" High	157" Long, 91" Wide, 101" High
	Operating		157" Long, 101" Wide, 139" High	157" Long, 101" Wide, 139" High
WEIGHT	Shipping	exc. Loose items	4,400 lb	4,650 lb
	Operating	inc. Water & Extras	5,950 lb	6,300 lb

SUBMITTAL DATA SHEET – CW-80 WITH MULTI-MAGIC CONTROLS

CW-80 IEC HIGH CAPACITY FANS

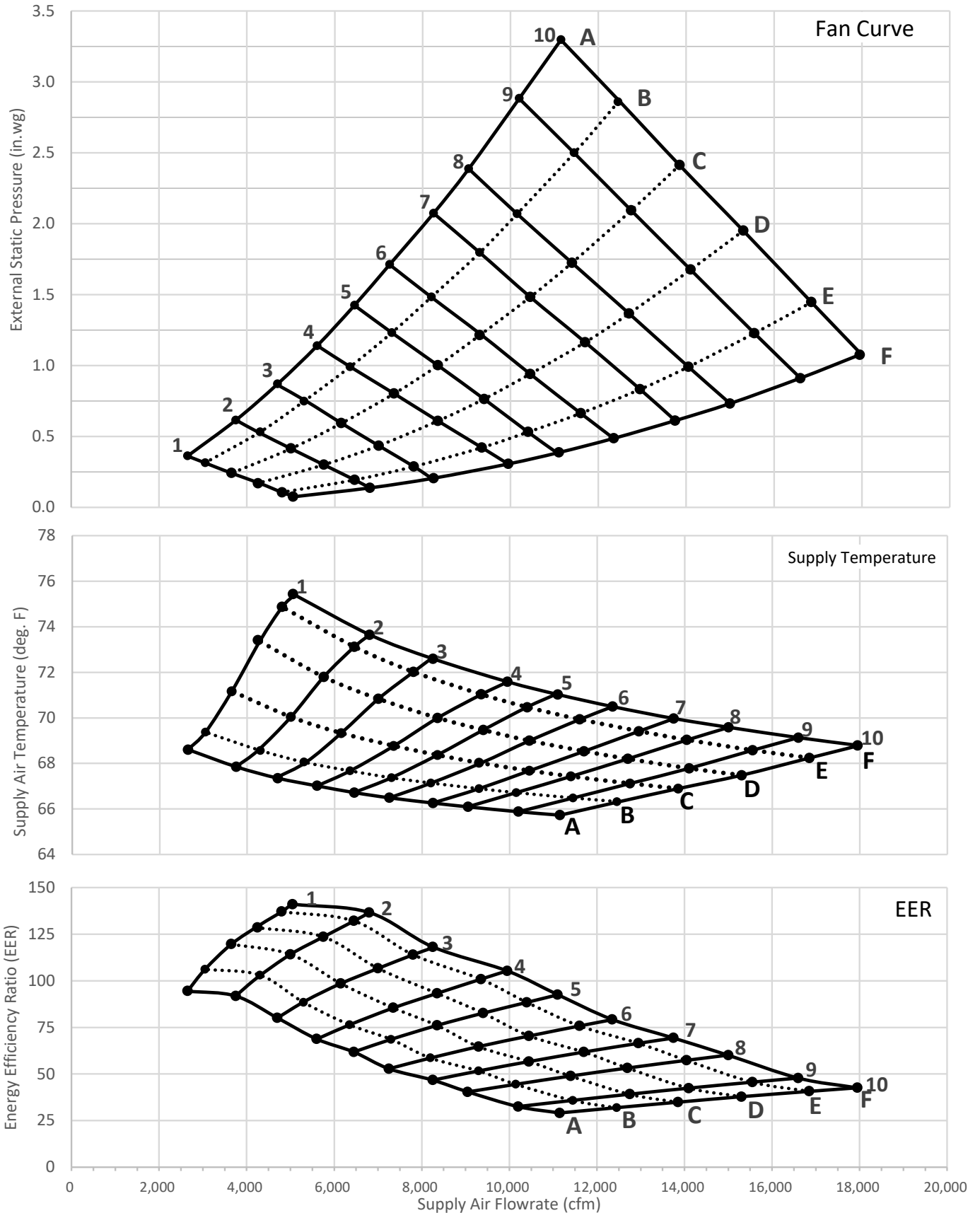

SUBMITTAL DATA SHEET – CW-80 WITH MULTI-MAGIC CONTROLS

CW-80 SUPERCOOL HIGH CAPACITY FANS

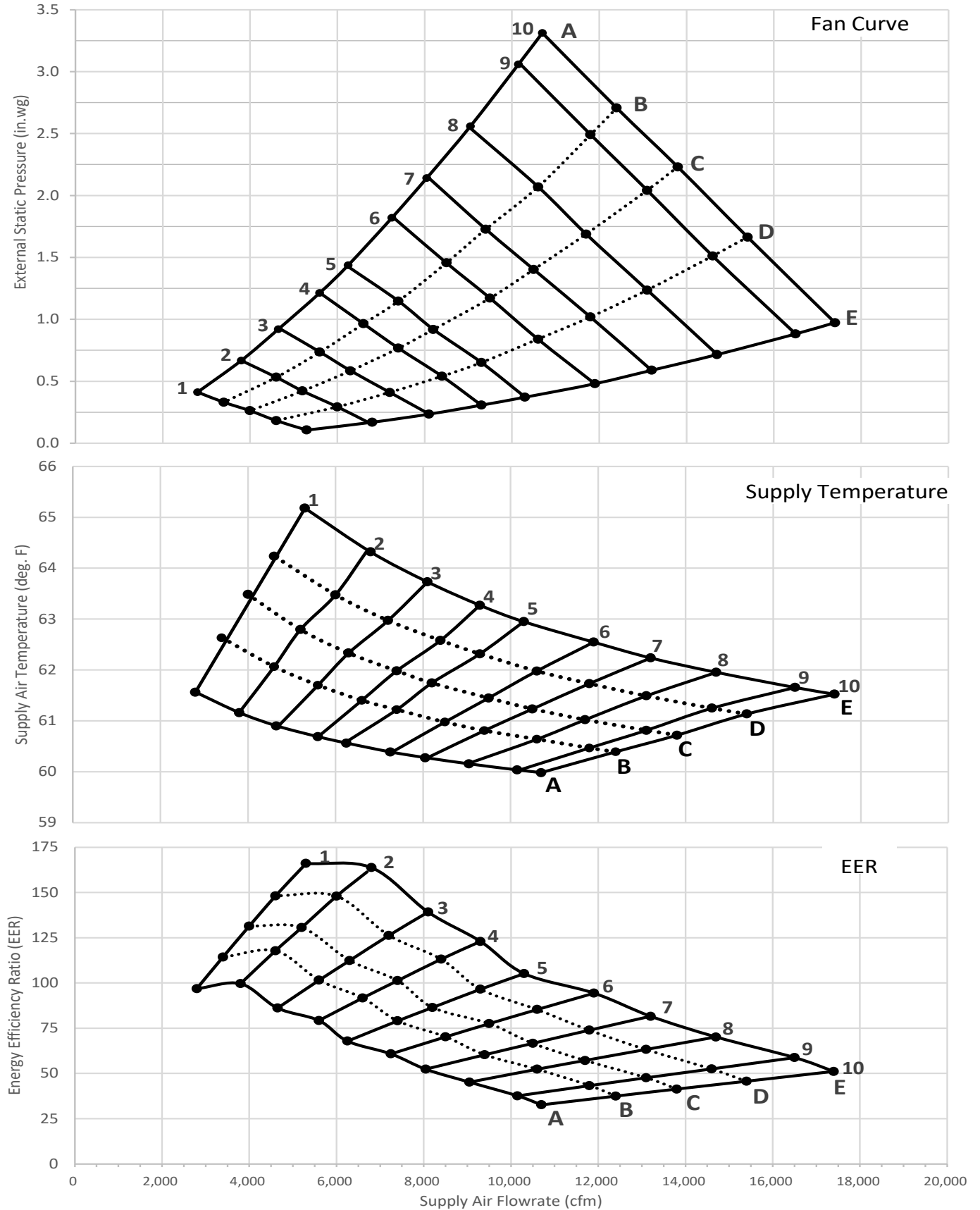

SUBMITTAL DATA SHEET – CW-80 WITH MULTI-MAGIC CONTROLS

CW-80 IEC HIGH CAPACITY SPEED 10 PERFORMANCE SUMMARY*						
	A	B	C	D	E	F
EXTERNAL STATIC PRESSURE (IN. WG)	3.3	2.9	2.4	2.0	1.4	1.1
SUPPLY AIR FLOWRATE (CFM)	11,150	12,500	13,850	15,300	16,850	18,000
IEC SUPPLY TEMPERATURE (°F)	65.7	66.3	66.9	67.5	68.2	68.8
STANDALONE COOLING CAPACITY (BTU/HR)	187,400	202,200	215,400	228,300	237,700	243,200
PRE-COOLING CAPACITY (BTU/HR)	412,600	454,600	495,200	537,300	578,000	606,700
INPUT POWER (KW)	14.2	14.2	14.2	14.2	14.2	14.2
STANDALONE EER	13	14	15	16	17	17
PRE-COOLING EER	29	32	35	38	41	43
WATER CONSUMPTION (GPH)	62	65	67	70	71	73

CW-80 SUPERCOOL HIGH CAPACITY SPEED 10 PERFORMANCE SUMMARY*					
	A	B	C	D	E
EXTERNAL STATIC PRESSURE (IN. WG)	3.3	2.7	2.2	1.7	1.0
SUPPLY AIR FLOWRATE (CFM)	10,600	12,500	13,800	15,500	17,400
IEC SUPPLY TEMPERATURE (°F)	65.5	66.3	66.9	67.7	68.4
SUPERCOOL SUPPLY TEMPERATURE (°F)	60.0	60.4	60.7	61.1	61.5
STANDALONE COOLING CAPACITY (BTU/HR)	244,100	282,300	306,800	337,500	371,600
PRE-COOLING CAPACITY (BTU/HR)	458,100	534,700	585,500	650,600	723,000
INPUT POWER (KW)	14.2	14.2	14.2	14.2	14.2
STANDALONE EER	17	20	22	24	26
PRE-COOLING EER	32	38	41	46	51
WATER CONSUMPTION (GPH)	70	74	78	82	88

* Leaving Air Temperatures, Cooling Capacities and Water Consumption valid at design condition of: 100 °F dry-bulb, 70 °F wet-bulb, 81.3 °F relief temperatures

INPUT POWER (KW)					
SPEED	CW-80 IEC HIGH CAPACITY	CW-80 SUPERCOOL HIGH CAPACITY	SPEED	CW-80 IEC HIGH CAPACITY	CW-80 SUPERCOOL HIGH CAPACITY
10	14.2	14.2	5	3.8	3.9
9	11.6	11.6	4	2.9	3.0
8	8.2	8.6	3	2.1	2.3
7	6.4	6.6	2	1.4	1.6
6	5.0	5.1	1	1.0	1.2

SUBMITTAL DATA SHEET – CW-80 WITH MULTI-MAGIC CONTROLS

OPTIONS, FEATURES & ACCESSORIES

Multi-Magic coolers are supplied with a series of interface terminals inside the electrical enclosure for use with additional accessories.

ITEM	ID	TYPE
MODBUS	+	RS-485 MODBUS Communication for Wall Controller or 3rd Party Master
	-	
	GND	
POWER SUPPLY	24Vdc	DC Power Supply for Wall Controller, Sensors or BMS
	0Vdc	
MULTI-MAGIC SENSORS (sold separately)	RM TEMP	Room Temperature 0-10V
	RM RH	Room Humidity 0-10V
	AMB TEMP	Ambient Temperature 0-10V
	AMB RH	Ambient Humidity 0-10V
	SUP TEMP	Duct Temperature 0-10V
FAN STATUS	FAN STS	Fan Run Output. Relay Output Dry Contact, Adjustable Timer
	FAN COM	
FIRE	FIRE	Fire Terminals. Bridge to Run.
	FIRE	

Multi-Magic coolers can be controlled via 4 different methods.

OPTION 1: BUILDING MANAGEMENT SYSTEM (BMS)

Multi-Magic coolers are supplied with a series of low voltage BMS Interface Terminals to allow external devices, such as 3rd party controllers, to control the basic functions of the cooler.

ITEM	ID	TYPE
BMS	IEC	Digital Input Dry Contact
	DEC	Digital Input Dry Contact
	SPD	Speed: Analogue Input 0-10Vdc
	ERR	Error: Relay Output Dry Contact. Configurable NO/NC
	GND	GND

OPTION 2: MULTI-MAGIC WALL CONTROLLER

(sold separately)

- MODBUS RS-485 to control up to 15 Devices
- Inbuilt Temperature & RH Sensors
- Manual or Automatic Speed Control
- Thermostatic Speed Control
- Supercool Humidity Setpoint
- 7-Day Program
- Room Sensor Averaging
- Ambient Condition Monitoring
- Min & Max Fan Speed Limits
- Screen Security Lock
- Auto-Restart Function
- Device Fault History
- English, Spanish, French, Italian, Portuguese



OPTION 3: RS-485 MODBUS PRIMARY

Multi-Magic coolers can be controlled via a 3rd Party RS-485 Modbus Primary. Modbus Registers are available for controlling and monitoring the basic functions of the connected coolers.

REGISTER	TYPE	DETAILS	
COMMANDS			
9200	UINT	Bit 0	IEC Enable
		Bit 1	DEC Enable
		Bit 2	Fault Reset
		Bit 3	Manual Drain
9201	UINT	0-1000	Supply Fan Speed (0-100%)
STATUS			
9205	UINT	Bit 0	Fault State
		Bit 1	Low Probe WET
		Bit 2	High Probe WET
		Bit 3	Inlet Solenoid Valve OPEN
		Bit 4	Drain Valve OPEN
		Bit 5	Indirect Pump RUNNING
		Bit 6	Direct Pump RUNNING
		Bit 7	Chlorinator RUNNING
9206	UINT	0-1000	Supply Fan Speed (0-100%)
9207	UINT	0-6615	Water Salinity Level
9208	UINT	0-100	Chlorinator Output (%)
9209	UINT		Fault Code
9210	INT	-400 - 700	Ambient Temperature
9211	INT	0 - 1000	Ambient Relative Humidity
9212	INT	0 - 500	Room Temperature
9213	INT	0 - 1000	Room Relative Humidity

OPTION 4: BACNET MS/TP OR BACNET IP

Multi-Magic coolers can be controlled via a 3rd Party BACnet Controller, either via MS/TP or IP protocols. BACnet objects are available for controlling and monitoring the basic functions of the connected coolers.

OBJECT	DETAILS
COMMANDS	
CMD_IEC	IEC Enable
CMD_DEC	DEC Enable
CMD_Spd	0 to 10 Fan Speed
CMD_Drain	Manual Drain
BCN_CMD_ON_OFF	Cooler Run
CMD_FaultReset	Reset Fault Codes
STATUS	
STSIEC	IEC Pump RUNNING
STSDEC	DEC Pump RUNNING
STSError	Fault
STSLowProbe	Low Probe WET
STSHighProbe	High Probe WET
STSSolenoid	Inlet Solenoid OPEN
STSDrain	Drain Valve OPEN
STSchlorinator	Chlorinator RUNNING
STSSupplyFSpd	Supply Fan Speed Range 0 to 10
STSSalinity	Water Salinity Level (uS/cm)
STSchIPWM	Chlorinator PWM %
STSFaultCode	Fault Code.
STSAmbientTemp	Ambient Sensor Temperature -40 to 158°F
STSAmbientRH	Ambient Sensor RH, Range 0 to 100 %
STSRoomTemp	Room Sensor Temperature 32 to 212°F
STSRoomRH	Room Sensor RH, Range 0 to 100 %

SUBMITTAL DATA SHEET – CW-80 WITH MULTI-MAGIC CONTROLS

TEMPERATURE & RELATIVE HUMIDITY SENSORS

(sold separately)

For all sensors:

Operating Voltage DC 24V

Signal Output DC 0...10 V

Accuracy at 73°F and 50% r.h.

Temperature: $\pm 0.3K$

Relative Humidity: $\pm 3\%$ r.h.

Each CW-80 cooler had dedicated inputs for one each of the following optional sensors.

All sensor value are readable by Building Management Systems (Low Voltage, Modbus or BACnet).

ROOM SENSOR

Temperature Range
+32...+122°F

Relative Humidity Range
0...100% r.h.

IP30

When used in conjunction with the Multi-Magic Wall Controller:

- Allows the Wall Controller to be located safely away from the conditioned space. Wall Controller sensor values are disabled and only Room Sensor used for setpoint control.
- Multiple Room Sensor values from multiple coolers be average together to provide an overall temperature and relative humidity ales for larger spaces.



DUCT SENSOR

Temperature Range
+32...+122°F

Relative Humidity Range
0...100% r.h.

IP54

Probe length inside duct min.
3.5", max 6"

- Can be used by Building Management Systems (Low Voltage, Modbus or BACnet) to monitor cooler supply air conditions.



AMBIENT SENSOR

Temperature Range
-40...+158°F

Relative Humidity Range
0...100% r.h.

Radiation Shield
IP65

When used in conjunction with the Multi-Magic Wall Controller:

- Ambient Condition Monitoring mode uses advanced formulas to calculate a predicted supply temperature. Coolers are disabled if the predicted supply temperature is greater than the current room temperature.
- Particularly suitable for applications which require room temperatures less than 68 °F

