

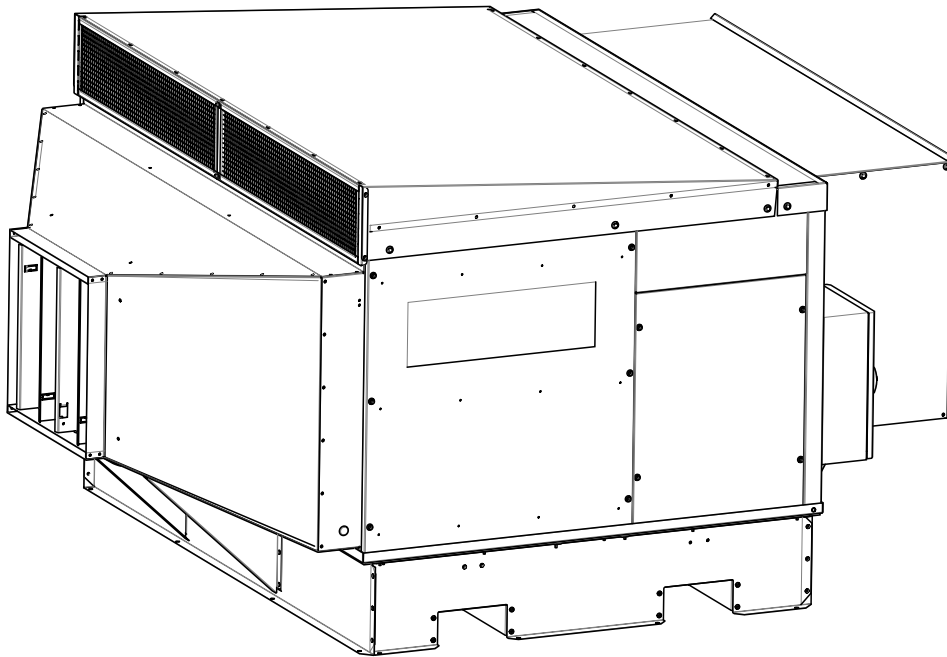

INSTALLATION & OPERATION MANUAL

INDIRECT EVAPORATIVE COOLER

CW-H10, CW-H15, CW-H15S, CW-H15S Plus



(English) (CW-H15)



Original English Instructions

TABLE OF CONTENTS

IMPORTANT SAFETY INSTRUCTIONS

For Europe	4
For Australia, New Zealand & other Non-European Countries	4
Risk Assessment	5
Installer and Maintenance Contractors	5
Some Points to Consider	5
Other Important Requirements	5

MAINTENANCE NOTE

5

COOLER VIEWS

CW-H10	6
CW-H15	7

COOLER EXPLODED VIEW

8

COOLER SPECIFICATIONS

9

TECHNICAL SPECIFICATIONS - METRIC MODELS

9

TECHNICAL SPECIFICATIONS - IMPERIAL MODELS

10

COOLER CONTENTS

Cooler Installation Components	11
Optional Components	11

INSTALLATION

Cooler Location	12
Mounting/Support	12
Unpacking the Cooler	12
Moving the Cooler	12
Lifting the Cooler	12
Vibration Isolation	12
Drip-tray	12
Supply Air Duct Connections	12
Exhaust Transition Assembly	13
Exhaust Duct Connection Requirements	13
Inlet Air Filter Assembly or Safety Grille	14
Inlet Air Filter Cowling Assembly	15
Water Supply Installation	16
Water Supply Filtration	16
Water Hammer	16
Water Drain Installation	16
Electrical Supply Installation (Australia, Europe - 3PH 380-415V)	17
Electrical Supply Installation (USA 3PH, 380 - 480V)	18
Electrical Supply Installation (USA 3PH, 200 - 240V)	19
Electrical Supply Installation (USA 1PH, 200 - 240V)	20
Climate Wizard Supercool Installation	21
Relay Control Method 1: Switch	21
Relay Control Method 2: BMS	21
Relay Control Method 3: Always Run	21

CONTROL SCHEMES

Option 1 - Local Zone Control With Wall Control	22
Option 2 - Building Management System (BMS) Interface	22
Remote On-Off (Input)	22
Cool/Vent (Input)	22
Fan Speed (Input)	22
Error Signal (Output)	22

WALL CONTROL INSTALLATION

Locating the Wall Control	23
Fixing the Wall Control Bracket to a Plasterboard Wall	23
Fixing the Wall Control Bracket to a Brick Wall	23
Fitting the Wall Control to the Mounting Bracket	23
Running the Wall Control Cable to the Wall Control	23

COMMISSIONING

Water Management System	24
Tank (Reservoir) Drain Valve Control	24
Inlet Solenoid Valve Control - Water	24
Pre-Wet Cycle	24
Pump Control	24
Salinity Control	24
Water Usage Sensing	24
Chlorinator Control	24
Testing the Cooler	25
Changing Control Parameters	25
Setting the Air Discharge Damper	26

INSTALLATION CHECKLIST

27

OPERATING INSTRUCTIONS

Wall Control	28
If '02' or '03' is Displayed	29
If '04' is Displayed	29

MAINTENANCE INSTRUCTIONS

Quarterly Inspection Procedures	30
Pump Maintenance & Replacement	30
Cleaning Pump Strainers & Impellers	30
Chlorinator Maintenance & Replacement	31
Water Management Probe Maintenance & Replacement	31
Drain Valve Maintenance & Replacement	32
Cleaning the Water Reservoir (Tank)	32
Solenoid Valve Maintenance & Replacement	32
Cleaning or Replacing Inlet Air Filters	33
Changing Cooler Cores	33
Cooler Cores - Orientation	34
Changing Cooler Chillcel Pads	35
Operating & Fault Code Diagnosis	36

MAINTENANCE SCHEDULE

39

SPARE PARTS

42

HOW TO REGISTER YOUR PRODUCT WARRANTY (Australia only)

43

WARRANTY TERMS & INFORMATION (Australia only)

44

Privacy Notice	46
----------------	----

IMPORTANT SAFETY INSTRUCTIONS

READ AND SAVE THESE INSTRUCTIONS FOR FUTURE REFERENCE.

FOR EUROPE

This appliance can be used by children aged from 8 years and above and persons with reduced physical, sensory or mental capabilities or lack of experience and knowledge if they have been given supervision or instruction concerning use of the appliance in a safe way and understand the hazards involved. Children shall not play with the appliance. Cleaning and user maintenance shall not be made by children without supervision.

FOR AUSTRALIA, NEW ZEALAND & OTHER NON-EUROPEAN COUNTRIES

This appliance is not intended for use by persons (including children) with reduced physical, sensory or mental capabilities, or lack of experience and knowledge, unless they have been given supervision or instruction concerning use of the appliance by a person responsible for their safety. Children should be supervised to ensure that they do not play with the appliance.

Means for all pole disconnection must be incorporated in the fixed wiring in accordance with the wiring rules, adjacent to or on the cooler cabinet. If mounting on the cooler cabinet, take care not to puncture the water reservoir.

The following specifications for the cooler water supply are required:

Water Connection ½" BSP (Aus/Eur), ½" NPT (USA)

Min Water Pressure 100kPa (15psi)

Max Water Pressure 800kPa (115psi)

Max Water Flow 20 L/min (5.3 gallons/min)

Max Water Temperature 40°C (104°F)

New hose sets supplied with the appliance are to be used and old hose-sets should not be re-used.

If the supply cord is damaged, it must be replaced by the manufacturer, its service agent or similarly qualified persons in order to avoid a hazard.

CAUTION: In order to avoid a hazard due to inadvertent resetting of the thermal cut-out, this appliance must not be supplied through an external switching device, such as a timer, or connected to a circuit that is regularly switched on and off by the utility.

FOR AUSTRALIAN BUSHFIRE PRONE AREAS

WARNING If this evaporative cooler is installed in a BAL-12.5 to 29 area the evaporative cooler dropper duct and flashings shall be adequately sealed at the roof to prevent gaps greater than 3mm. The dropper duct and flashings shall be non-combustible.

WARNING: This cooler is NOT APPROVED for installation in any bushfire zoned area/property (BAL-12.5 to BAL-FZ).

WARNING - TO REDUCE THE RISK OF FIRE, ELECTRIC SHOCK, OR INJURY TO PERSONS, OBSERVE THE FOLLOWING:

- a) Use this unit only in the manner intended by the manufacturer. If you have questions, contact the manufacturer.
- b) Before servicing or cleaning unit, switch power off at service panel and lock the service disconnecting means to prevent power from being switched on accidentally. When the service disconnecting means cannot be locked, securely fasten a prominent warning device, such as a tag, to the service panel.
- c) Installation work and electrical wiring must be done by qualified person(s) in accordance with all applicable codes and standards, including fire-rated construction.
- d) When cutting or drilling into wall or ceiling, do not damage electrical wiring and other hidden utilities.
- e) Do Not Use This Fan With Any Solid-State Speed Control Device.
- f) Ducted fans must always be vented to the outdoors.

EMPLOYER AND EMPLOYEE RESPONSIBILITIES

The installation and maintenance of evaporative coolers at height has the potential to create Occupational Health and Safety issues for those involved. Installers are advised to ensure they are familiar with the relevant State and Federal legislation, such as Acts, Regulations, approved Codes of Practice and Australian Standards, which offer practical guidance on these health and safety issues. Compliance with these regulations will require appropriate work practices, equipment, training and qualifications of workers.

Seeley International provides the following information as a guide to contractors and employees to assist in minimising risk whilst working at height.

IMPORTANT SAFETY INSTRUCTIONS

INSTALLER AND MAINTENANCE CONTRACTORS - RISK ASSESSMENT

Installer and Maintenance Contractors

A risk assessment of all hazardous tasks is required under legislation. A risk assessment is an essential element that should be conducted before the commencement of work, to identify and eliminate the risk of falls or to minimise these risks by implementing control measures. There is no need for this to be a complicated process, it just is a matter of looking at the job to be done and considering what action(s) are necessary so the person doing the job does not injure themselves.

This should be considered in terms of:

- What are the chances of an incident happening?
- What could the possible consequence be?
- What can you do to reduce, or better still, completely get rid of the risk?

SOME POINTS TO CONSIDER

- What is the best and safest access to the roof and working areas?
- If a worker is alone, who knows they are there and if they get into difficulty, how can they summon help?
- (Call someone on the ground? Mobile phone? etc.)
- What condition is the roof in? Should the trusses, underside or surface be checked?
- Does the worker have appropriate foot wear? (Flat sole jogger type is advisable)
- Are all power cables / extension leads safe and appropriately rated?
- Are all ladders, tools and equipment suitable in good condition?
- Where ladders are to be used, is there a firm, stable base for them to stand on? Can they be tied or secured in some way at the top? Is the top of the ladder clear of electricity supply cables?
- Is there a roof anchor to attach a harness and lanyard to? If so, instruction should be issued for the use of an approved harness or only suitably trained people used.
- Are all tools and materials being used, prevented from slipping and falling onto a person at ground level? Is the area below the work area suitably protected to prevent persons walking in this area?
- Does the work schedule take into account weather conditions, allowing for

work to be suspended in high winds, thunder storms/lightning or other types of weather giving wet, slippery surfaces?

- Is there an on-going safety check system of harnesses, ropes, ladders and access/lifting equipment and where they exist on roofs, anchor points before the commencement of work?
- Is there a system which prevents employees from working on roofs if they are unwell or under the influence of drugs or alcohol?
- Are there any special conditions to consider i.e. excessive roof pitch, limited ground area, fragile roof, electrical power lines?

OTHER IMPORTANT REQUIREMENTS

- Never force parts to fit because all parts are designed to fit together easily without undue force.
- Never drill holes in the tank of the cooler.
- Check the proposed cooler location, to ensure that it is structurally capable of supporting the weight of the cooler, or provide an adequate alternate load bearing structure.
- Ensure the installation complies with all local and national regulations with regards to electrical, plumbing and bushfire construction requirements.

MAINTENANCE NOTE

IMPORTANT

As with any product that has moving parts or is subject to wear and tear, it is **VERY IMPORTANT** that you maintain your cooler and have it regularly serviced. It is a condition of warranty cover for your cooler that you comply with all of the maintenance and service requirements set out in this Manual. Compliance with these requirements will prolong the life of your cooler. Further, it is also a condition of warranty cover that each item in the Maintenance Schedule in the Manual is filled out (by signing and dating it in the places indicated) when the item is completed.

Any failure to carry out the required maintenance and servicing, and any failure to fill out the maintenance schedule, will void your warranty.

COOLER VIEWS

ISOMETRIC

CW-H10 views shown

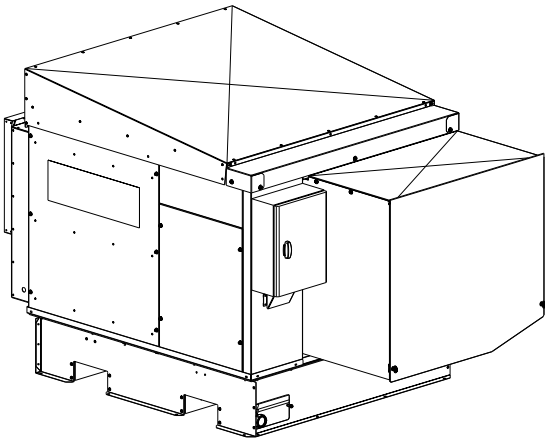

ILL3156-A

TOP

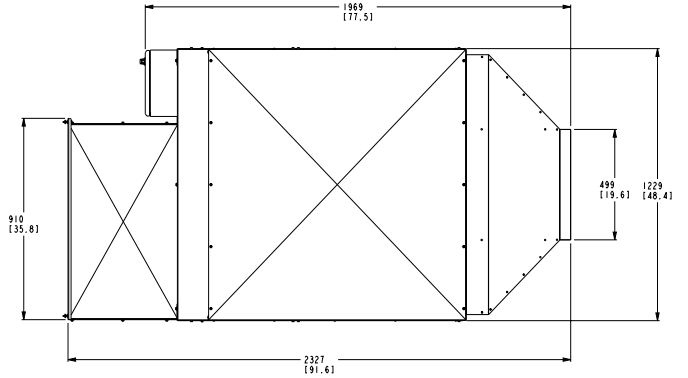

ILL3157-A

REAR

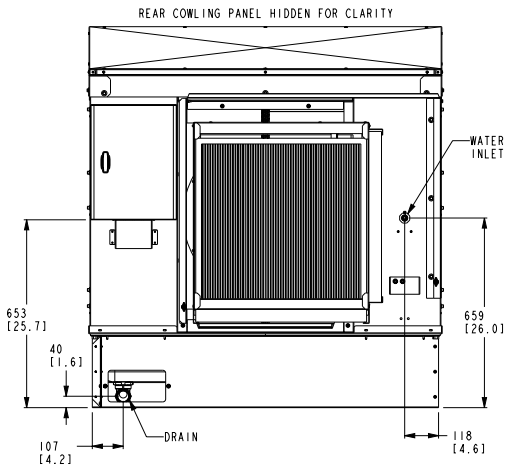

ILL3158-A

SIDE

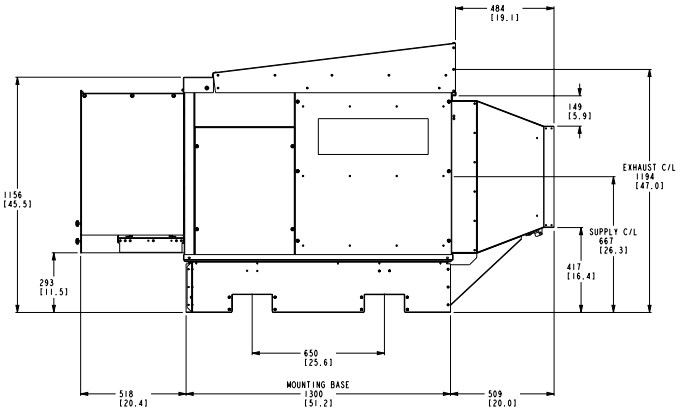

ILL3159-A

FRONT

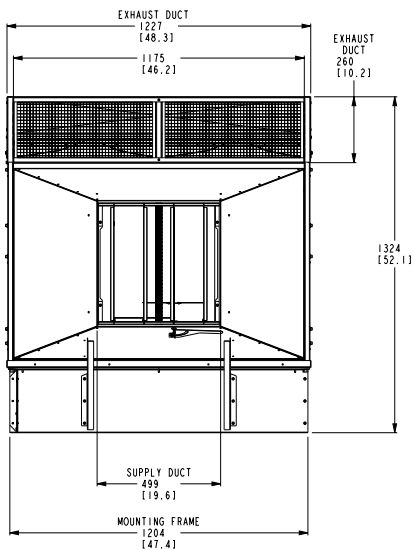

ILL3160-A

BOTTOM

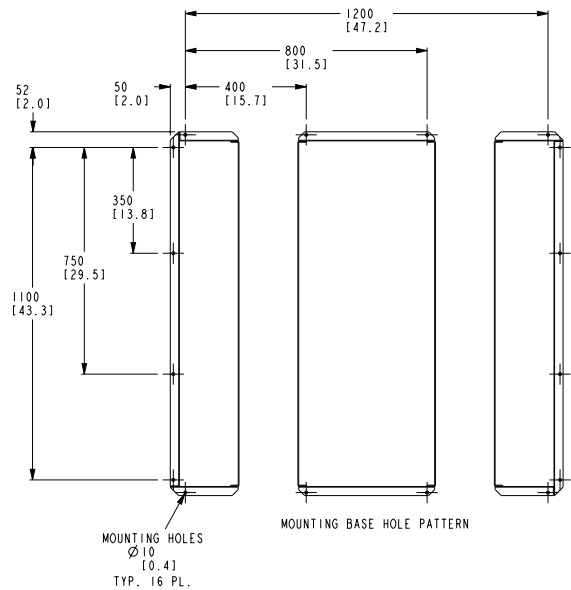

ILL3161-A

Dimensions are in mm (inches in brackets).

COOLER VIEWS

ISOMETRIC

CW-H15 views shown

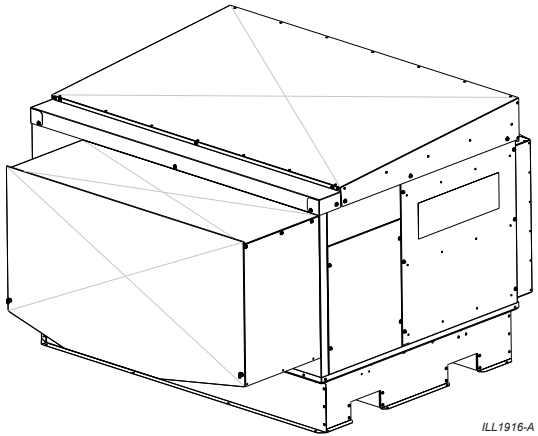

ILL1916-A

TOP

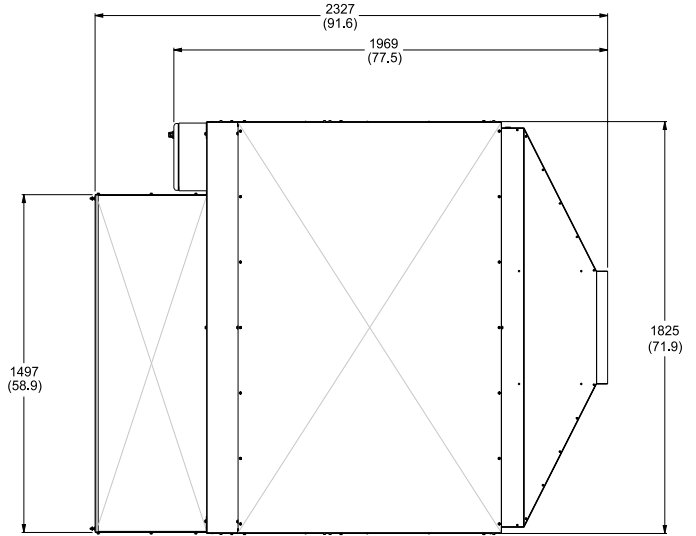

ILL1918-A

REAR

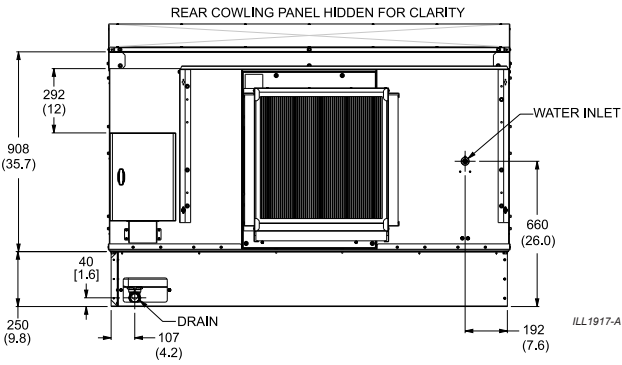

ILL1917-A

SIDE

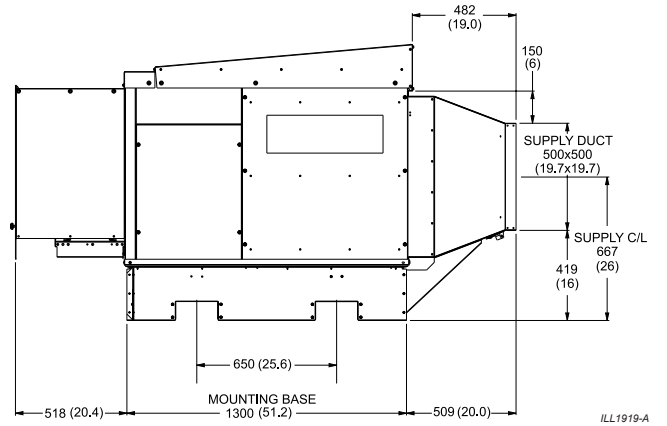

ILL1919-A

FRONT

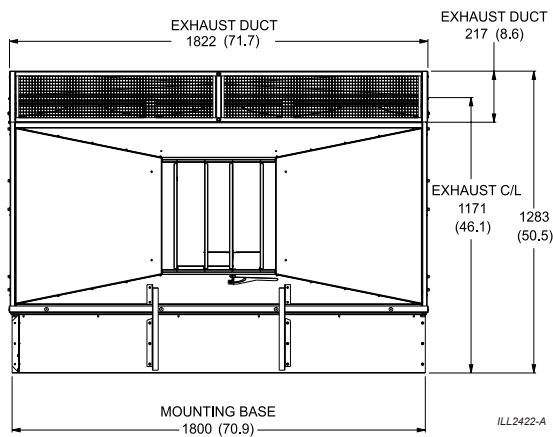

ILL2422-A

BOTTOM

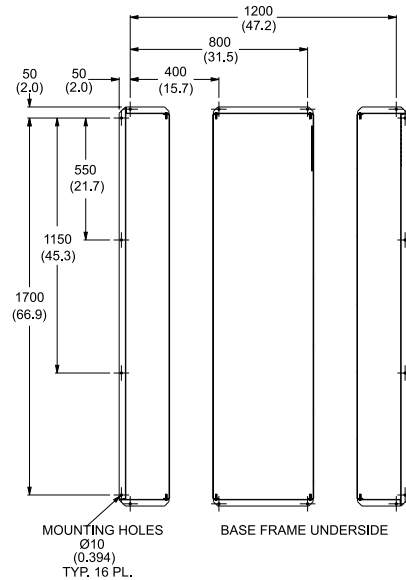

ILL1920-A

Dimensions are in mm (inches in brackets).

Dimensions are in mm (inches in brackets).

COOLER EXPLODED VIEW

ILL2423-A

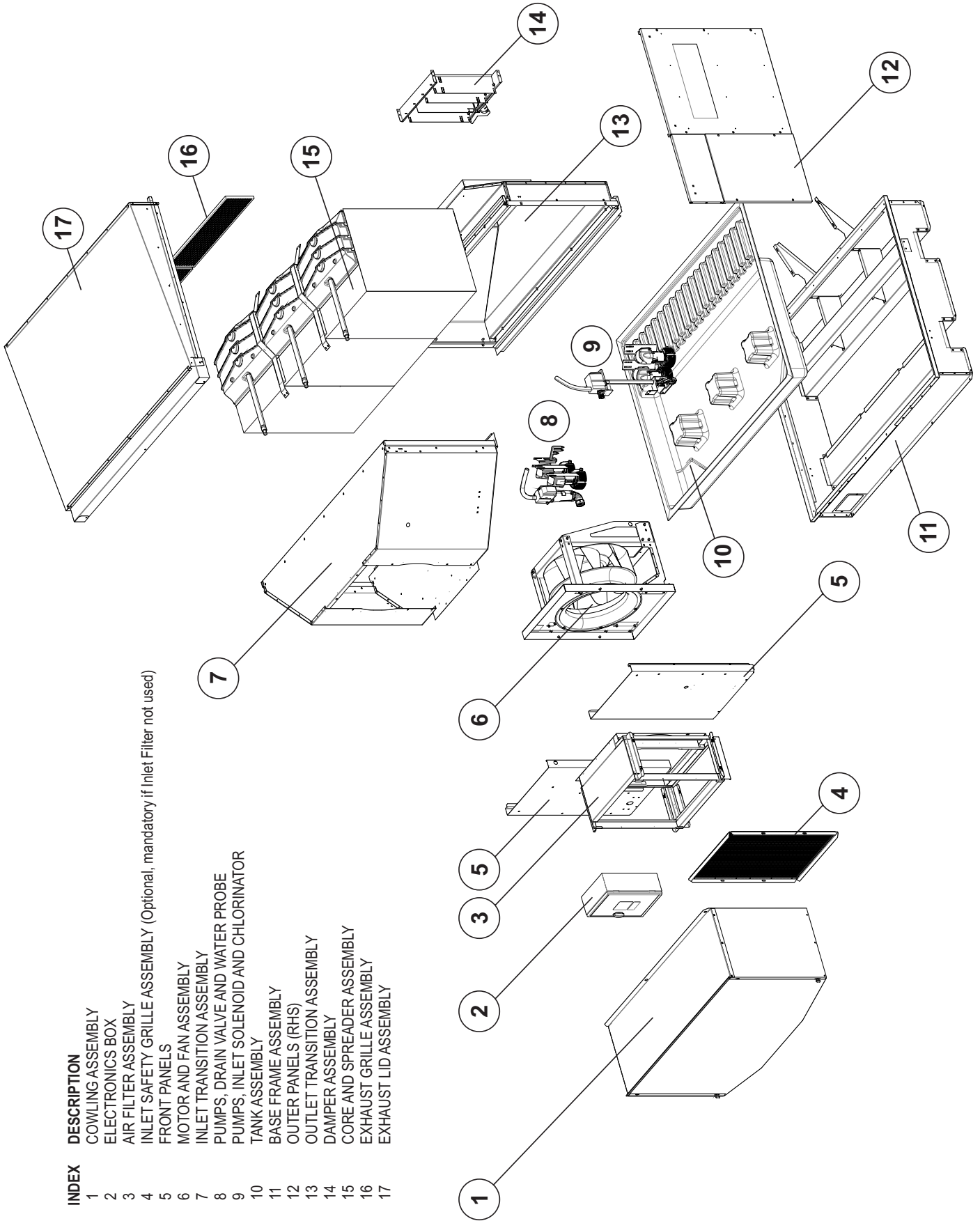

INDEX

- | | |
|-----------------------------------------------------------------------------|--------------|
| DESCRIPTION | INDEX |
| COWLING ASSEMBLY | 1 |
| ELECTRONICS BOX | 2 |
| AIR FILTER ASSEMBLY | 3 |
| INLET SAFETY GRILLE ASSEMBLY (Optional, mandatory if Inlet Filter not used) | 4 |
| FRONT PANELS | 5 |
| MOTOR AND FAN ASSEMBLY | 6 |
| INLET TRANSITION ASSEMBLY | 7 |
| PUMPS, DRAIN VALVE AND WATER PROBE | 8 |
| PUMPS, INLET SOLENOID AND CHLORINATOR | 9 |
| TANK ASSEMBLY | 10 |
| BASE FRAME ASSEMBLY | 11 |
| OUTER PANELS (RHS) | 12 |
| OUTLET TRANSITION ASSEMBLY | 13 |
| DAMPER ASSEMBLY | 14 |
| CORE AND SPREADER ASSEMBLY | 15 |
| EXHAUST GRILLE ASSEMBLY | 16 |
| EXHAUST LID ASSEMBLY | 17 |

COOLER SPECIFICATIONS

TECHNICAL SPECIFICATIONS - METRIC CW-H MODELS

Specification		CW-H10	CW-H15	CW-H15S	CW-H15S Plus
Capacity	Airflow	800 L/s @ 180 Pa	1100 L/s @ 150 Pa	1100 L/s @ 130 Pa	1600 L/s @ 80 Pa
	Maximum External Static Pressure	230 Pa	215 Pa	195 Pa	155 Pa
	Nominal Cooling Capacity*	18 kW	24 kW	28 kW	40 kW
	COP	12	14	16	18
Electrical Supply	Voltage	380-415V/3N~	380-415V/3N~	380-415V/3N~	380-415V/3N~
	Frequency	50 Hz	50 Hz	50 Hz	50 Hz
	Rated Current	3A	3A	3A	3A
	Input Power	1.5 kW	1.8 kW	1.8 kW	2.2 kW
Fan/Motor	Type	560mm dia Backward Curved	560mm dia Backward Curved	560mm dia Backward Curved	560mm dia Backward Curved
	Control	Variable Speed ECM PWM Control	Variable Speed ECM PWM Control	Variable Speed ECM PWM Control	Variable Speed ECM PWM Control
	Maximum Speed	1285 rpm	1350 rpm	1350 rpm	1460 rpm
Heat Exchanger	Indirect Evaporative	2 Cores	3 Cores	3 Cores	3 Cores
	Direct Evaporative	None	None	3 Chillcel Pads	3 Chillcel Pads
Water	Water Supply	Min. 100kPa, Max 800kPa, 20L/min	Min. 100kPa, Max 800kPa, 20L/min	Min. 100kPa, Max 800kPa, 20L/min	Min. 100kPa, Max 800kPa, 20L/min
	Inlet	1/2" male BSP 12V Solenoid	1/2" male BSP 12V Solenoid	1/2" male BSP 12V Solenoid	1/2" male BSP 12V Solenoid
	Water Consumption	44 L/hr	56 L/hr	60 L/hr	72 L/hr
	Tank	45 L	65 L	65 L	65 L
	Pumps	2 pumps, 13 L/min @ 1.5m head. 230V 50Hz Input power 30W/ea	3 pumps, 13 L/min @ 1.5m head. 230V 50Hz Input power 30W/ea	4 pumps, 13 L/min @ 1.5m head. 230V 50Hz Input power 30W/ea	4 pumps, 13 L/min @ 1.5m head. 230V 50Hz Input power 30W/ea
	Drain	12V motor, 40mm (1 1/2") Male BSP or 20mm Push-On	12V motor, 40mm (1 1/2") Male BSP or 40mm Flexible Coupling	12V motor, 40mm (1 1/2") Male BSP or 40mm Flexible Coupling	12V motor, 40mm (1 1/2") Male BSP or 40mm Flexible Coupling
	Chlorinators	1 chlorinator	1 chlorinator	1 chlorinator	1 chlorinator
Air Filters	Type G4 washable	305 * 610 * 50mm Qty 2 610 * 610 * 50 Qty 1	305 * 610 * 50mm Qty 3 610 * 610 * 50 Qty 1	305 * 610 * 50mm Qty 3 610 * 610 * 50 Qty 1	305 * 610 * 50mm Qty 3 610 * 610 * 50 Qty 1
Dimensions	Shipping (Including Pallet)	2050mm long 1375mm wide 1280mm high	2050mm long 2000mm wide 1280mm high	2050mm long 2000mm wide 1280mm high	2050mm long 2000mm wide 1280mm high
	Operating (Including Filters and Cowling)	2330mm long 1230mm wide 1610mm high	2330mm long 1825mm wide 1285mm high	2330mm long 1825mm wide 1285mm high	2330mm long 1825mm wide 1285mm high
Weight	Shipping (Including Pallet)	250 kg	320 kg	335 kg	335 kg
	Operating (Including Filters, Cowling, Water)	255 kg	325 kg	340 kg	340 kg
Duct Connections	Supply	500 x 500 mm	500 x 500 mm	500 x 500 mm	500 x 500 mm
	Exhaust	1230 x 260 mm	1825 x 220 mm	1825 x 220 mm	1825 x 220 mm

*Tested in accordance with ASHRAE 143 with conditions of 38.0 C Dry Bulb / 21.0 C Wet Bulb. Stand alone cooling capacity may be lower, depending on application.

FREQUENCY (Hz)	Air Inlet Sound Power level (db re 1 pW) Octave Band Centre Frequency							Total Sound Power (db re 1pW)
	125	250	500	1k	2k	4k	8k	
CW-H10	70	60	58	57	54	50	42	63
CW-H15	84	68	65	62	55	51	44	70
CW-H15S	68	69	64	63	60	53	44	73
CW-H15S Plus	71	70	66	64	61	55	48	75

COOLER SPECIFICATIONS

TECHNICAL SPECIFICATIONS - IMPERIAL CW-H MODELS

Specification		CW-H15	CW-H15S	CW-H15S Plus
Capacity	Airflow	2330 CFM @ 0.60 in WG	2330 CFM @ 0.52 in WG	3390 CFM @ 0.32 in WG
	Maximum External Static Pressure	0.86 IWG	0.78 IWG	0.62 IWG
	Nominal Cooling Capacity	82,000 BTU/hr	93,800 BTU/hr	135,500 BTU/hr
	EER	46	53	61
Electrical Supply	Voltage / Frequency / Current	Option 1 - 440-480V/3~/60Hz 3A per Phase / 8.5 MCA / 15 MOPD		
		Option 2 - 200-240V/3~/60Hz 6A per Phase / 14.5 MCA / 20 MOPD		
		Option 3 - 200-240V/1~/60Hz 8A per Phase / 11.5 MCA / 15 MOPD		
Input Power	1.8 kW	1.8 kW	2.2 kW	
Fan/Motor	Type	22" dia Backward Curved	22" dia Backward Curved	22" dia Backward Curved
	Control	Variable Speed ECM PWM Control	Variable Speed ECM PWM Control	Variable Speed ECM PWM Control
	Maximum Speed	1350 rpm	1350 rpm	1460 rpm
Heat Exchanger	Indirect Evaporative	3 Cores	3 Cores	3 Cores
	Direct Evaporative	None	3 Chillcel Pads	3 Chillcel Pads
Water	Water Supply	Min. 15 psi, Max 115 psi, 5.3 gal/min	Min. 15 psi, Max 115 psi, 5.3 gal/min	Min. 15 psi, Max 115 psi, 5.3 gal/min
	Water Consumption	15 gal/hr	16 gal/hr	19 gal/hr
	Inlet	1/2" male NPT 12V Solenoid	1/2" male NPT 12V Solenoid	1/2" male NPT 12V Solenoid
	Tank	17 gal	17 gal	17 gal
	Pumps	3 pumps, 3.4gal/min @ 4.9' head. 220V 60Hz Input power 32W/ea	4 pumps, 3.4gal/min @ 4.9' head. 220V 60Hz Input power 32W/ea	4 pumps, 3.4gal/min @ 4.9' head. 220V 60Hz Input power 32W/ea
	Drain	12V motor, 1½" (40mm) Male BSP or 1½" (40mm) Flexible Coupling	12V motor, 1½" (40mm) Male BSP or 1½" (40mm) Flexible Coupling	12V motor, 1½" (40mm) Male BSP or 1½" (40mm) Flexible Coupling
	Chlorinators	1 chlorinator	1 chlorinator	1 chlorinator
Air Filters	MERV 10 washable	12 * 24 * 2" Qty 3 24 * 24 * 2" Qty 1	12 * 24 * 2" Qty 3 24 * 24 * 2" Qty 1	12 * 24 * 2" Qty 3 24 * 24 * 2" Qty 1
		81" * 79" * 51"H	81" * 79" * 51"H	81" * 79" * 51"H
Shipping	including pallet	705 lb	740 lb	740 lb
		92" * 72" * 51"H	92" * 72" * 51"H	92" * 72" * 51"H
Operating	including filters, cowling	715 lb	750 lb	750 lb
	including filters, cowling, water	715 lb	750 lb	750 lb
Duct Connections	Supply	20 * 20"	20 * 20"	20 * 20"
	Exhaust	70 * 8.5"	70 * 8.5"	70 * 8.5"

*Tested in accordance with ASHRAE 143 with conditions of 100 F Dry Bulb / 70 F Wet Bulb.
Stand alone cooling capacity may be lower, depending on application.

FREQUENCY (Hz)	Air Inlet Sound Power level (db re 1 pW) Octave Band Centre Frequency								Total Sound Power (db re 1pW)
	125	250	500	1k	2k	4k	8k		
CW-H10	70	60	58	57	54	50	42	63	
CW-H15	84	68	65	62	55	51	44	70	
CW-H15S	68	69	64	63	60	53	44	73	
CW-H15S Plus	71	70	66	64	61	55	48	75	

COOLER CONTENTS

COOLER INSTALLATION COMPONENTS

Item	Part No.	Description	QTY
1	834245	Control Cable 20m (65')	1
2A	114279	Wall Control CW-H	1
2B	584331	Plate Mount Wall Control	1
2C	804644	Screw Pan Ph 6AB*1" ZNP	2
2D	805306	Plug Rawl Yellow 5mm Dia	2
3	859379	Instruction - Installation, Operation, Maintenance	1
4	879345	Warranty Card (USA Only)	1
5A	861883	Adaptor Drain Elbow	1
5B	866217	Adaptor, Drain Flexible 40mm (1½")	1
6	-	Handle, Control Box	1
7A	637994	Exhaust Centre Post CW-H15, H15S, H15S Plus	1
7B	637393	Exhaust Centre Post CW-H10	1
8A	805597	Screw 8AB x ½" Pan Phill SS	10
8B	804446	Screw SEMS HX 14*3/4" ZNP	11
8C	804422	Plastic Grommet Size 14	5
8D	864341	Screw Set SHCS M6*35mm SS	4
8E	864385	Washer Flat M6*12.5OD*1.2 SS	4
8F	864372	Washer Flat NYLON M8*16OD	4
9	931685	Exhaust Side Rails (1176mm Long) (UNDER LID)	2
10A	834789	Exhaust Grille (869x205) (UNDER LID) CW-H15, H15S, H15S Plus	1
10B	834790	Exhaust Grille (571x247) (UNDER LID) CW-H10	1
11	637999	Exhaust Cap (UNDER LID) CW-H15S Plus Only	2

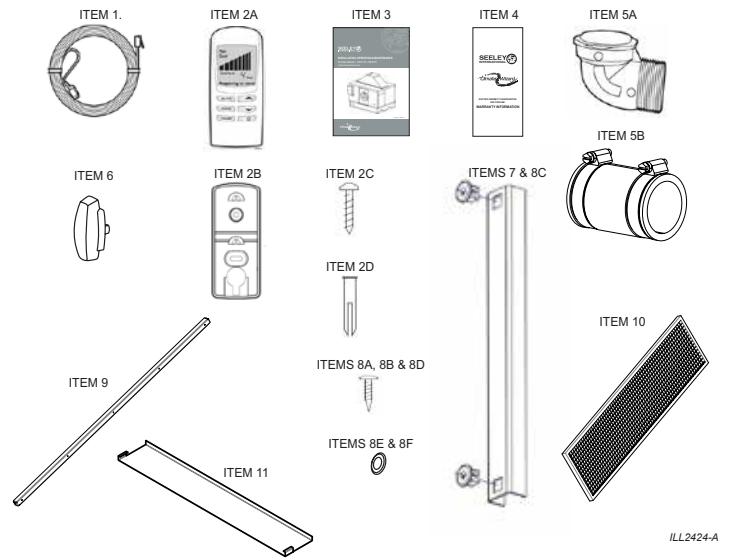

ILL2424-A

OPTIONAL COMPONENTS

Item	Seeley Part	Description
1	120202	Inlet Air Safety Grille
2A	120409	Inlet Air Filter Frame inc. Filters (CW-H10)
2B	120379	Inlet Air Filter Frame inc. Filters (CW-H15, H15S, H15S Plus)
3A	120416	Inlet Air Filter Cowling (CW-H10)
3B	120386	Inlet Air Filter Cowling (CW-H15, H15S, H15S Plus)
4	094724	Control Cable 40M
5A	134192	Roofstand 0-10° (CW-H10)
5B	134215	Roofstand 0-10° (CW-H15, H15S, H15S Plus)
6A	094397	CW-H15S Conversion 380-480V/3~
6B	093970	CW-H15S Conversion 220-240V/3~
6C	094007	CW-H15S Conversion 220-240V/1~
7A	094366	High Altitude Smartcard 380-480V/3~ (CW-H15)
7B	TBC	High Altitude Smartcard 200-240V/3~ (CW-H15)
7C	TBC	High Altitude Smartcard 200-240V/1~ (CW-H15)

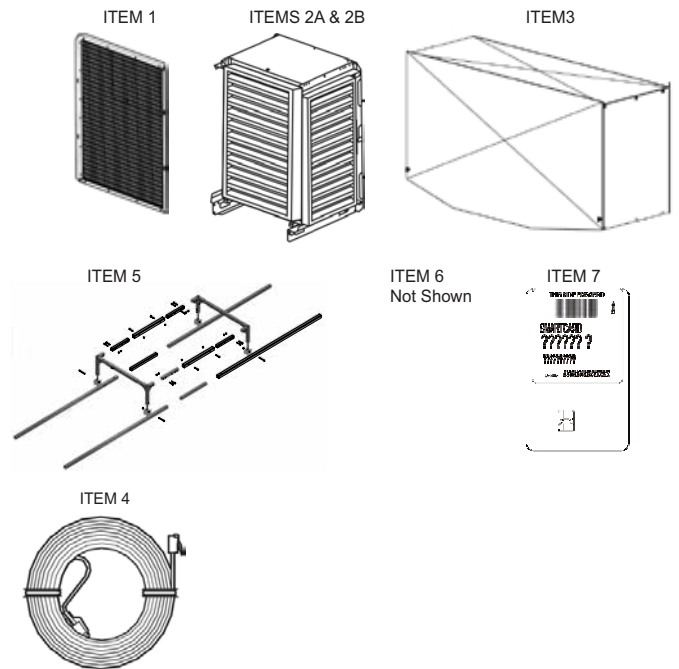

ILL2425-A

INSTALLATION

COOLER LOCATION

Check the proposed cooler location, to ensure that it is structurally capable of supporting the weight of the cooler, or provide an adequate alternate load bearing structure.

Model	Shipping Weight	Operating Weight
CW-H10	250kg (550 lb)	255kg (560 lb)
CW-H15	320kg (705 lb)	325kg (715 lb)
CW-H15S, H15S Plus	335kg (740 lb)	340kg (750 lb)

Always locate the cooler where it will receive a plentiful supply of fresh air, NOT in a recess where it may be starved for air or where the air is polluted.

Air exiting the exhaust hood is warm and heavily laden with moisture. Ensure the cooler's exhaust outlet location will not cause corrosion or damage to other nearby items. Do not allow exhaust air to re-circulate into the air intake of the cooler.

Ensure the location is a minimum of:

- 3.0m (10') from a solid fuel heater flue,
- 1.5m (5') from a gas flue,
- 5.0m (16') from a sewer vent
- Rear = Min 1.0m (3.5') from a wall, 1.0m (3.5') at sides to allow easy access for maintenance and core replacement.

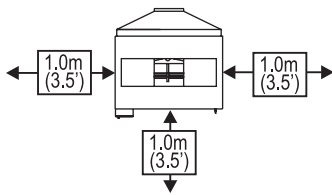

ILL1925-A

Allow adequate access to and around the cooler for maintenance. Provision must be made for access to electricity, water supplies and drains.

Note! Do you need to discuss the installation of items like safety anchor points with the customer?

MOUNTING/SUPPORT

Industry standard support frames can be used with this cooler.

Recommended steel specification:

50 x 50 x 3mm (2" x 2" x 1/8") RHS Galvanized or Painted

Specific CW-H Roofstands are available for order via Seeley International to suit cooler size and accommodating 5 or 10 degree roof pitches.

CW-H10: 0-10° - P/No. 134192

CW-H15: 0-10° - P/No. 134215

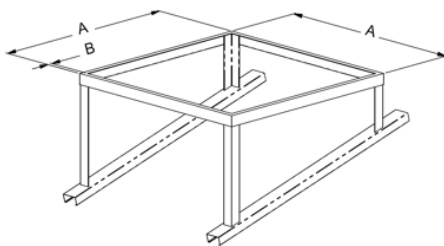

ILL2426-A

CW-H10:
A = 1300mm (51.2") x 1206mm (47.5")

CW-H15, H15S, H15S Plus:
A = 1300mm (51.2") x 1800mm (70.9")

CW-H10, CW-H15, H15S, H15S Plus:
B = 50mm min (2" min.)

Angle to match roof pitch

UNPACKING THE COOLER

The cooler will be delivered wrapped in a plastic stretch wrap film which will need to be removed before installation. A small bag of installation components along with the exhaust transition side rails and grilles can be found under the lid of the main cabinet of the cooler. The exhaust transition will need to be raised into place before operation.

The wall control and communications cable, along with ancillary mount plates, fasteners and drain adaptors will need to be placed aside for later connection.

WARNING: Once unwrapped, the exhaust transition assembly should be fitted together as soon as practicable to avoid loose components becoming lost/damaged and/or a hazard.

MOVING THE COOLER

The cooler has in-built fork-truck tyne openings in the base for ease of movement. The openings can also be used with lifting straps or slings (refer diagram & see below).

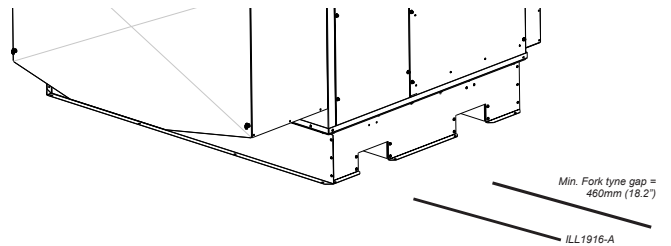

LIFTING THE COOLER

The cooler may be lifted either by fork-truck or crane with slings. The method for lifting by crane is by lifting straps through the cooler base fork-truck tyne openings. Do not attempt to lift using any cabinet features or by retro-fitting lifting lugs. The cabinet may be damaged and/or lift safety compromised.

It is recommended to use a spreader bar on the straps or slings and/or to protect the upper edges of the cooler with a corner protector beneath the lifting straps to avoid any damage to the cabinet during the lift.

VIBRATION ISOLATION

Waffle pads are recommended to be used under each corner of the cooler. Pad size approx. 200mm (8") x 200mm (8"). Use industry standard methods of fixing to the building structure.

DRIP-TRAY

When Climate Wizard coolers are installed indoors, or anywhere that water leakage could cause damage, install a corrosion resistant drip tray under the whole machine. Recommended sizes:

CW-H10:
1500w x 1300d x 50h mm (59"w x 51"d x 2"h)

CW-H15, H15S, H15S PLUS:
1500w x 1900d x 50h mm (59"w x 75"d x 2"h)

Apply silicone sealant between drip-tray and cooler base at every fixing.

SUPPLY AIR DUCT CONNECTIONS

Vibration absorbing flexible connections are recommended for all duct connections to the cooler, for any ducts that are attached to the building structure. All ducts attached to the flexible connection must be independently supported.

INSTALLATION cont.

EXHAUST TRANSITION ASSEMBLY

The exhaust transition is supplied in knock-down form and its components are to be found beneath the lid of the cooler and inside the component kit.

1. Lift the large top panel and locate;
 - 2 x EXHAUST SIDE RAILS (1176mm Long)
 - 2 x EXHAUST GRILLE
 - 2 x EXHAUST CAPS (CW-H15S Plus Only)
2. Fit the EXHAUST SIDE RAILS to the inside vertical faces of the large top panel with the supplied 10 x SCREW PAN PHILLIPS 8AB*1/2" SS. Ensure the foam seal faces down.

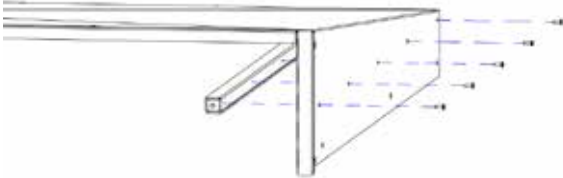

ILL2427-A

3. Fit the supplied 3 x PLASTIC GROMMET SIZE 14 to the rear lid panel upstand square holes.



ILL2428-A

4. Fit the supplied 2 x PLASTIC GROMMET SIZE 14 to the EXHAUST CENTRE POST.

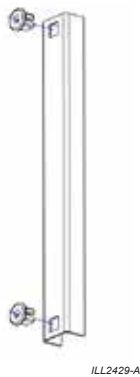

ILL2429-A

5. Position the large top panel over the top of the cooler, with the rear u-channel over the top of the upstand, the side rails sitting on the tops of the cooler side walls and the end posts sitting on the outside of the front tray.

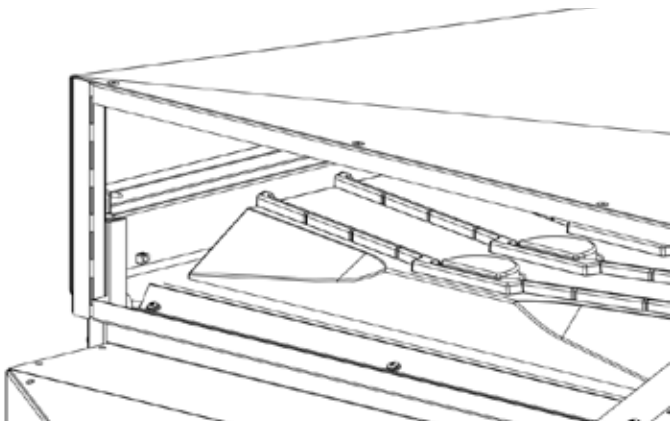

ILL2428-A

6. Slip the 2 x EXHAUST GRILLE and 1 x EXHAUST CENTRE POST into position, retained inside the top panel front u-channel.

CW-H15S Plus ONLY: Before fitting to the cooler, slide an EXHAUST CAP over the **back** of each EXHAUST GRILLE. The EXHAUST CAP covers the top portion of the EXHAUST GRILLE, and is designed to optimise the CW-H15S Supercool performance.

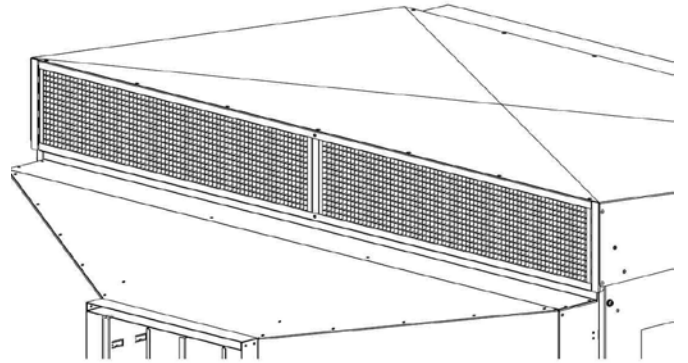

ILL2431-A

7. Screw the exhaust transition assembly to the cooler body with the supplied 11 x SCREW SEMS HEX 14 x 3/4" ZP. 3 x Rear Upstand, 3 x Left Side, 3 x Right Side, 2 x Centre Post.
8. Fit the supplied 4 x M6 x 35MM SET SCREW, STAINLESS STEEL FLAT WASHER, NYLON FLAT WASHER to the tops of both core access doors. Apply a liberal coat of anti-seize paste to the screw thread prior to fitment.

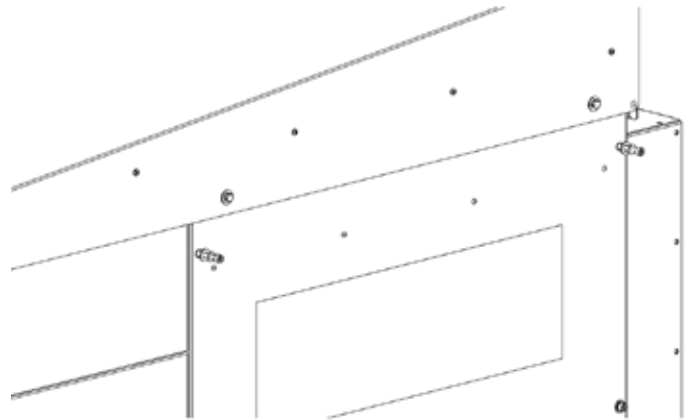

ILL2432-A

EXHAUST DUCT CONNECTION REQUIREMENTS

If required, the exhaust discharge opening may be ducted away from the cooler. When designing the exhaust duct please note the following;

- The exhaust air is warm and heavily laden with moisture. Ensure the exhaust opening is located and oriented in such a way as to avoid exhaust air re-entering the cooler inlet.
- Access to the heat exchanger cores requires the removal of the cooler lid/exhaust transition. Ensure any additional ducting is readily removable and/or lightweight.
- Where an installation requires extended exhaust ducts, the increase in static load should not exceed 20 Pa (0.08 in wg).

INSTALLATION cont.

INLET AIR FILTER ASSEMBLY OR SAFETY GRILLE

Climate Wizard coolers **SHOULD NEVER BE INSTALLED WITHOUT DUST FILTERS.**

Use either the Inlet Air Filter Assembly supplied from the factory or use the cooler with pre-filtered air to EN779 G4 or ASHRAE 52.2 MERV8 standards.

Should the Inlet Air Filter Assembly not be required an Inlet Air Safety Grille is available and **MUST** be fitted for safety reasons. Other Safety Grilles cannot be substituted.

The Inlet Air Filter Assembly or Safety Grille is supplied in separate cartons when shipped with the Climate Wizard.

OPTION 1 – INLET AIR SAFETY GRILLE (FOR USE WITH PRE-FILTERED AIR ONLY)

CW-H10, CW-H15, H15S, H15S Plus: = P/N 120102



ILL2433-A

Fit the Inlet Air Safety Grille using the 4 x M6 X 16MM SET SCREWS AND WASHERS pre-fitted to the inside surfaces of the air inlet recess.

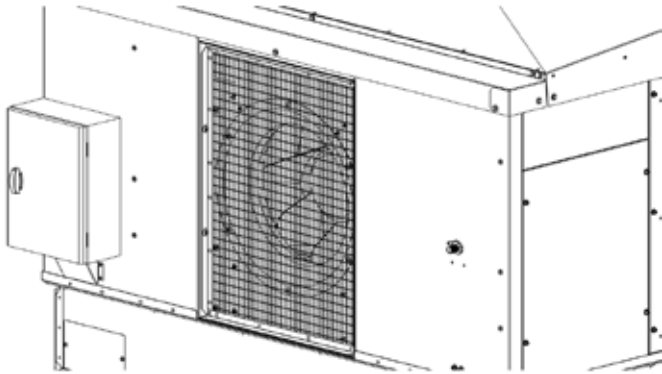

ILL2434-A

OPTION 2 - INLET AIR FILTER ASSEMBLY

CW-H10: = P/N 120409

CW-H15, H15S, H15S Plus: = P/N 120379

1. Remove the air filters from their shipping position in the frame.
2. Fit the Inlet Air Filter Assembly using the 4 x M6 x 16mm Set Screws and Washers pre-fitted to the front face of the air inlet recess. Ensure the frame is centred around the fan inlet cone.

CW-H10

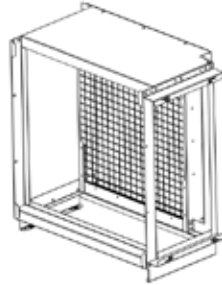

ILL2436-A

CW-H15, H15S, H15S Plus

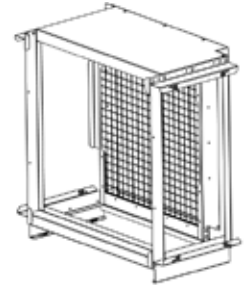

ILL2437-A

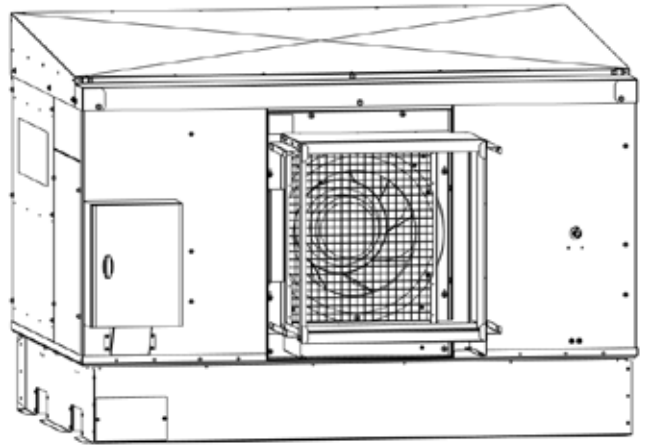

ILL2435-A

3. Re-fit the air filters, ensuring the sticker showing direction of air flow is the correct way round.

INSTALLATION cont.

INLET AIR FILTER COWLING ASSEMBLY

Climate Wizard coolers installed outside should be fitted with an inlet air cowling assembly to protect the air filters from exposure to water. It features a detachable front panel for easy access to the filters.

The Inlet Air Cowling Assembly is supplied in a separate carton when shipped with the Climate Wizard. It contains a small bag of fasteners required for fitment to the cooler.

CW-H10: = P/N 120416

CW-H15, H15S, H15S Plus: = P/N 120386

1. Fit the 2 x Cowling Side Panels. Ensure the black plastic fitting is at the bottom of the panel.
 - a. CW-H15, H15S, H15S Plus: – Screw the cowling side panels to the cooler using the supplied 6 x SCREW SEMS HEX 14 x 3/4" ZP into the pre-fitted plastic grommets fitted to the cooler body.

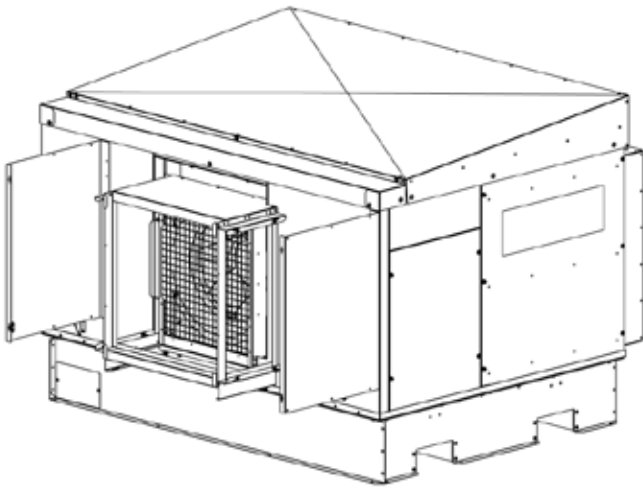

ILL2438-A

- b. CW-H10 – Fit the right hand side panel as above. Fit the left hand side panel using the same pre-fitted M6 x 16mm Set Screws and Washers used to fit the filter frame to the cooler.
2. Fit the supplied 6 x PLASTIC GROMMET SIZE 14 to the sides of the Cowling Top Panel
 3. Remove the pre-fitted centre and right hand screws from the cooler lid back panel. Slip the long large upstand of the Cowling Top Panel under the lip of the cooler lid back panel and re-fit the screws.

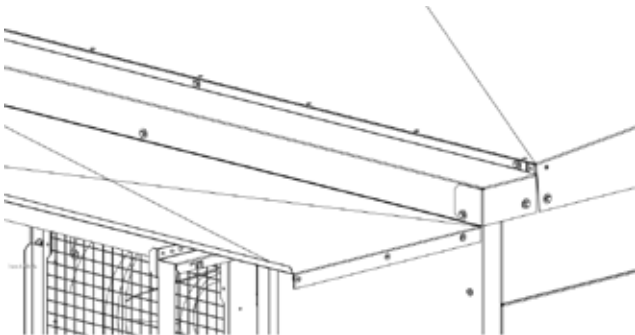

ILL2439-A

4. Screw the cowling side panel and the top panel to the cooler body with supplied 6 x SCREW SEMS HEX 14 x 3/4" ZP.
5. Fit the supplied 2 x quarter-turn, self-ejecting fasteners to the Cowling Front Panel. Ensure the supplied split washer is fitted as shown.



ILL2440-A

6. Rest the return fold of the cowling front panel on the lip of the top panel. Secure the bottom corners using the quarter-turn self-ejecting fasteners.

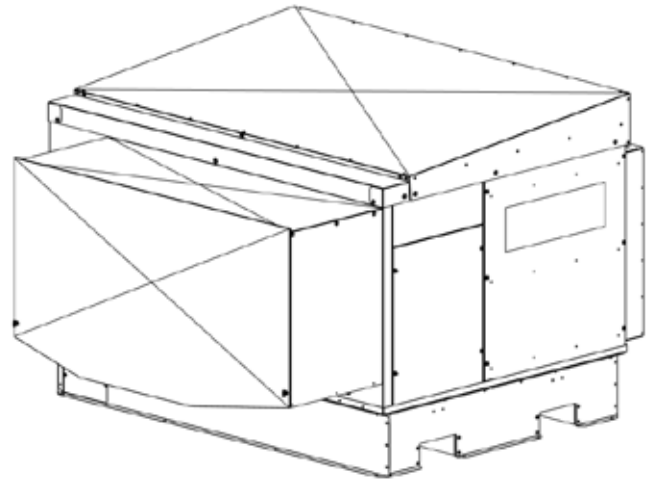

ILL2441-A

INSTALLATION cont.

WATER SUPPLY INSTALLATION

Climate Wizard requires a permanent water supply to be connected.

Installation of the water supply to the cooler must conform to local plumbing rules, regulations and standards:

The following specifications for water supply are required:

- **Water Connections:**
1/2" BSP (Aus/Eur), 1/2" NPT (USA)
male connection supplied suitable for a compression fitting.
- **Water Supply:**
100kPa (15psi) - 800 kPa (115psi)
MAXIMUM @ 20L/min (5.3 gal/min)
- **Water Supply Temperature:**
40°C (105°F) MAXIMUM
- **Water Supply Salinity:**
100 to 1150µS/cm

Important! If the water pressure exceeds this maximum specification then a pressure reducing valve is required and must be supplied and fitted by the installer.

The installer must provide a manual 1/4 turn ball type shut off valve (do not use a stop cock) in the water supply line adjacent to the cooler, subject to local plumbing regulations. This allows the water supply to be isolated whenever work needs to be done on the cooler.

In areas subject to freezing, the water line needs a drain down facility.

WATER SUPPLY FILTRATION

Seeley International requires an inlet filter to be installed on the water supply line, external to the Climate Wizard cooler to prevent any debris from entering and damaging cooler components.

Important! Flush the water pipe to remove any contaminants (swarf, filings or dirt) before final fitting. Contaminants can lodge in the solenoid, preventing it from functioning correctly.

Climate Wizard's water management system is designed to use water that is suitable to be classified as 'potable' and fit for human consumption. If alternative water (including rain water) is to be used that contains high levels of salinity, hardness, acidity or chemical contaminants, then additional filtration or treatment systems should be employed to render the water 'potable'.

WATER HAMMER

Not all installation pipeworks are the same, and some may require additional prevention against water hammer.

If water hammer is a problem, it is the responsibility of the Installer to fit an appropriate water hammer arresting device external to the cooler.

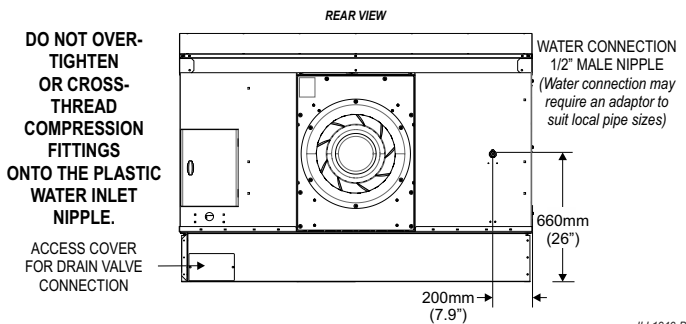

WATER DRAIN INSTALLATION

Climate Wizard coolers require a permanent water drain to be connected. A built-in Drain Valve, controlled by the water management system, releases water from the cooler when required.

The cooler installation kit contains components to configure the Drain Valve discharge to one of the following options;

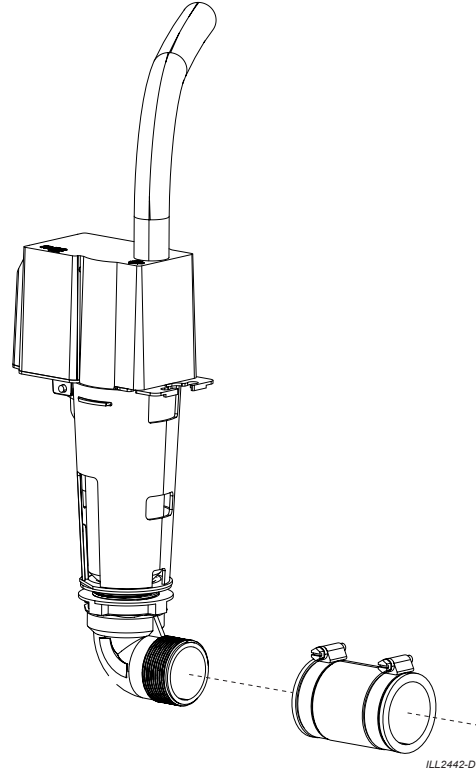

- Down Discharge 1.5" (40mm) BSP Male
- Down Discharge 1.5" (40mm) Flexible Coupling
- Rear Discharge 1.5" (40mm) BSP Male
- Rear Discharge 1.5" (40mm) Flexible Coupling

NOTE: Removable access panel should be re-assembled after drain line installation.

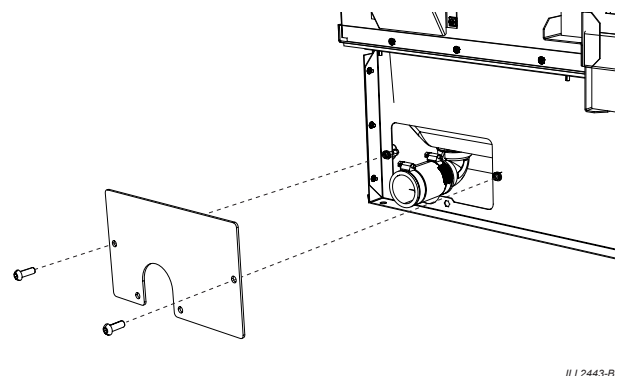

The correct drain system must be used. Water drained from the drain valve is high in salinity and must be carried away to a suitable discharge point on the building or property, in accordance with local regulations. **It is a requirement of Seeley International - Never drain the water directly onto the roof.**

INSTALLATION cont.

ELECTRICAL SUPPLY INSTALLATION (AUSTRALIA, EUROPE - 3PH 380-415V)

Please Note! There are specific models for regional specific voltages and frequencies **which are not interchangeable**, as these require differing component configurations that vary according to the supply frequency and voltage. Specifically, the main fan motor, 3 phase filter, transformer and pump are unique to the voltage/frequency of supply.

INSTALLATION OF THE COOLER MUST CONFORM TO LOCAL ELECTRICAL RULES, REGULATIONS AND STANDARDS.

It is a requirement of Seeley International that all coolers be wired with a dedicated circuit and circuit breaker to the distribution board, incorporating an isolation switch in the fixed wiring with all pole disconnection from the mains power in accordance with the local wiring rules.

Specification : 380 - 415V / 50 Hz / 3 Phase with Neutral / 3 Amps per phase

Climate Wizard requires 3-phase Neutral and Earth electrical power. If required, mains isolation switch is to be furnished by the contractor adjacent to the cooler - if mounting on the cooler cabinet, take care not to puncture the water reservoir. Mains power terminals are provided inside the electrical cabinet with glands provided for cable entry.

- C1 MOTOR CONTACTOR COIL**
- C2 FUSE T12.5A**
- C3 MAIN PCB POWER IN**
- C4 PUMP LINK**
- C5 DRAIN VALVE**
- C6 SALINITY PROBE**
- C7 MOTOR CONTROL SIGNAL**
- C8 WALL CONTROL**
- C9 WATER INLET SOLENOID**
- C10 CHLORINATOR LINK**
- C11 INTERFACE BOARD LINK**
- C12 NOT USED**
- C13 CHLORINATOR**
- C14* BMS COOL/VENT INPUT**
- C15* BMS ERROR SIGNAL OUTPUT**
- C16* BMS REMOTE ON/OFF INPUT**
- C17* BMS FAN SPEED INPUT 0-10Vdc**

***IMPORTANT** – Power supply input for BMS shall use a certified SELV power supply, and input/output connections to BMS shall be connected to SELV circuit only.

Interconnection wiring shall be separated by reinforced insulation to any live parts.

864761TEXT-D

CW-H10, H15 Models

380-415V / 3N~ / 60Hz SUPPLY

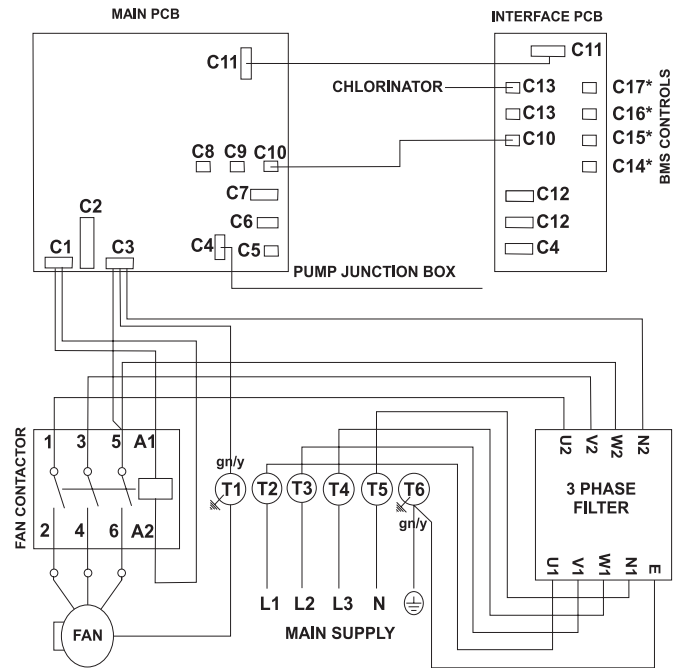

859651-F

CW-H15S, H15S Plus Models

380-415V / 3N~ / 50Hz SUPPLY

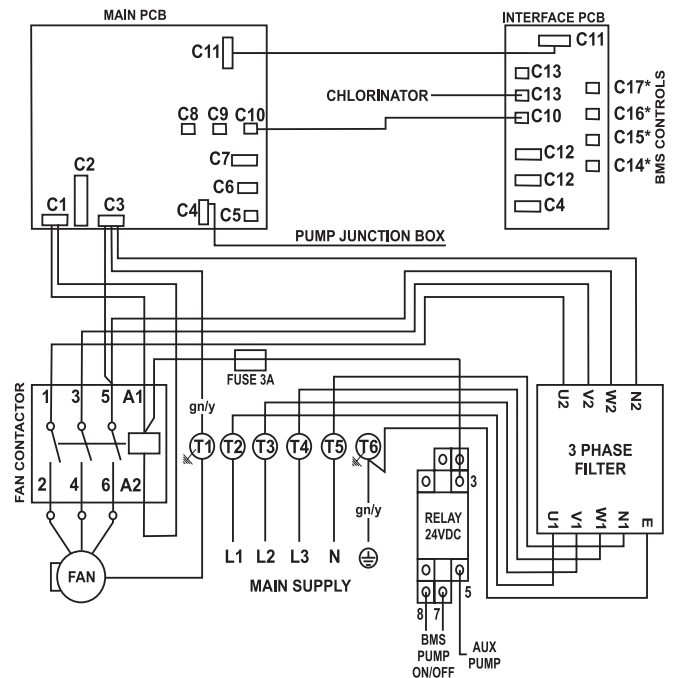

864761-D

INSTALLATION cont.

ELECTRICAL SUPPLY INSTALLATION (USA 3PH, 440-480V)

FOR CW-H15 AND CW-H15S ONLY

Please Note! There are specific models for regional specific voltages and frequencies **which are not interchangeable**, as these require differing component configurations that vary according to the supply frequency and voltage. Specifically, the main fan motor, 3 phase filter, transformer and pump are unique to the voltage/frequency of supply.

INSTALLATION OF THE COOLER MUST CONFORM TO LOCAL ELECTRICAL RULES, REGULATIONS AND STANDARDS.

It is a requirement of Seeley International that all Coolers be wired with a dedicated circuit and circuit breaker to the distribution board, incorporating an isolation switch in the fixed wiring with all pole disconnection from the mains power in accordance with the National Electric Code.

Specification : 380 - 480V / 60Hz / 3 Phase / 3 Amps per phase, 8.5 MCA, 15 MOPD*

Climate Wizard requires 3-phase (No Neutral) and Ground electrical power. If required, mains isolation switch is to be furnished by the contractor adjacent to the cooler - if mounting on the cooler cabinet, take care not to puncture the water reservoir. Mains power terminals are provided inside the electrical cabinet with glands provided for cable entry.

- C1 MOTOR CONTACTOR**
- C2 FUSE T12.5A**
- C3 MAIN PCB POWER IN**
- C4 PUMP LINK**
- C5 DRAIN VALVE**
- C6 SALINITY PROBE**
- C7 MOTOR SIGNAL**
- C8 WALL CONTROL**
- C9 INLET SOLENOID**
- C10 CHLORINATOR LINK**
- C11 INTERFACE BOARD LINK**
- C12 NOT USED**
- C13 CHLORINATOR**
- C14* BMS COOL/VENT INPUT**
- C15* BMS ERROR SIGNAL OUTPUT**
- C16* BMS REMOTE ON/OFF INPUT**
- C17* BMS FAN SPEED INPUT 0-10Vdc**

PHASE TO PHASE PRIMARY VOLTAGE	JUMPER BETWEEN
380V	31 - 38
400V	32 - 38
415V	31 - 37
440V	32 - 37
460V	32 - 36
480V	33 - 36

***IMPORTANT** – Power supply input for BMS shall use a certified SELV power supply, and input/output connections to BMS shall be connected to SELV circuit only.

Interconnection wiring shall be separated by reinforced insulation to any live parts.

865102TEXT-D

CW-H15 Models

440-480V / 3~ / 60Hz SUPPLY

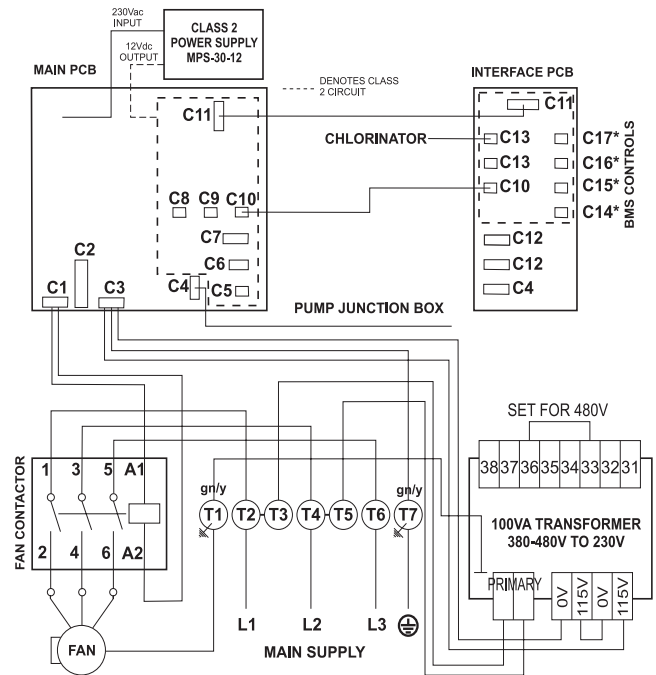

860312-E

CW-H15S, H15S Plus Models

440-480V / 3~ / 60Hz SUPPLY

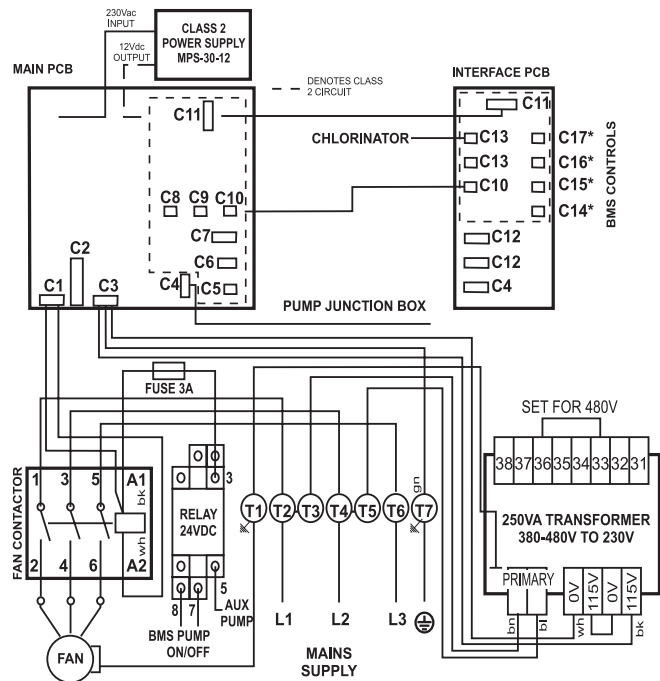

865102-D

INSTALLATION cont.

ELECTRICAL SUPPLY INSTALLATION (USA 3PH, 200 - 240V)

CW-H15, CW-H15S ONLY

Please Note! There are specific models for regional specific voltages and frequencies **which are not interchangeable**, as these require differing component configurations that vary according to the supply frequency and voltage. Specifically, the main fan motor, 3 phase filter, transformer and pump are unique to the voltage/frequency of supply.

INSTALLATION OF THE COOLER MUST CONFORM TO LOCAL ELECTRICAL CODES, REGULATIONS AND STANDARDS.

It is a requirement of Seeley International that all Coolers be wired with a dedicated circuit and circuit breaker to the distribution board, incorporating an isolation switch in the fixed wiring with all pole disconnection from the mains power in accordance with the National Electric Code.

Specification : 200 - 240V / 60Hz / 3 Phase / 6 Amps per phase, 14.5 MCA, 20 MOPD*

Climate Wizard requires 3-phase (No Neutral) and Ground electrical power. If required, mains isolation switch is to be furnished by the contractor adjacent to the cooler - if mounting on the cooler cabinet, take care not to puncture the water reservoir. Mains power terminals are provided inside the electrical cabinet with glands provided for cable entry.

- C1 MOTOR CONTACTOR COIL**
- C2 FUSE T12.5A**
- C3 MAIN PCB POWER IN**
- C4 PUMP LINK**
- C5 DRAIN VALVE**
- C6 SALINITY PROBE**
- C7 MOTOR CONTROL SIGNAL**
- C8 WALL CONTROL**
- C9 WATER INLET SOLENOID**
- C10 CHLORINATOR LINK**
- C11 INTERFACE BOARD LINK**
- C12 NOT USED**
- C13 CHLORINATOR**
- C14* BMS COOL/VENT INPUT**
- C15* BMS ERROR SIGNAL OUTPUT**
- C16* BMS REMOTE ON/OFF INPUT**
- C17* BMS FAN SPEED INPUT 0-10Vdc**

***IMPORTANT** – Power supply input for BMS shall use a certified SELV power supply, and input/output connections to BMS shall be connected to SELV circuit only.

Interconnection wiring shall be separated by reinforced insulation to any live parts.

CW-H15 Models

200-240V / 3~ / 60Hz SUPPLY

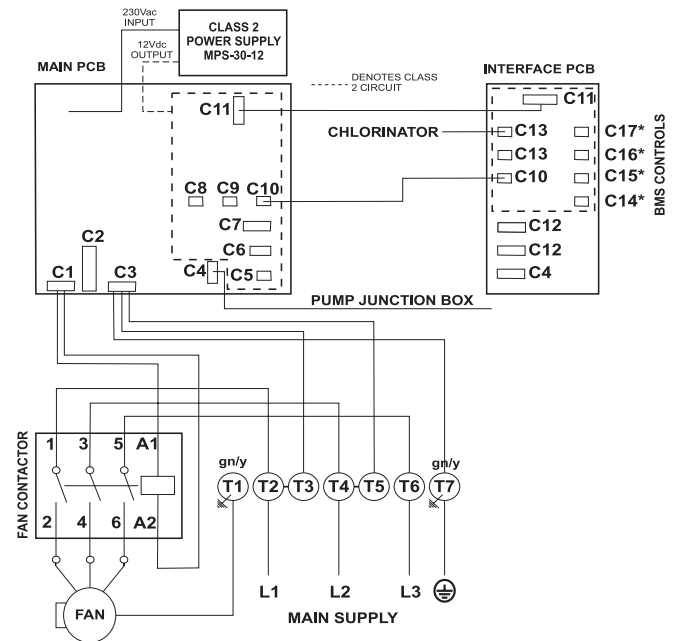

861371-D

CW-H15S, H15S Plus Models

200-240V / 3~ / 60Hz SUPPLY

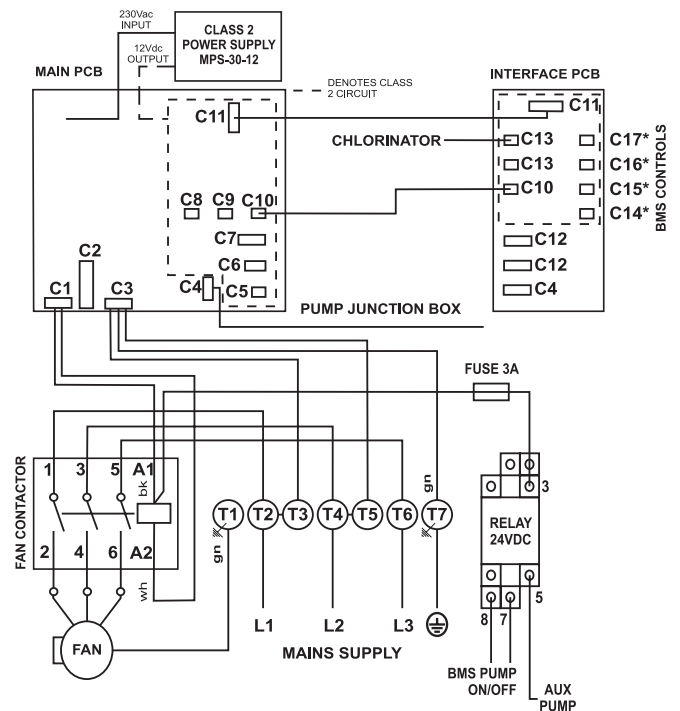

865164-D

865164TEXT-D

INSTALLATION cont.

ELECTRICAL SUPPLY INSTALLATION (USA 1PH, 200 - 240V)

CW-H15, CW-H15S ONLY

Please Note! There are specific models for regional specific voltages and frequencies **which are not interchangeable**, as these require differing component configurations that vary according to the supply frequency and voltage. Specifically, the main fan motor, 3 phase filter, transformer and pump are unique to the voltage/frequency of supply.

INSTALLATION OF THE COOLER MUST CONFORM TO LOCAL ELECTRICAL CODES, REGULATIONS AND STANDARDS.

It is a requirement of Seeley International that all Coolers be wired with a dedicated circuit and circuit breaker to the distribution board, incorporating an isolation switch in the fixed wiring with all pole disconnection from the mains power in accordance with the National Electric Code.

Specification : 200 - 240V / 60Hz / 1 Phase / 8 Amps per phase, 11.5 MCA, 15 MOPD*

Climate Wizard requires 1-phase (central tapped neutral) and Ground electrical power. If required, mains isolation switch is to be furnished by the contractor adjacent to the cooler - if mounting on the cooler cabinet, take care not to puncture the water reservoir. Mains power terminals are provided inside the electrical cabinet with glands provided for cable entry.

- C1 MOTOR CONTACTOR COIL**
- C2 FUSE T12.5A**
- C3 MAIN PCB POWER IN**
- C4 PUMP LINK**
- C5 DRAIN VALVE**
- C6 SALINITY PROBE**
- C7 MOTOR CONTROL SIGNAL**
- C8 WALL CONTROL**
- C9 WATER INLET SOLENOID**
- C10 CHLORINATOR LINK**
- C11 INTERFACE BOARD LINK**
- C12 NOT USED**
- C13 CHLORINATOR**
- C14* BMS COOL/VENT INPUT**
- C15* BMS ERROR SIGNAL OUTPUT**
- C16* BMS REMOTE ON/OFF INPUT**
- C17* BMS FAN SPEED INPUT 0-10Vdc**

***IMPORTANT** – Power supply input for BMS shall use a certified SELV power supply, and input/output connections to BMS shall be connected to SELV circuit only.

Interconnection wiring shall be separated by reinforced insulation to any live parts.

865171TEXT-C

CW-H15 Models

200-240V / 1~ / 60Hz SUPPLY

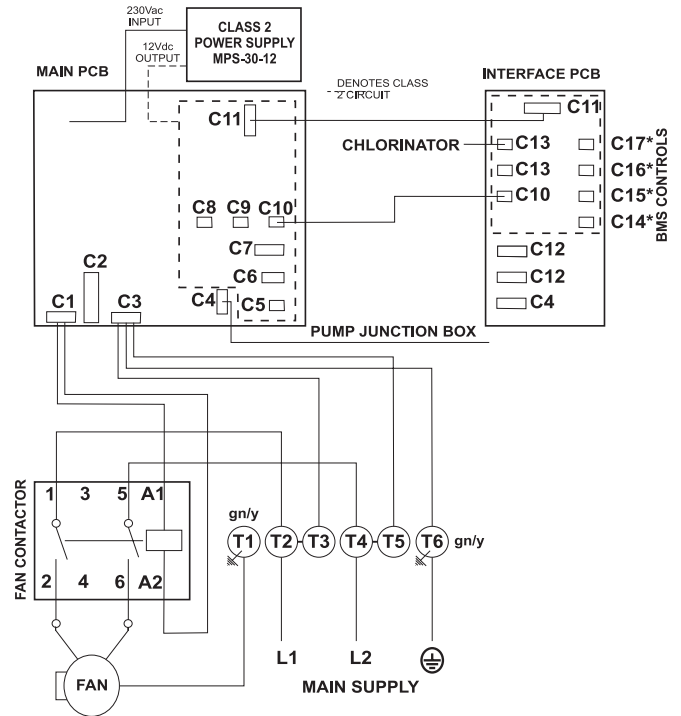

864730-C

CW-H15S, H15S Plus Models

200-240V / 1~ / 60Hz SUPPLY

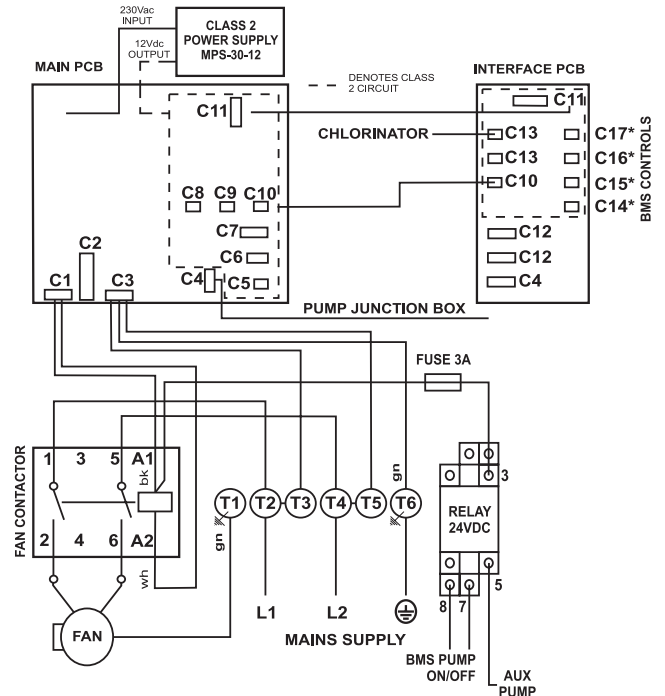

865171-C

INSTALLATION cont.

CLIMATE WIZARD SUPERCOOL INSTALLATION

CW-H15S coolers come with an additional pump to wet the direct evaporative cooling media. To control this pump a 24VDC power supply must be wired into the 24VDC relay inside the cooler's control box. A switch or a BMS control system must then be used to switch the pump on and off when required.

Note! It is recommended to only running the additional pump when the cooler is in COOL mode.

Note! The pump will only operate when the fan motor is running.

RELAY CONTROL METHOD 1: SWITCH

1. Connect a 24VDC power supply on to terminals 7&8 of the 24VDC Relay inside the Coolers Control Box.
2. Wire a switch in series to the one of the conductors to the 24VDC Relay.
3. Locate the Switch next to the Cooler's Wall Control.

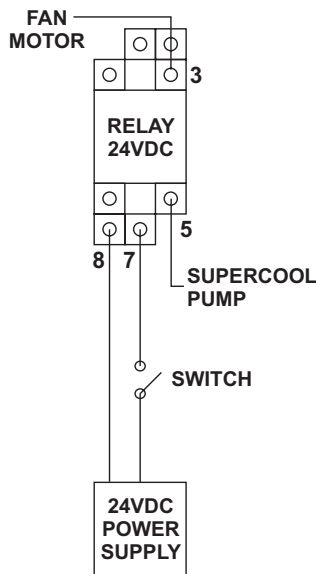

ILL2445-A

RELAY CONTROL METHOD 2: BMS

1. Connect a 24VDC power supply on to terminals 7&8 of the Relay inside the Coolers Control Box.
2. Place a relay switch in series with one of the conductors to the 24VDC Relay.
3. Link the relay switch to the BMS.

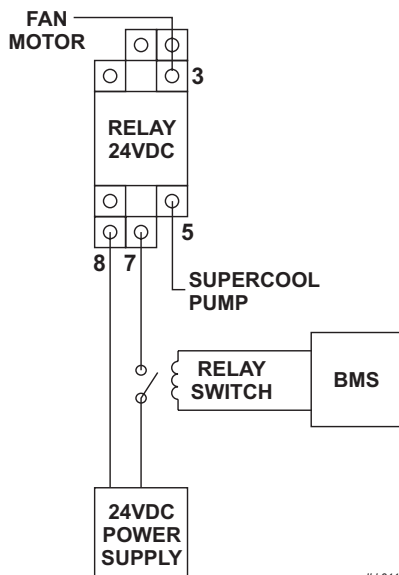

ILL2446-A

RELAY CONTROL METHOD 3: ALWAYS RUN

1. Remove lead for Supercool Pump from relay terminal 5 and attach to relay terminal 3.

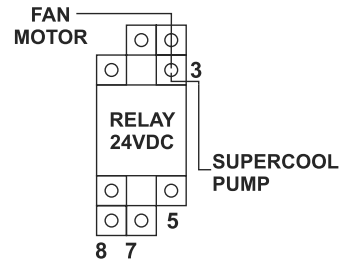

ILL2633-A

INSTALLATION cont.

CONTROL SCHEMES

OPTION 1 - LOCAL ZONE CONTROL WITH WALL CONTROL

Climate Wizard coolers are supplied from the factory with one (1) wall control and a 20m (65') control cable. This makes it possible for the cooler to be controlled independently and automatically from the zone to which it is delivering cool air. No additional equipment is required.

The wall control incorporates a thermostat that regulates fan speed to maintain indoor temperature to within + 0.5°C (+ 1°F) of the set temperature.

40m (130') control cables are also available on request (Part No. 094724). Maximum permissible cable length between the wall control and the cooler is 40m (130').

No interconnection between coolers to achieve 'group control' is possible.

OPTION 2 - BUILDING MANAGEMENT SYSTEM (BMS) INTERFACE

Climate Wizard coolers are supplied with an "Interface PCBA" in the electrical control enclosure.

This can be set up to control the Climate Wizard from EXTERNAL devices, such as PLCs or Building Management Systems and requires an independent low voltage power supply supplied by the installer.

Note! Even if a BMS or PLC is used, it is recommended to leave the Wall Control and cable within the control box for use during servicing.

Four (4) plug receptacles are provided.

Note! Connect the polarity as shown - incorrect polarity connection may damage the circuit board.

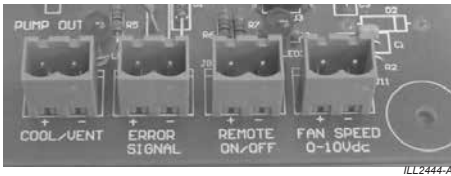

REMOTE ON-OFF (INPUT)

When a voltage (4-32VDC) is applied to the REMOTE ON-OFF receptacle, the Wall Control is ignored and cooler control is handed over to the BMS. If fitted, the Wall Control display will flash "Preparing to Start". Removing the voltage from the REMOTE ON-OFF terminal reverts control back to the Wall Control.

COOL/VENT (INPUT)

When BMS control is enabled via the REMOTE ON-OFF receptacle, applying a voltage (4-32VDC) to the COOL/VENT receptacle places the cooler in COOL Mode, otherwise the cooler defaults to VENT Mode.

FAN SPEED (INPUT)

When BMS control is enabled via the REMOTE ON-OFF receptacle, applying a 0-10VDC voltage to the FAN SPEED receptacle controls the fan speed, whereby 0V = OFF, 10V = Speed 10

ERROR SIGNAL (OUTPUT)

The error signal comprises of a single pole voltage free contact (solid state electronic, not mechanical relay) that closes under fault conditions. The contact is rated at 500mA at 32V Max. In order to use this signal an external voltage (4-32VDC) must be supplied that will then drive a relay coil or indicator lamp that does not exceed the above ratings.

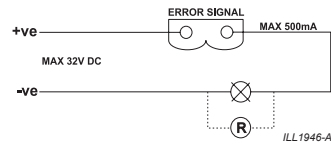

***IMPORTANT** – Power supply input for BMS shall use a certified SELV power supply, and input/output connections to BMS shall be connected to SELV circuit only.

Interconnection wiring shall be separated by reinforced insulation to any live parts.

865171TEXT-C

CW-H Wiring Schematic

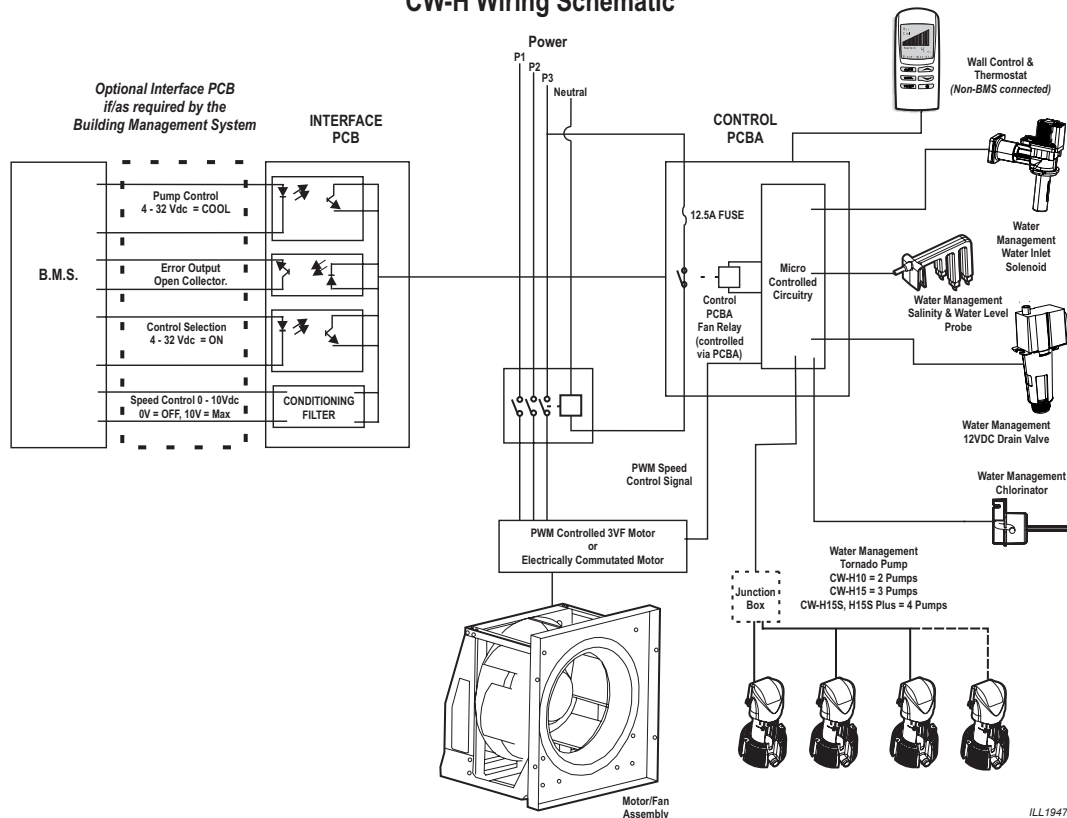

ILL1947-B

WALL CONTROL INSTALLATION

LOCATING THE WALL CONTROL

(Stand Alone & Supplementary Cooling)

The wall control should be placed approximately 1.5 m (5') above the floor, in the general area of the cooled zone.

For USA installations: To comply with the USA Disabilities Act, mount the wall control a maximum of 48" (1.22m) above the floor. Ensure a clear floor space below of minimum 30" x 48" high (0.76m x 1.22m high).

Placement of the Wall Control is critical for correct functioning of the inbuilt thermostat (incorporated in the wall control). The following points must be taken into consideration:

- Avoid direct sunlight exposure.
- Avoid mounting on external walls.
- Avoid mounting the wall control near heat sources such as room heaters, stoves and TV's.
- Do not locate in the direct airflow from the duct outlets.
- Do not locate in strong drafts or in dead spots such as corners and confined spaces.
- Always seal the cable entry hole in the wall. Hot air coming through the wall may interfere with the temperature measurement.

CAUTION! Always make sure there are no electrical cables, gas or water pipes, or the like, behind where you intend to drill.

FIXING THE WALL CONTROL BRACKET TO A PLASTERBOARD WALL

Use the bracket as a template.

1. Drill the 16mm (5/8") hole for the wall control cable
2. Drill the 5mm (3/16") holes for the wall plugs.
3. Insert the wall plugs into the holes. Align and screw the bracket into position using the supplied screws.

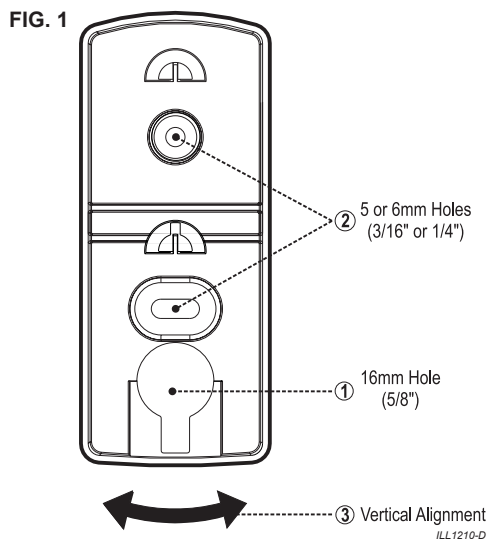

FIXING THE WALL CONTROL BRACKET TO A BRICK WALL

To mount the wall control bracket on a brick wall, follow the previous instructions (Fig 1) using the wall plugs and screws provided.

Note! that the wall plugs require 6mm (1/4") holes. Mount the wall control following the procedure in Fig 3.

Fitting the wall control to the mounting bracket

4. Pull the wall control cable through the larger hole and plug it into the wall control.
5. Feed the excess cable back into the hole and seal. Slide the wall control over the protruding bracket tabs.
6. Pull the wall control down so the bracket tabs engage and locate with the keyway slots on the rear.

FIG. 2

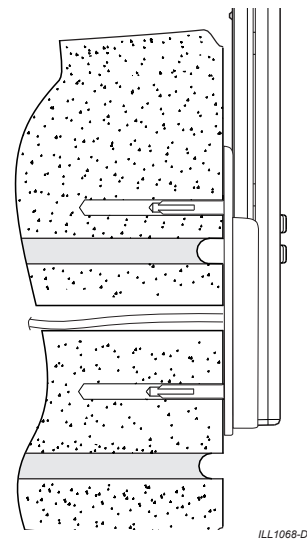

RUNNING THE WALL CONTROL CABLE TO THE WALL CONTROL

Using the loop on the end, draw the cable through the wall cavity to the hole made at the wall bracket. Carefully remove the tape from the cable loops and check that the plug has not been damaged. Connect the cable to the wall control and mount the wall control onto its bracket.

Important! Take care not to damage the cable or plug during this process. Always seal the cable entry hole.

FIG. 3

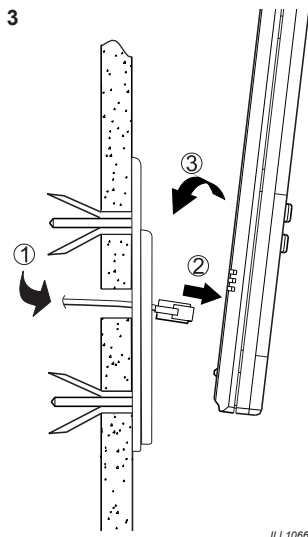

COMMISSIONING

WATER MANAGEMENT SYSTEM

Tank (reservoir) drain valve control

- When power switched on to the cooler, the Drain Valve opens to check operation of the Valve.
- Drain Valve remains open until COOL mode selected.
- When COOL mode selected the Drain valve shuts.
- Drain Valve opens when:
 - COOL mode switched OFF and tank drain delay is activated. Drain Valve remains open until next COOL mode activated. See "Parameters" below for time delay options
 - Salinity Control demands the tank (reservoir) to be drained. (Refer to the Salinity Control section following).

Inlet solenoid valve control - water

- Opens 9 seconds after COOL mode starts (in order to give Drain Valve time to shut).
- Opens if water level is below the bottom probe.
- Remains open until water level reaches top probe.
- Will also open at anytime that Salinity Control demands fresh water.

Pre-wet cycle

(Pre-wet runs the pumps for 3 minutes to ensure the Cores are fully saturated when COOL mode is activated).

- Default setting - Pre-wet cycle enabled
- Pre-wet duration 3 minutes
- PreWet always occurs when COOL mode is selected after a Mains power interruption.
If COOL mode is selected and the Mains power has not been interrupted, then a PreWet will occur if the Drain has not been activated since the last time COOL mode was selected.
- During pre-wet cycle the fan runs on low speed.
- After Pre-wet, fan will resume running at Wall Control speed setting.

Pump control

- When COOL selected, fan and pump will start 30 seconds after water level has reached the bottom probe
- After a Pre-wet the pump then cycles continuously:
ON for 1 minute
OFF for 8 minutes
- Fan speed is slowed during watering cycles to prevent water take-off from the cores entering either the exhaust air stream or the cooled air stream and the building ducting (slowing only occurs if the fan was running above the safe watering speed limit).

Salinity Control

- Water Conductivity sensing:
 - Water conductivity is updated after every normal pump ON-OFF cycle.
 - When conductivity exceeds the upper set point the water inlet solenoid valve is opened to allow fresh water entry.
 - If water reaches top probe, but conductivity is still too high, a drain cycle starts.
 - Drain valve opens until water level falls below bottom probe, then valve closes immediately, and inlet solenoid valve opens to refill the reservoir.
 - Will sense conductivity down to 9 μ S (about 4ppm) (ie: rain water).

Water Usage sensing:

- Number of times that reservoir is filled from bottom probe to top probe is counted. When this count reaches 8, a drain

cycle is initiated.

- Drain valve opens until water level falls below bottom probe, then valve closes immediately, and inlet solenoid valve opens to refill the reservoir.
- Pumps enabled to run at any time during the salinity drain cycle.

Chlorinator Control

The Chlorinator is a pair of specially treated plates. When energised and submerged in water, electrical current flows between them, generating chlorine. Chlorine is known to kill bacteria in water supplies and the Climate Wizard Chlorination system is designed to minimise bacteria levels within the cooler.





- Chlorinators are active at all times that the cooler is in COOL mode, AND the water level is above the bottom probe, AND the salinity control is not sensing (50 seconds in every 60 seconds) AND the water conductivity is $>1500\mu$ S/cm.
- In the event that the water conductivity is $<1500\mu$ S/cm for an extended period of time, a 24 hour clean tank drain cycle will commence.

COMMISSIONING cont.

TESTING THE COOLER

Once you are satisfied that the Cooler is installed and commissioned correctly, run it to ensure that everything is working as it should.

Check Fan Operation



Press the  button to start the cooler. Press the  button to toggle into Vent mode. Use the  and  buttons to increase and decrease the fan speed. Confirm the cooler runs quietly and is free of excessive vibration.

Check Water Management System Operation

Press the  button to toggle into Cool mode. Confirm the following sequence occurs;

- Fan speed drops to idle. **Note:** Fan speed will remain at idle regardless of Wall Control/BMS setting.
- Drain valve shuts.
- After a 9 second delay, the inlet solenoid opens, allowing water into the cooler.
- Once water reaches the top probe position the inlet solenoid closes. Depending upon local water pressure, this may take several minutes.
- Pre-wet cycle starts. Pumps (excluding Supercool Pump) run for 3 minutes.
- After pre-wet cycle ends, fan speed control returns to the Wall Control/BMS setting.















Check Drain Valve Operation

Turn the cooler off. Press the  and  buttons together until “dr” appears on the Wall Control. Confirm the drain valve opens and water drains from the reservoir.

Check the all water fittings and pipes, making sure there are no leaks.

CHANGING CONTROL PARAMETERS

To enter Parameter mode using a Wall Control, the following process must be carried out within 4 minutes of power being applied to the cooler. If unsure of time since the last Power “ON”, remove Power to the cooler (Isolator Switch or Circuit Breaker) for a minimum of 6 seconds so the mode can be entered.

1. While wall control is OFF, push and hold “” for minimum 3 seconds. After 3 seconds while still holding “” button press the “” button. (If “” button is pressed before 3 seconds, nothing will be on the display. If “” button, is continued to be held subsequent presses of “” button will allow access).
2. When parameter mode has been entered, screen will display “A1” and “Param”. Pressing “” or “” buttons will scroll through parameters “A1” to “B3” (Refer to table below for factory settings).
3. To view parameter number set in wall control press “” momentarily. Figure “A#” on screen will change to number set, and “Param” will change to “value”.
4. To alter the “value” of selected parameter press “” or “”. Numbers will change to show different values parameter can be set to.
5. To store the selected value, press “”. Screen will go blank momentarily as wall control stores parameter change, and returns screen to “A#” and “Param”.
6. To exit parameter mode or escape from an alteration without storing a change press “” button instead of “” button. Remember, once step 5 has been carried out, new parameter change is permanent until again altered.
7. If no buttons are pushed on wall control, after 3 minutes screen will reset to “OFF” state. Procedure to enter parameter mode must be re-initiated.

Parameters

No.	Description	Value
A1	Water salinity control method: - Conductivity measuring 00* - Counts low to high probe fills	00* 01
A2	Not applicable to Climate Wizard	
A3	Pre-wet control: - No pre-wet - Pre-wet	00 01*
A4	Wall Control back light: - Backlight 'OFF' - Backlight 'ON'	00* 01
A5	Conductivity set point: - Normal conductivity - 4275 µS/cm - Low conductivity - 2305 µS/cm	00* 01
A6	Tank (reservoir) drain delay: - Instant drain at COOL off - Drain 3 hours after COOL off - Drain 12 hours after COOL off - Drain 3 days after COOL off	00 01 02* 03
A7	Auto re-start after Power failure: - Requires manual re-start when power OFF - Auto restart	00 01*
A8	Temperature units: - Display °C - Display °F	00* 01

* = Default Value

COMMISSIONING cont.

SETTING THE AIR DISCHARGE DAMPER

AIR FLOW BALANCING

In order for the Climate Wizard to produce cool air it is mandatory that some of the inlet air is forced to return through the heat exchanger cores and be exhausted to atmosphere. Therefore only a proportion of the total inlet air is delivered into the cooled zone.

THIS PROPORTION IS CRITICAL TO ACHIEVING SATISFACTORY PERFORMANCE.

The supply air transition is equipped with a set of dampers that can be adjusted to 'balance' the proportion of supply and exhaust air streams. Damper position is control through a lever with locking screw located underneath the supply air transition. The damper will need to be adjusted during Commissioning depending on the resistance of the duct system.

There is also a hole in the right hand side of the supply air transition suitable for manometer tubes for measuring pressure.

NOTE: Pressure measuring should be carried out using an accurate instrument, either electronic or "inclined tube manometer". **DO NOT GUESS.**

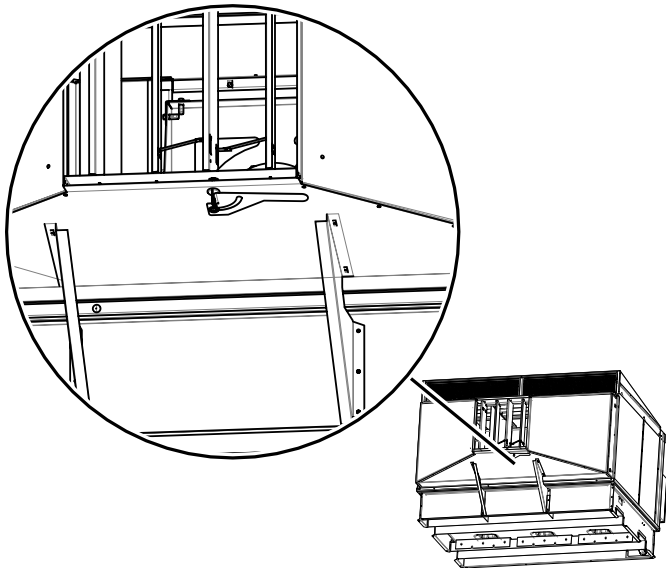

ILL2447-A

1. Fit Climate Wizard Inlet Air Filters and Cowling (if required).
2. Connect all external supply and exhaust ductwork.
3. Fully open all supply air outlets in the entire ductwork system.
4. Cold Front or Supplementary Cooling - Ensure all main Air Conditioning plant fans are running at full speed - consult with Building Manager and/or Air Conditioning contractor.
5. Start the Climate Wizard in MANUAL and COOL modes on full speed, allowing the pre-wet cycle to complete.
6. Adjust the Climate Wizard damper until the pressure in the transition stabilises as follows:
 - a.CW-H10: 200 Pa (0.80 in wg static)
 - b.CW-H15: 190 Pa (0.76 in wg static)
 - c.CW-H15S: 190 Pa (0.76 in wg static)
 - d.CW-H15S Plus: 180 Pa (0.72 in wg static)

Proceed to balance the external duct and outlets in your usual manner.

7. Check and if necessary re-adjust the Climate Wizard damper back to the above values.
8. Lock the damper in its final position.

INSTALLATION CHECKLIST

Owner Name: **Telephone:**

Address:
.....

Dealer: **Installer:**

Date Installed: **Model No:**

Serial No:

INSTALLATION

- The cooler is adequately supported, secure and level.
- The water pipes were flushed of any foreign materials before connection the cooler was made.
- The owner has been instructed on how to isolate the water to the system in case of emergency.
- Water pressure reducing valve fitted if required.
- The water is connected with no leaks at fittings.
- Water pipes are correctly saddled as per the applicable plumbing regulations.
- The drain water does not discharge onto the roof surface.
- The power supply adheres to all local and national regulations and is wired back to the distribution board on its own separate circuit.
- All cables have been correctly connected to the control boxes (i.e. power supply, control cable)
- The owner has been instructed how they can electrically isolate the cooler at the meter box in case of an emergency.
- All ducts are fixed correctly and there are no air leaks.
- The system has been run from the customer's wall control and all functions work correctly.
- The air balance for all outlets has been adjusted to the customer's satisfaction.
- The customer has been shown how to operate the system.
- All the installation rubbish has been removed and, if applicable, any property damage repaired.

COMMISSIONING

- Visual inspection completed no damage.
- Electrical supply to cooler OK.
- Inlet filter installed correct way round. Observe Airflow direction arrows.
- Cooler internal water levels checked.
- Chlorinator fully submerged at low water level.
- Outlet drain connected YES/NO. Adaptor drain elbow fitted YES/NO.
- Exhaust Cap fitted - see Page 10. CW-H15S Plus Only
- Air flow balancing set discharge damper (Refer "COMMISSIONING" Page 24). Value = _____ kPa
- Cooler function test with wall control function check OK.
- BMS control test (where applicable) OK.

Signed by Installer:

Commissioning Engineer:

Dated:

Date:

OPERATING INSTRUCTIONS

WALL CONTROL

TURNING THE COOLER ON

The wall control can be switched on and off by pressing the  button. The wall control will remember the previous setting it was in when the cooler was last used.

PREPARING TO START

Whenever you select AUTO mode or COOL in MANUAL mode, the cooler will take a few minutes to start as it fills with water and saturates the cooling cores. The time will be decreased if the reservoir is full or the cooler has only recently been turned OFF.

MANUAL MODE

With the wall control switched ON, press the  button until MAN is shown on the display.

(Note!) The Wall control display will default to show temperature in °C (Celcius). If °F (Fahrenheit) are desired, refer to Page 23 for instructions on how to change the A8 Temperature Unit parameter.

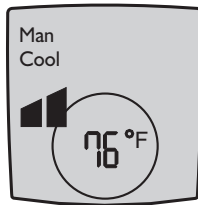

ILL1709-A

You may then press the  button to switch between COOL and VENT. (VENT = fresh air being delivered but not cooled).

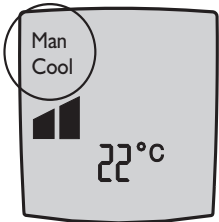

Once COOL or VENT has been selected, the wall control will maintain a constant fan speed. This is indicated by the bar graph shown on the display.

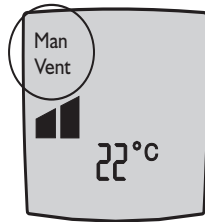

ILL1707-A







ILL1708-A

To increase or decrease the fan speed required, press either the  or  button.

AUTO MODE

To select the AUTO mode press the  button until AUTO is shown on the display.

In AUTO mode the cooler will remember the last setting used and try to achieve this. It may vary depending on the day's conditions. Pressing  or  button will change the displayed 'room' temperature to a flashing 'setpoint' temperature. This 'setpoint' temperature can be adjusted by pressing the  or  buttons whilst the 'setpoint' temperature is being displayed.

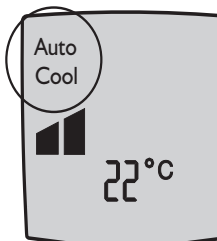









ILL1710-A

DELAYED START AND STOP

The cooler can be programmed to start at a specific time or stop at a specific time.

The delayed start time can only be programmed when the cooler is OFF. To program the cooler to Start in a certain amount of hours use the following sequence:









Programming in manual mode

1. Press the  button.
2. Press the  button until "MAN" is displayed on the screen.
3. Press the  or  button until the desired fan speed is displayed by the bars in the middle of the screen.
4. Press the  button to set either COOL or VENT.
5. Press the  button and the 'starts in' time will start flashing. Use the  and  buttons to select the desired time.
6. Press  again.



ILL1711-A

Programming in auto mode

1. Press the  button.
2. Press the  button until flashing AUTO and set temperature are displayed. Press the  or  button until the desired temperature is displayed on the screen.
3. Press the  button and the 'starts in' time will start flashing. Use the  or  button to select the hour.
4. Press  again.

The delayed stop time can only be programmed when the cooler is ON. To program the delayed time in which you want the cooler to stop use the following sequence:

Select the  button and the 'stops in' time will start flashing.

Use the  and  buttons to select the desired off time.

1. Press  again.

Note! Delayed start and stop times must be re-set every day that they are required.

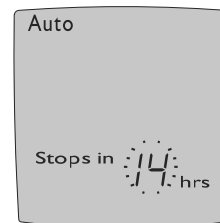

ILL1119-B

OPERATING INSTRUCTIONS

cont.

SERVICE MODE

When a fault has been recognized by the wall control the word "Service" flashes on the screen. When "Service" is displayed it maybe necessary for you to contact your Service Agent. However, before doing so, turn the wall control OFF. You will notice a number flashing at the bottom of the screen. This number indicates the code for the fault that has occurred.

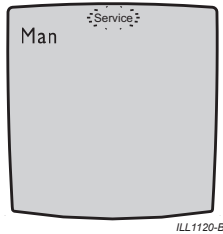

Please write this number down, then push the  button to turn the cooler back on. If after a short time "Service" is again shown on the display, turn the wall control OFF and check if the flashing number is the same. If it is, check the following possible problems. However, we do recommend that any checks be carried out by an authorised dealer or service agent.

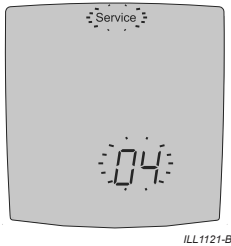

If '02' or '03' is displayed



1. Check that your local water authority has not temporarily disconnected the water in your area.
2. Check that the water supply tap to the cooler is turned on.

If '04' is displayed

1. Check that the drain is not blocked.

If these do not fix the problem then contact your Service Agent. You will need to quote the flashing number that you wrote down.

DRAIN MODE (COOLER SWITCHED OFF)

Pressing the  and  buttons at the same time for 2 seconds will open the drain valve and empty the water in the reservoir. The wall control will display "dr" on the screen. Draining the water will leave the reservoir clean and dry until it is next used. This function is not mandatory because the water will be drained from the reservoir automatically after a pre-set time delay, in order to keep the cooler healthy and dry until it is used again next time.

POWER OUTAGES

If the power supply fails for less than 5 seconds the cooler will retain its current settings. That is, it will stop for the time the power is off but resume operation when the power comes back on again.

If the power fails for more than 5 seconds the cooler will automatically turn itself off.

According to the chosen parameter (A7), if value 00 is set, when power comes back on, the cooler will not resume operation. You will have to re-start it at the wall control.

If parameter 01 is set, the cooler will re-start again when power is restored.

MAINTENANCE INSTRUCTIONS

QUARTERLY INSPECTION PROCEDURES

NOTE! All maintenance must be done by a trained, licensed technician, in accordance with National and Local Regulations (eg AS/NZS 3666.2 etc). Some activities may require 2 persons to comply with local Health and Safety regulations.

The following instructions assume the cooler is controlled with the supplied Wall Control. It is recommended that the cooler is disconnected from any Building Management System (BMS) prior to a service. Liaise with the Building Manager prior to starting a service.

1. Drain the cooler reservoir by initiating a manual drain (refer "DRAIN MODE (Cooler switched OFF)" on page 29).
2. Isolate and lockout the power supply to the cooler.
3. Turn off the water supply.
4. Remove the service access panels from both sides of the cooler.
5. Clean the Pump Strainers & Impellers (refer "Cleaning Pump Strainers & Impellers" on page 30).
6. Clean the Chlorinator Blades (refer "Chlorinator Maintenance AND Replacement" on page 31).
7. Clean the Water Management Probe (refer "Water Management Probe Maintenance AND Replacement" on page 31).
8. Clean the Water Reservoir (refer "Cleaning the Water Reservoir (Tank)" on page 32).
9. Clean or Replace the Inlet Air Filters (if fitted) (refer "Cleaning or Replacing Inlet Air Filters" on page 33).
10. Turn on the power and water supply.
11. Complete the Cooler Commissioning sequence (refer "INSTALLATION CHECKLIST" on page 27).
12. Re-fit the service access panel to both sides of the cooler. Apply a liberal coat of anti-seize paste to the screw threads prior to fitment.

SIDE VIEW - LHS

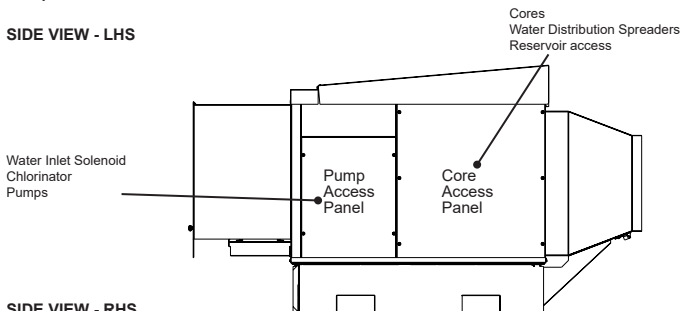

SIDE VIEW - RHS

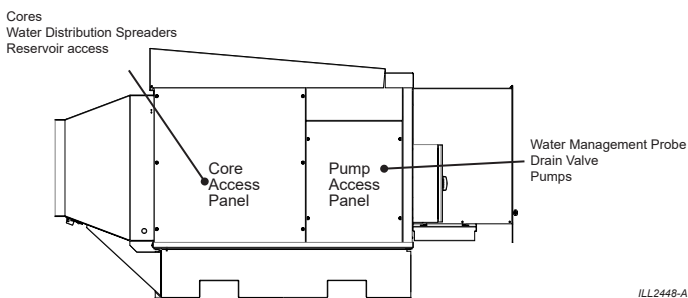

REAR VIEW

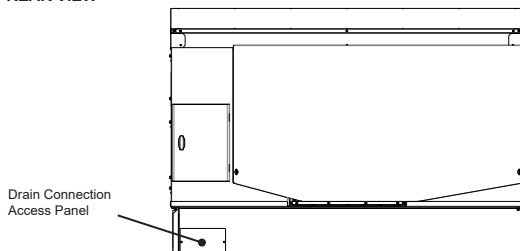

ILL2448-A

PUMP MAINTENANCE & REPLACEMENT

Quantities and locations of pumps for each model.

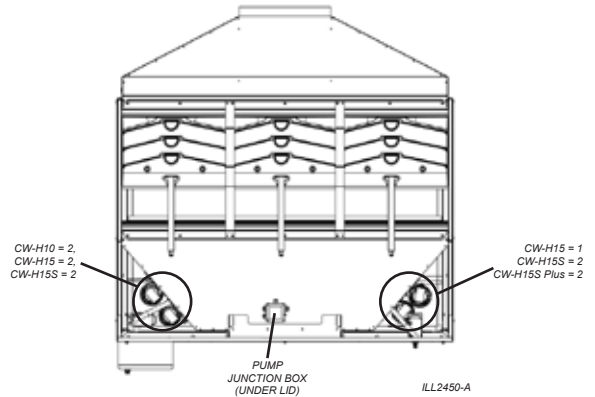

CHANGING PUMPS

1. Cut the cable tie securing the pump leads and remove the 2 screws securing the pump bracket to the wall of the cooler.
2. Disconnect the plumbing hose from the spigot at the pump base.
3. Remove the pump assembly from the cooler cabinet.
4. To remove pump from the strainer, press the release button on the strainer, twist the pump body clock-wise with button depressed and lift the pump body out of the strainer base. Note the orientation prior to removal.
5. Inspect and clean the pump strainer and impellor housing. Remove any solids or residues from the strainer slots or around the impellor with a soft brush.
6. Re-assemble in the reverse order, use a new cable tie to tidy and secure all the cables again.

Pump Replacement Only

Pumps are connected in parallel via a junction box located below the cooler lid back panel.

Trace the pump cable back to the pump junction box to identify the correct cable gland and terminal junctions.

Replicate the pump basket orientation with the pump being removed.

Unscrew the 2 screws securing the pump to the bracket and refit to the new pump.

CLEANING PUMP STRAINERS & IMPELLORS

1. Cut the cable tie securing the pump lead and remove the 2 screws securing the pump bracket to the wall of the cooler.
2. Disconnect the plumbing hose from the spigot at the pump base. Remove the pump assembly from the cooler cabinet. To remove pump from the strainer, press the release button on the strainer, twist the pump body clock-wise with button depressed, lift the pump body out of the strainer base.
3. Inspect and clean the pump strainer and impellor housing. Remove any solids or residues from the strainer slots or around the impellor with a soft brush.
4. Re-assemble in the reverse order, use a new cable tie to tidy and secure all the cables again.

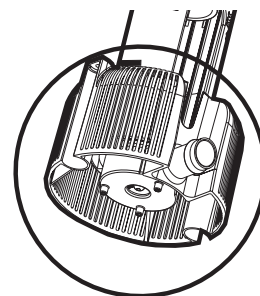

ILL1956-A

MAINTENANCE INSTRUCTIONS cont.

CHLORINATOR MAINTENANCE AND REPLACEMENT

SIDE VIEW - LHS

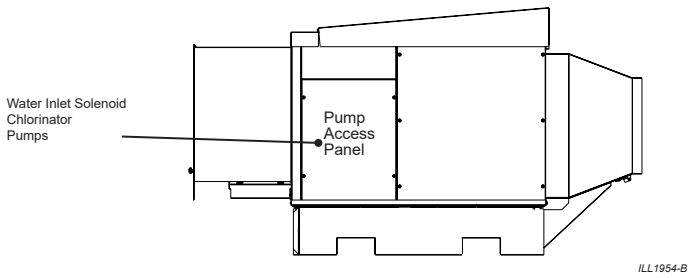

The chlorinator is fitted to a bracket located underneath the water inlet solenoid valve. The chlorinator and bracket can be removed together. To remove, detach the water hose and unscrew the bracket from the cooler body.

1. Wash or hose the chlorinator in clean water (hot water if possible).
2. Immerse the chlorinator in a plastic container with 5% phosphoric acid solution for at least 10 minutes. Be sure to clean the inner surfaces of the chlorinator blades.
3. Rinse with fresh water & reassemble chlorinator. Ensure chlorinator spacing clip is in place.

IMPORTANT - ENSURE THE CHLORINATOR AND 4-WAY DISTRIBUTOR SIT PARALLEL TO THE BRACKET AS SHOWN.

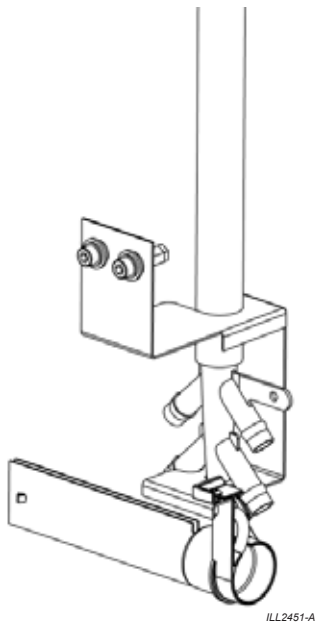

Chlorinator Replacement Only

Unplug the chlorinator lead from the main PCBA, (refer to the wiring diagram on the control box door for the plug point location), remove the lead from the cable gland at the base of the control box and pull through the rubber gland mounted below the control box. Use the old cable to pull the new cable to the opposite side of the cooler.

WATER MANAGEMENT PROBE MAINTENANCE AND REPLACEMENT

SIDE VIEW - RHS

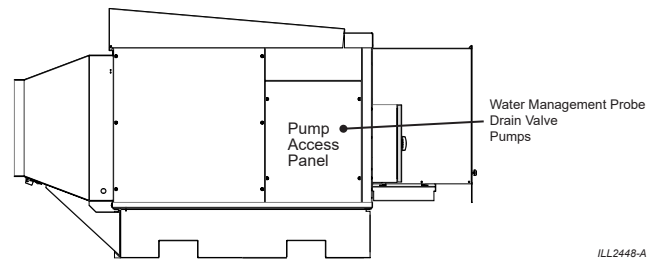

Cleaning or Replacing the Water Management Probe

1. Open the pump access panel. Cut the cable tie securing the probe lead to the pump hose.
2. Unclip the probe from the bracket, pull the lead through the opening in the bracket and pull the probe out from the enclosure (there is sufficient lead length to clear the pump enclosure). Remove the small plastic shrouds from the first and third pins.
3. Clean the pins by wiping the contact surfaces with a soft cloth - do NOT use abrasives.
4. Check the probe pin resistances using a multi-meter (refer figure and wiring diagram - you'll need to unplug the probe lead from the main PCB to do this).

Clean the water level probes by wiping the contact surfaces with a soft cloth.

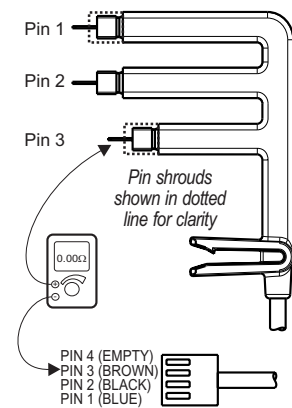

Resistance should be 0-0.5 ohms. A reading of 5 ohms or greater indicates a faulty probe. Check for shorts between pins: There should be an open circuit.

5. Refit the shrouds over pins 1 & 3. Refit the probe to the bracket, making sure the clip is fully engaged and square (the clip makes a "click" sound when properly engaged).

To remove and replace the water management probe,

1. Unclip the probe from the mounting bracket, unplug the probe lead from the main PCB, remove the lead from the cable gland at the base of the control box, pull the lead through the rubber gland mounted below the control box from the access panel opening.
2. Refit the assembly. Use a new cable tie to tidy and secure all the cables again and re-assemble.

MAINTENANCE INSTRUCTIONS cont.

DRAIN VALVE MAINTENANCE AND REPLACEMENT

SIDE VIEW - RHS

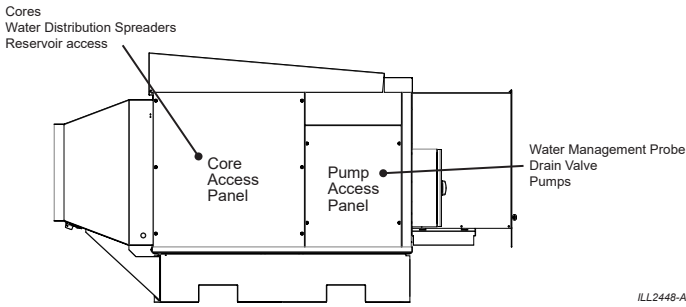

ILL2448-A

No regular maintenance of the drain valve is required; however it is sometimes necessary to remove the drain valve fully during tank flushing.

Drain Valve Replacement Only

1. Unplug the drain valve lead from the main PCBA, (refer to the wiring diagram on the control box door for the plug point location), remove the lead from the cable gland at the base of the control box and pull through the rubber gland mounted below the control box.
2. Remove the breather hose from the top of the Drain Valve cap.
3. Remove any drain fittings from the bottom of the Drain Valve.
4. Undo the drain valve nut on the bottom of the reservoir and lift the drain valve out of the cooler.
5. When replacing, make sure that the O-Ring (2) and Retainer (3) is fitted to the drain valve thread before replacing the valve back into the reservoir. Screw the nut (4) up tightly by hand through the drain valve access panel. **Do not overtighten the nut.**
6. Re-fit the breather hose (6) into the side panel hole.
7. Re-fit the drain fittings to the bottom of the Drain Valve.

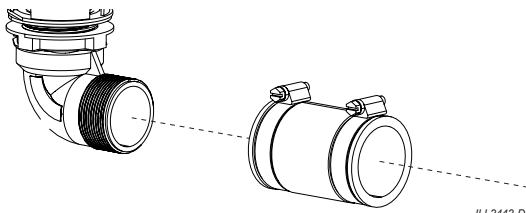

ILL2442-D

8. Run the new drain valve cable through to the control box and connect to the PCBA.

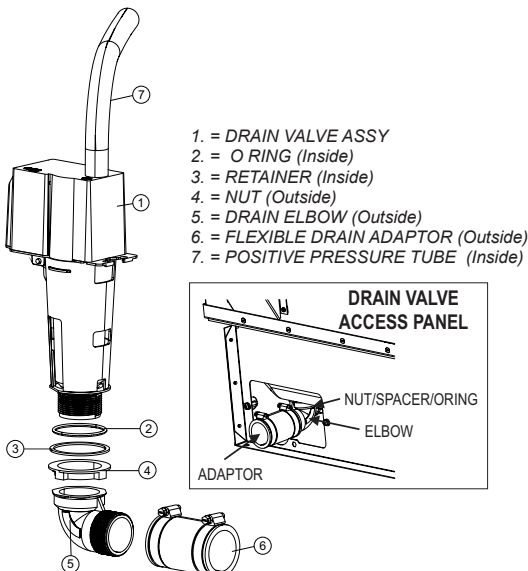

- 1. = DRAIN VALVE ASSY
- 2. = O RING (Inside)
- 3. = RETAINER (Inside)
- 4. = NUT (Outside)
- 5. = DRAIN ELBOW (Outside)
- 6. = FLEXIBLE DRAIN ADAPTOR (Outside)
- 7. = POSITIVE PRESSURE TUBE (Inside)

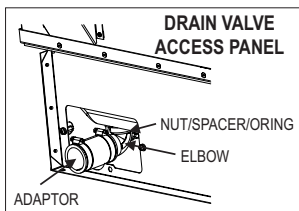

ILL2453-A

CLEANING THE WATER RESERVOIR (TANK)

Flushing of the Water Reservoir is best achieved with the pumps/chlorinator and water management probe removed. In instances of large amounts of solid debris, it is also recommended to remove the drain valve.

Use a water hose or low-pressure cleaner to flush all debris down the reservoir drain. After flushing wipe the bottom of the reservoir thoroughly using a wet cloth or brush.

SOLENOID VALVE MAINTENANCE AND REPLACEMENT

No regular maintenance of the solenoid valve is required.

SIDE VIEW - LHS

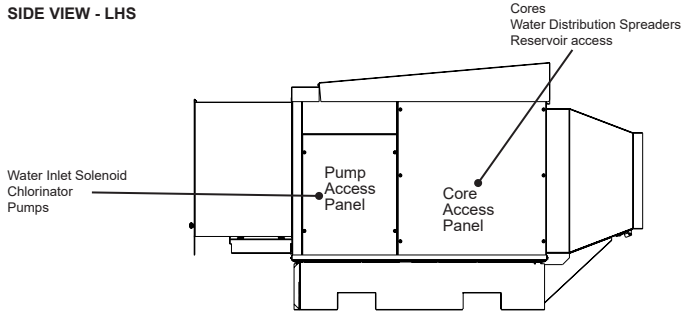

ILL1954-B

Solenoid Valve Replacement Only

1. Turn off the water supply.
2. Remove the breather hose from and unclip the solenoid cover (B).
3. Remove the outlet hose from the bottom of the solenoid valve.
4. Undo and remove the water inlet nipple (D) from the old solenoid.
5. Fit the new solenoid to the bracket (C) with a new water inlet nipple (D) and o-rings (E) and (F).
6. Unplug the old solenoid lead from the main PCBA, (refer to the wiring diagram on the control box door for the plug point location), remove the lead from the cable gland at the base of the control box and pull through the rubber gland mounted below the control box. Use the old cable to pull the new cable to the opposite side of the cooler. Plug the new solenoid into the PCBA.
7. Re-attach the outlet hose, ensuring there is a 10mm (3/8") gap between the top of the hose and the top of the slot in the solenoid - this is to prevent a vacuum being created (refer diagram below).
8. Re-fit the breather hose and solenoid cover (B).

- A SOLENOID VALVE, NYMET BRAND, 12VDC, 1000KPA
- B SOLENOID COVER
- C SOLENOID COVER BRACKET
- D FITTING 1/2" BSP
- E O-RING 19MM ID
- F O-RING 25MM ID
- G RIVET 1/8" (X4)
- H BLANKING GROMMET 12MM (NOT SHOWN)
- I PRESSURE HOSE 300MM (NOT SHOWN)

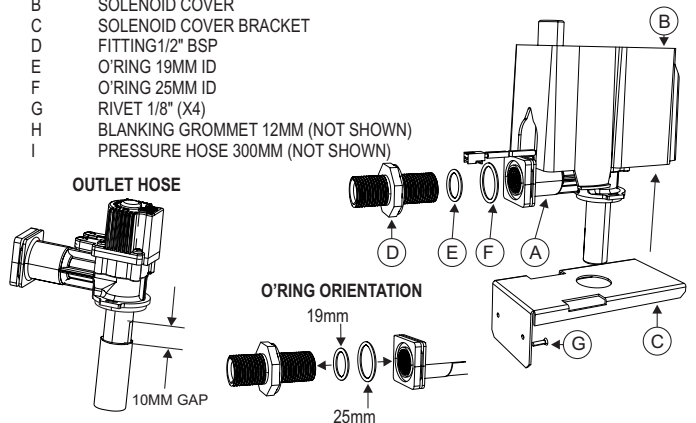

ILL2454-A

MAINTENANCE INSTRUCTIONS cont.

CLEANING OR REPLACING INLET AIR FILTERS

The Inlet Air Filters should be and replaced as soon as the airflow through the filters is restricted by dust or contaminants. The frequency of changing the Inlet Air Filters is dependent on the air quality at the site

Replacement Inlet Air Filters are available from SI Service Agents and Climate Wizard Distributors. If alternative air filters are supplied, they should be to EN779 G4 or ASHRAE 52.2 MERV8 standards as a minimum.

When ordering replacement Inlet Air Filters ensure the correct sizes/part number for your cooler are selected from the tables below.

Model	CW-H10	CW-H15, H15S, H15S Plus
Replacement Kit P/No.	120423	120393
Kit Contents	1 * 24x24x2in (594x594x45mm) 2 * 24x12x2in (594x291x45mm)	1 * 24x24x2in (594x594x45mm) 3 * 24x12x2in (594x291x45mm)

To access the Inlet Air Filters, the front panel of the Air Filter Cowling must be removed by releasing x2 quarter-turn fasteners.

The Inlet Air Filters slide in and out of the Air Filter Frame. When fitting, use the air flow direction sticker on the side of the filter to ensure the correct orientation.

The smaller side and bottom filters slide into the filter frame. To fit the larger front filter, locate the top edge of the filter under the top brackets and lift to engage the filter inside them. Allow the filter to drop, to engage the 2 bottom brackets at the bottom of the frame.

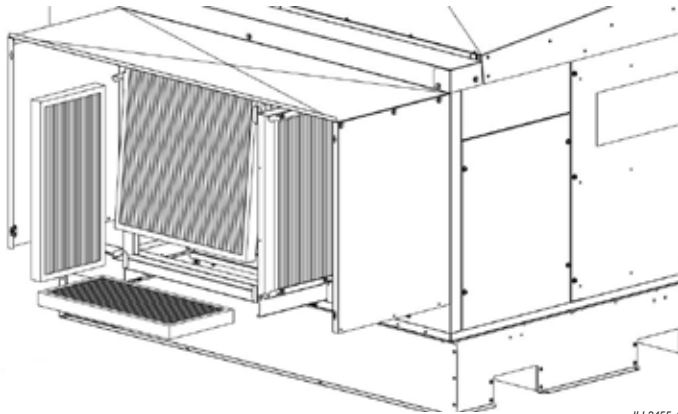

CHANGING COOLER CORES

SIDE VIEWS

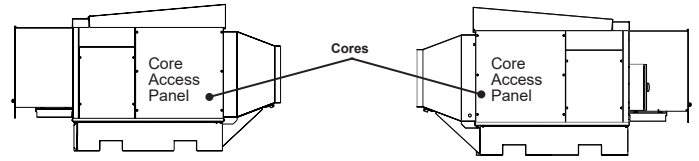

TOP VIEW

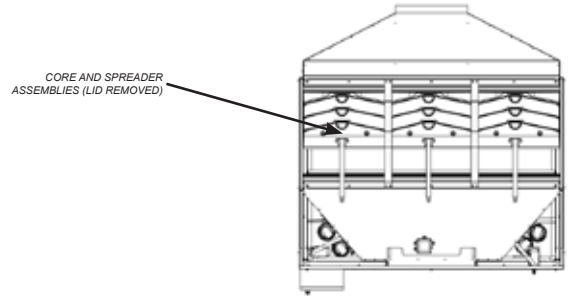

ILL2450-A

1. Power OFF, water OFF.
2. Disconnect and remove any fixed ducting from the exhaust outlet of the cooler (if fitted).
3. Remove the exhaust transition/lid assembly from the cooler.

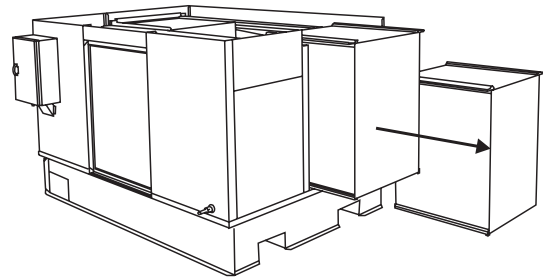

ILL2462-A

4. Open the core access panels on either side of the cooler.
5. Remove the metal core clamp strips
6. Disconnect the spreader assembly from the rubber core extrusions and remove the water spreader assemblies. They can be placed aside onto the lid of the cooler cabinet while still remaining connected to the plumbing system.

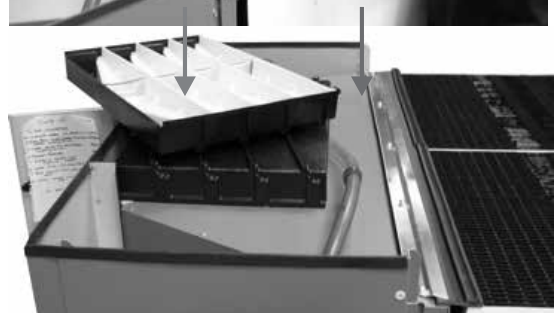

ILL2456-A

MAINTENANCE INSTRUCTIONS cont.

CHANGING COOLER CORES

7. The cores can now be slid out from either side of the cooler through the access panel openings. Take care to ensure the cores are not damaged during removal. They can be heavy and fragile when wet. (If wet, run the cooler on vent for a period of time before removing.) Grasp the cores around the top section to ensure no delamination of the core occurs while moving them.



ILL2457-A

8. To re-assemble, position the cores into the cooler starting at the centre. For all cores the front of the core must face the cooled air outlet of the cooler as below.

CHANGING COOLER CORES - ORIENTATION

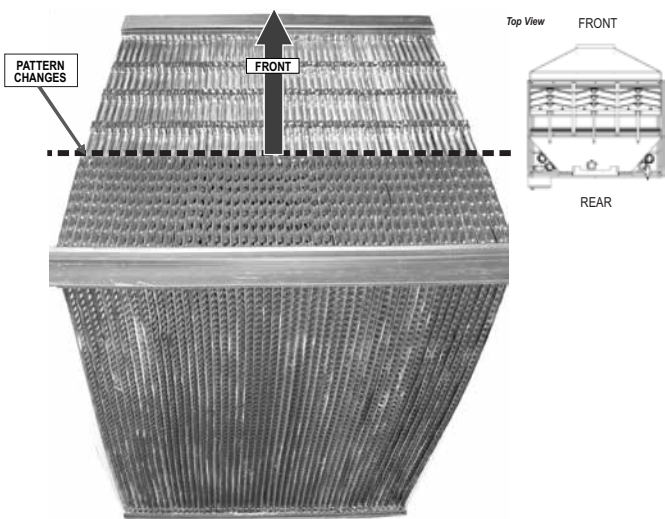
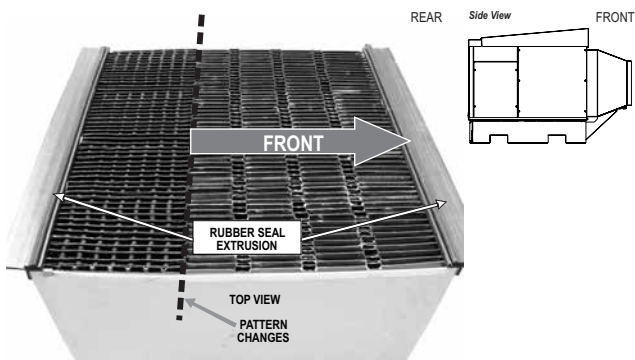

ILL2458-A

9. Locate the water spreader assembly front flange into the extrusion at top front of the cores.

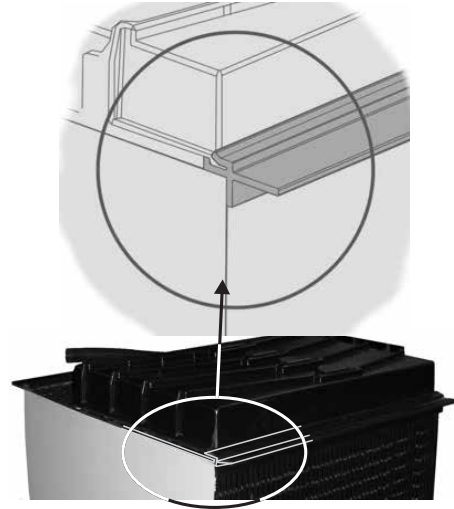

ILL2459-A

10. Check the cores fit snugly and squarely across the width of the core platform and are firmly butted together. Check for a uniform gap at either side of the cooler between the side walls and the core. The core access door has a seal to take up any resultant gap.

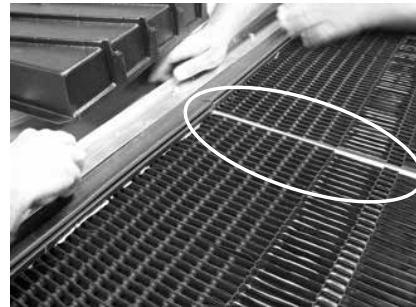

ILL2460-A

11. Refit the core clamp strips clamping over the extrusion located at the top of the cores.



ILL2461-A

12. Ensure a good seal between the cores and the access door when closing. When re-securing the access doors, start from the bottom screws and work up.
13. Refit the exhaust transition/lid assembly to the cooler.
14. Refit any fixed ducting to the exhaust outlet of the cooler.
15. Turn water and power back on to the cooler.

MAINTENANCE INSTRUCTIONS cont.

CHANGING COOLER CHILLCEL PADS (CW-H15S, H15S Plus ONLY)

1. Remove the cooler cores as per the “Changing Cooler Cores” section. The additional chillcel is located on the supply outlet side of the cooler cores.
2. Remove the chillcel retention rail at the top of the chillcel.

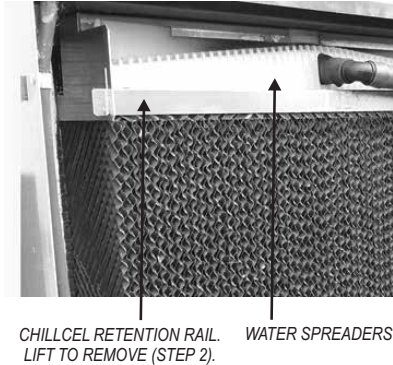

3. Raise the water spreaders and tilt the chillcel forwards from the top. Continue to tilt the chillcel until it clears the spreader. The pad on the far right may require to be slid centre-bound before removing to better clear the water hosing. It is recommended to remove the pad on the far left first.

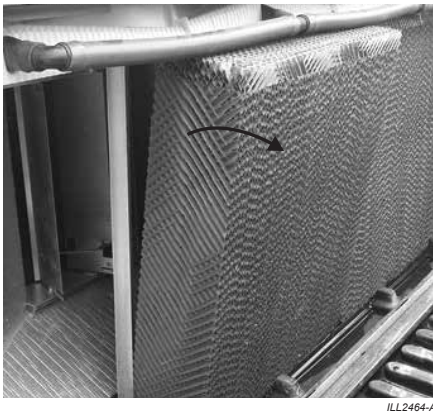

4. To re-assemble, first position the top of the far right pad underneath the spreader and push the base of the pad into place before sliding the pad into its final position.
5. Note the chillcel pad has a small header block; this is the top of the chillcel pad and must be positioned under the water spreader for the pad to function correctly.
6. Reposition the extruded T-section at the rear of the pad, wedging it between the spreader rail and the drip tray.
7. Refit the centre and far left pad.
8. Refit the chillcel retention rail.
9. Re-assemble the cooler cores.

MAINTENANCE INSTRUCTIONS cont.

OPERATING AND FAULT CODE DIAGNOSIS

There are 2 methods for confirming the cooler operation and diagnosing faults on the cooler.

A: LED:

There are two LED indicators on the main printed control board assembly (located in the control box) - refer below.

- Tri-Colour LED (upper LED) is used as an operational and fault indicator. **NOTE:** Tri-colour LED double flashing Green (every 2 seconds) = Normal Operation
- Red LED (lower LED) is used to indicate the condition of water salinity and configuration of the water management system.

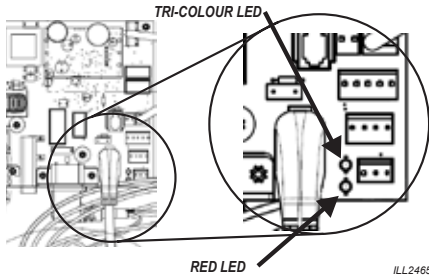

TRI-COLOUR LED: This LED indicates the status of the cooler and indicates Fault Codes (if applicable)

TRI-COLOUR LED	CODE	FAULT - SEE USER MANUAL FOR FULL DESCRIPTION
2 Green Flash	-	NORMAL OPERATION
1 Red Flash	FC #1	WALL CONTROL COMMUNICATION FAILURE
2 Red Flash	FC #2	NO WATER AT LOW PROBE 20 MINS AFTER INLET OPEN
3 Red Flash	FC #3	NO WATER AT HIGH PROBE 20 MINS AFTER LOW PROBE
4 Red Flash	FC #4	WATER SENSED AT LOW PROBE 20 MINS AFTER DRAIN
5 Red Flash	FC #5	WATER SENSED AT HIGH PROBE BUT NOT LOW PROBE
6 Red Flash	FC #6	WATER STILL SENSED AT HIGH PROBE AFTER 4 HOURS
7 Red Flash	FC #7	MOTOR ERROR
-	FC #8	WARM START. PCBA HAS NOT RESET
11 Red Flash	FC #b	SMART CARD MISSING OR CORRUPTED
1 Green/Red	-	CHLORINATOR DEGRADED, REPLACE NEXT SERVICE
2 Green/Red	-	CHLORINATOR SERIOUSLY DEGRADED, REPLACE NOW
3 Green/Red	FC #A	CHLORINATOR REACHED END OF LIFE, REPLACE NOW
4 Green/Red	-	CHLORINATOR SHORT CIRCUIT WARNING
5 Green/Red	FC #A	CHLORINATOR SHORT CIRCUIT FAULT

860912-A TRI COLOUR

RED COLOURED LED: This LED indicates the status of the conductivity measurement circuit and the status of the Salinity Control Method

RED LED	SALINITY CONTROL METHOD.
On Solid	NO WATER AT LOW PROBE OR CONDUCTIVITY <9µS/cm
1 Flash	WATER MANAGER AND CONDUCTIVITY < 1500µS/cm.
2 Flash	WATER MANAGER AND CONDUCTIVITY < MAX (Parameter A5)
3 Flash	COUNT 8 RE-FILLS TO HIGH PROBE (Parameter A1)
4 Flash	24 HOUR CLEAN DRAIN MODE RUNNING

860912-A RED

B:WALL CONTROL DISPLAY

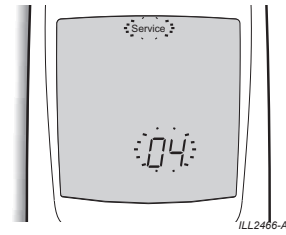

If controlled by a Climate Wizard Wall Control, the wall control can be used to enter the fault code history log, which details the last four (4) faults in the system and the last four (4) types of faults that have occurred.

The fault code history log may be entered at any time after the cooler power has been turned ON. The fault code history log is entered via the wall control using the following method:

1. Whilst the wall control is in "OFF" state, push and hold **AUTO** and **←** buttons simultaneously for at least one (1) second.
2. After one (1) second "F1" and the word "Param" will be displayed.
3. Pressing **AUTO** button will change "F1" to the current or last fault code number e.g., "01" and the word "Param" will change to the word "Value" this indicates the fault code number that occurred.
4. Press **AUTO** button to return to the original "F1" and "Param" display.
5. Use buttons **←** or **→** to scroll through the fault log.
6. Fault indicators - "F1 to F4" - are the last four faults that were recorded by the CPMD, and they might get repeated if the fault has re-occurred. Fault indicators - "FA to Fd" - are the last four types of faults that have occurred in this CPMD, and they will only repeat if a different type of fault has occurred since the last time this type of fault occurred.
7. If no buttons are pushed after sixty (60) seconds the wall control will reset to the "OFF" state. The procedure to enter the fault code history log must then be re-initiated.
8. Clear fault code once you have diagnosed the fault. Whilst in fault code mode press and hold the **COOL** button for five (5) seconds.

See the following page for Fault Code Explanations and Troubleshooting Guide.

MAINTENANCE INSTRUCTIONS cont.

All faults below shut the cooler down unless stated.

LED	Wall Control Fault Code	Fault Description	Suggested Remedy
2 Green Flash then 2 seconds off	-	NORMAL OPERATION	-
1 Red Flash then 2 seconds off	Fault Code #1	COMMUNICATION FAILURE Wall Control: No valid message for 10 seconds	Check communication cable connections. Replace Wall Control. Replace Communication Cable.
2 Red Flash then 2 seconds off	Fault Code #2	FAILURE TO DETECT WATER AT LOW PROBE No water at low probe 20 minutes after solenoid valve opening.	Check water supply on. Check solenoid valve open. Check drain valve closed. Check water management probe position relative to drain valve overflow. Clean water management probe.
3 Red Flash then 2 seconds off	Fault Code #3	FAILURE TO DETECT WATER AT HIGH PROBE No water at high probe 20 minutes after water detected at low probe.	Check solenoid valve open. Check water management probe position relative to drain valve overflow. Clean water management probe. Check water supply pressure sufficient to maintain tank capacity.
4 Red Flash then 2 seconds off	Fault Code #4	FAILURE TO CLEAR LOW PROBE DURING DRAIN Water still detected at low probe 20 minutes after drain opened.	Check drain valve open. Check drain pipework not blocked. Check solenoid valve closed. Clean water management probe.
5 Red Flash then 2 seconds off	Fault Code #5	WATER DETECTED AT HIGH PROBE BUT NOT LOW PROBE.	Clean water management probe.
6 Red Flash then 2 seconds off	Fault Code #6	FAILURE TO CLEAR HIGH PROBE. Water still detected at high probe after 4 hours running in Cool mode.	Check solenoid valve not stuck open. Check all pumps operating when required (1 minute every 9 minutes). Clean pumps. Check pump hoses not blocked. Check excessive rain not entering cooler. Clean water management probe.
7 Red Flash then 2 seconds off	Fault Code #7	MOTOR ERROR.	Check Motor Power Cable connections. Check Motor Communications Cable connections (including) built in resistor.
-	Fault Code #8	WARM START Mains input voltage is under 90Vac but not low enough to reset the PCB. Fault Code recorded when voltage returns to useable level.	Consult with Building Manager.
11 Red Flash then 2 seconds off	Fault Code #B	SMART CARD ERROR The Smart Card is missing or corrupted. Cooler performance is restricted to minimum Fan Speed.	Remove and lightly clean smartcard. Replace smartcard. Replace PCBA.
1 Green/Red Flash then 2 seconds off		CHLORINATOR PERFORMANCE DEGRADED Chlorinator operating current is less than set point.	Clean Chlorinator Check flushing hose correctly attached. Prepare to replace Chlorinator at next service.
2 Green/Red Flash then 2 seconds off		CHLORINATOR PERFORMANCE SERIOUSLY DEGRADED Chlorinator operating current is less than 50% of set point.	Replace Chlorinator now to avoid fault in near future.
3 Green/Red Flash then 2 seconds off	Fault Code #A	CHLORINATOR REACHED END OF LIFE	Replace Chlorinator now.
4 Green/Red Flash then 2 seconds off		CHLORINATOR SHORT CIRCUIT WARNING Chlorinator current >> target.	Clean Chlorinator Check flushing hose correctly attached. Check no debris between the Chlorinator Plates.
5 Green/Red Flash then 2 seconds off	Fault Code #A	CHLORINATOR SHORT CIRCUIT FAULT Chlorinator current >> target again within 15 mins of reservoir drain and re-fill.	Check no debris between the Chlorinator Plates. Replace Chlorinator now.

MAINTENANCE INSTRUCTIONS cont.

Other potential problems

Problem	Probable Cause	Suggested Remedy
Inadequate Cooling	Cooler running in VENT mode	Turn to COOL mode.
	Cooler running in COOL & AUTO mode with incorrect set point.	Adjust Wall Control Set Point Move Wall Control to more appropriate location.
	Under-Sized Cooler	Discuss with Building Manager
	Under-Sized Ducts	
	Clogged or Dirty Cores or Chillcel	Clean or Replace
	Dirty Inlet Air Filter	
	Discharge Damper Incorrect Set	Complete setting the Supply Air Discharge Damper on "Setting the Air Discharge Damper" on page 26
	No or Low Water supply to Cores.	Clean pumps Check pump hoses not blocked.
Chillcel Relay not powered (CW-H15S, H15S Plus only)	Check power supply to pump relay (see "Climate Wizard Supercool Installation" on page 21). Adjust BMS program.	
Excessive Humidity	Inadequate building exhaust	Open windows and doors
	Reduce Supercool/Chillcel usage (CW-H15S, H15S Plus only)	Discuss with Building Manager Adjust BMS program.
Noisy Cooler	Fan out of balance	Clean fan blades
	Under-Sized Ducts/Grilles	Discuss with Building Manager
Cooler Fails to Start/Not Running	Cooler Fault	Check Fault Code Log on Wall Control Check Tri-Colour LED on the main PCBA
	No Power to Cooler	Check Circuit Breaker Consult with Building Manager.
	Low Voltage to Cooler	
	Wall Control in AUTO or AUTO TIMER MODE	Adjust set point and/or timer settings Switch to MANUAL mode to check fan operation.
Continuous overflow of water.	Water Management System not functioning.	Check drain valve opens during manual drain. Check drain pipework not blocked. Check solenoid valve not stuck open. Clean water management probe.
Unpleasant odour.	New cooler core.	Drain reservoir, refill.
	Cooler located near source of unpleasant odour.	Remove source of odour or relocate cooler.
	Algae in reservoir water.	Drain reservoir, clean thoroughly with strong cleansing agent, refill.
	Cores remain wet after shut down.	Run fan on "vent" for 3 hours after cooling cycle to dry cores out.
	Heavy core deposits.	Replace cores.
Pump running Dry	Only 1 pump running/1 pump running dry (CW-H15S and CW-H15S Plus only)	CW-H15S coolers come with an additional pump to wet the direct evaporative cooling media. This pump is controlled via a separate 24VDC relay inside the cooler's control box and will run independently of the other 3 pumps. Depending upon the BMS and/or initial setup this may include periods when there is no water in the tank. There is no problem with the pump running dry. Suggested Remedy: None required.
Excessive water carryover in exhaust airstream	Plenum pressures too high, 2. Core seals/spreaders moved during transport.	Complete the "Setting the Supply Air Discharge Damper" procedure on "Setting the Air Discharge Damper" on page 26. Check spreader assemblies securely clamped to top of cores and gaps between cores covered up. Check core doors correctly sealing against sides of cores.

MAINTENANCE SCHEDULE

Installation Date: / /	Installer:
--------------------------------------------------	-------------------

It is a condition of your warranty cover that the items in the schedule below are checked (and action taken as required) once every 3 months from the date of installation by a qualified, licensed technician, and that the schedule is properly filled out (i.e. name, signature, date, action taken). Note that Air inlet filters must be inspected and cleaned every month, not just every 3 months. Even after the warranty period expires, please continue to have the product maintained as per the items and the frequency in the schedule, using the additional Maintenance Schedule pages provided. This will help to prolong the life of the cooler and keep it running efficiently.

ATTENTION! if your cooler is used for personal residential household purposes, then these additional pages will need to be used for recording the services required during the warranty period.

Service Item	Check/Adjust				Clean				Replace			
	Q1	Q2	Q3	Q4	Q1	Q2	Q3	Q4	Q1	Q2	Q3	Q4
Electrical Connections and Component Operation												
Electrical wiring												
Fan motor												
PCBs & Control box												
Drain valve												
Water inlet solenoid												
Water probes												
Chlorinator												
Water pump												
Water Distribution System												
Water distribution system - hoses and spreaders												
Water level												
Cabinet and Accessories												
Cabinet integrity / leaks												
Air inlet												
Air inlet filters - 1st month of quarter												
Air inlet filters - 2nd month of quarter												
Air inlet filters - 3rd month of quarter												
Tank												
Fan												
Impeller - inlet cone alignment												
General Operation												
Start up and run sequence												
Control operation												
Air outlet vane setting (indicate setting in Pa)												
General Installation												
Electrical connections												
Water connections												
Duct condition												
Roof penetrations												
Mounting & Vibration isolation												
Access												

Service No.	Service Date	Service Technician	Service Company
No.1
No.2
No.3
No.4
No.5
No.6
No.7
No.8

MAINTENANCE SCHEDULE cont.

Service Item	Check/Adjust				Clean				Replace			
	Q5	Q6	Q7	Q8	Q5	Q6	Q7	Q8	Q5	Q6	Q7	Q8
Electrical Connections and Component Operation												
Electrical wiring												
Fan motor												
PCBs & Control box												
Drain valve												
Water inlet solenoid												
Water probes												
Chlorinator												
Water pump												
Water Distribution System												
Water distribution system - hoses and spreaders												
Water level												
Cabinet and Accessories												
Cabinet integrity / leaks												
Air inlet												
Air inlet filters - 1st month of quarter												
Air inlet filters - 2nd month of quarter												
Air inlet filters - 3rd month of quarter												
Tank												
Fan												
Impeller - inlet cone alignment												
General Operation												
Start up and run sequence												
Control operation												
Air outlet vane setting (indicate setting in Pa)												
General Installation												
Electrical connections												
Water connections												
Duct condition												
Roof penetrations												
Mounting & Vibration isolation												
Access												

Service No.	Service Date	Service Technician	Service Company
No.1
No.2
No.3
No.4
No.5
No.6
No.7
No.8

MAINTENANCE SCHEDULE cont.

Service Item	Check/Adjust				Clean				Replace			
	Q9	Q10	Q11	Q12	Q9	Q10	Q11	Q12	Q9	Q10	Q11	Q12
Electrical Connections and Component Operation												
Electrical wiring												
Fan motor												
PCBs & Control box												
Drain valve												
Water inlet solenoid												
Water probes												
Chlorinator												
Water pump												
Water Distribution System												
Water distribution system - hoses and spreaders												
Water level												
Cabinet and Accessories												
Cabinet integrity / leaks												
Air inlet												
Air inlet filters - 1st month of quarter												
Air inlet filters - 2nd month of quarter												
Air inlet filters - 3rd month of quarter												
Tank												
Fan												
Impeller - inlet cone alignment												
General Operation												
Start up and run sequence												
Control operation												
Air outlet vane setting (indicate setting in Pa)												
General Installation												
Electrical connections												
Water connections												
Duct condition												
Roof penetrations												
Mounting & Vibration isolation												
Access												

Service No.	Service Date	Service Technician	Service Company
No.9
No.10
No.11
No.12

To Owner/User: please note that as explained in your warranty document, installation is not covered by the warranty (for example duct work, roof penetrations, electrical and water connections etc.). However, we still require that you have these items checked because they can affect the performance (and/or safety) of the cooler. This is why they have been included in the maintenance schedule.

SPARE PARTS

SPARE PART COMPONENTS

Item	Seeley Part	Description
1	094526	Drain Valve, 12VDC & Adaptor
2A	095813	Pump, 1.5m (4.92') Lead, 230/50 AUS
2B	117607	Pump, 1.5m (4.92') Lead, 230/60 USA
3	114279RP	Wall Control, Mount Plate & Fasteners
4	094700	PCBA, BMS Interface
5	094861	Core Block CW-H
6A	094885	Solenoid, Water Inlet - BSP AUS
6B	094960	Solenoid, Water Inlet - NPT USA
7	093987	Chlorinator Assy
8	094823	Water Management Probe
9A	116877	Fan/Motor CW-H10 Aus/Eur 380-415V 3~
9B	114729	Fan/Motor CW-H15, H15S, H15S Plus Aus/Eur 380-415V 3~
9C	114743	Fan/Motor CW-H15, H15S, H15S Plus USA 440-480V 3~
9D	114712	Fan/Motor CW-H15, H15S, H15S Plus USA 200-240V 3~
9E	117447	Fan/Motor CW-H15, H15S, H15S Plus USA 200-240V 1~
10A	094755	PCBA, Cooler Control CW-H AUS
10B	094762	PCBA, Cooler Control CW-H USA
11A	094717	Control Cable 20m (65')
11B	094724	Control Cable 40m (131')
12A	120423	Air Filters - CW-H10
12B	120393	Air Filters - CW-H15, H15S, H15S Plus
13A	094373	Smartcard H10 (380-480V/3~)
13B	094335	Smartcard H15 (380-480V/3~)
13C	094366	Smartcard H15 (380-480V/3~) HIGH ALTITUDE
13D	094380	Smartcard H15S Plus (380-480V/3~)
13E	094397	Smartcard H15S (380-480V/3~)
13F	093963	Smartcard H15 (200-240V/3~)
13G	TBC	Smartcard H15 (200-240V/3~) HIGH ALTITUDE
13H	093956	Smartcard H15S Plus (200-240V/3~)
13I	093970	Smartcard H15S (200-240V/3~)
13J	093994	Smartcard H15 (200-277V/1~)
13K	TBC	Smartcard H15 (200-277V/1~) HIGH ALTITUDE
13L	TBC	Smartcard H15S Plus (200-277V/1~)
13M	TBC	Smartcard H15S (200-277V/1~)
14	094830	Spreader Kit 1PK CW-H
15A	094779	Motor Contactor 3~ CW-H
15B	865065RP	Motor Contactor 1~ CW-H
16	094793	RFI Filter Elec Box CW-H
17	094748	Power Supply, 12Vdc, CW-H USA
18	094731	Transformer, 230-460V, CW-H USA
19	115894	Panel Door Screw Kit
20	115917	Panel Door Nutsert Kit
21	115993	Panel Door Kit - Core
22	116082	Panel Door Kit - Pump
23	117669	Screw Retrofit Kit - Pump and Probe
24	117270	24VDC Relay CW-H15S
25	117294	Chillcel 3off 637x545x150 CW-H15S

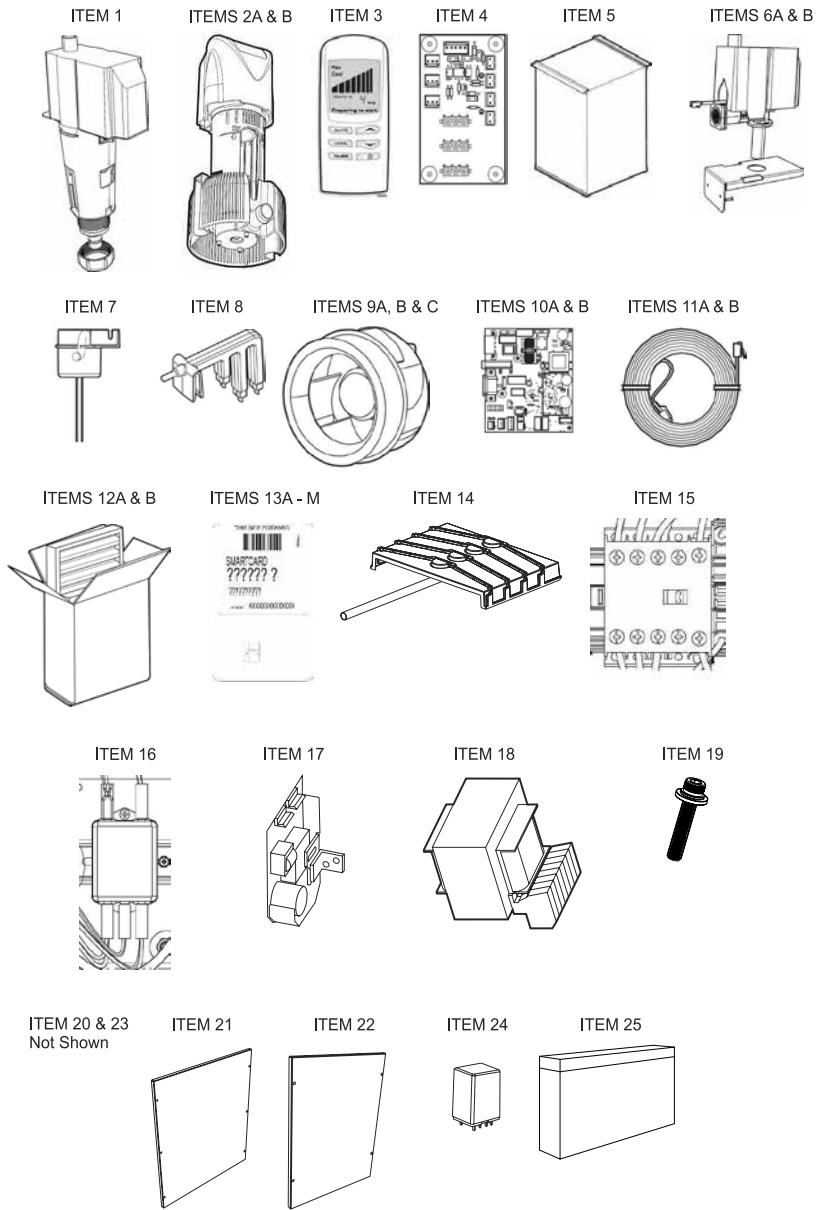

ILL2467-B

HOW TO REGISTER YOUR PRODUCT WARRANTY (AUSTRALIA ONLY)

Warranty Information section

HOW TO REGISTER YOUR PRODUCT WARRANTY (Australia only)

Please register your warranty online by visiting seeleyinternational.com and selecting COMMERCIAL section on the top right hand side of the screen. Then follow these steps:

- Step 1** Select **REGISTER FOR WARRANTY**
- Step 2** Enter your product serial number and "**SUBMIT**"
- Step 3** Enter the required information and "**SUBMIT**"

Alternatively, go to www.seeleyinternational.com/commercial/register-a-product-for-warranty which will take you directly to the product warranty registration page.

Important Note: You need to have the following information to complete your registration:

- your unit model and size
- serial number
- date your system was installed
- name of the dealer/installer you purchased it from

Please complete this section. You will also need to retain your purchase receipt, and proof of any warranty period extension.

Brand: _____
Model: _____
Serial No: _____
Customer Name: _____
Installation Address: _____
Date of Installation: _____
Installer / Dealer: _____

As with any product that has moving parts or is subject to wear and tear, it is **VERY IMPORTANT** that you maintain your Climate Wizard and have it regularly serviced. It is a condition of warranty cover for your Climate Wizard that you comply with all of the maintenance and service requirements set out in the Owner's Manual. Compliance with these requirements will prolong the life of your Climate Wizard. Further, it is also a condition of warranty cover that each item in the Maintenance Schedule in the Owner's Manual is performed with the frequency indicated, by a qualified, licensed technician, and that the Maintenance Schedule is properly filled out (i.e. names, signature, date, and action taken) when the item is completed.

ANY FAILURE TO CARRY OUT THE REQUIRED MAINTENANCE AND SERVICING REQUIREMENTS, AND ANY FAILURE TO PROPERLY FILL OUT THE MAINTENANCE SCHEDULE, WILL VOID YOUR WARRANTY.

WARRANTY TERMS AND INFORMATION (AUSTRALIA ONLY)

Warranty Details (Australia only)

In this warranty:

We or **us** means Seeley International Pty Ltd (Seeley) ABN 23 054 687 035, and our contact details are set out at the end of this warranty;

You means you, the original end-user purchaser of the Goods;

Supplier means the authorised distributor or retailer of the Goods that sold you the Goods in Australia;

Goods means the product, unit, appliance or equipment which was accompanied by this warranty and purchased in Australia; and

Relevant Warranty Period means the various warranty periods as described in clause 1 below, as appropriate.

Our Goods come with guarantees that cannot be excluded under the Australian Consumer Law. You are entitled to a replacement or refund for a major failure and for compensation for any other reasonably foreseeable loss or damage. You are also entitled to have the Goods repaired or replaced if the Goods fail to be of acceptable quality and the failure does not amount to a major failure.

In addition to any rights and remedies that You may have under the Australian Consumer Law or any other law, subject to the terms of this warranty, We provide the following warranty:

1. If during the first one (1) year from the date of purchase, the Goods upon examination prove defective by reason of improper workmanship or material, We will repair or replace at our option, the Goods or any part thereof without charge for either parts or labour during normal working hours.
2. The warranty granted under clause 1 applies to all components which form part of the original air cooler, but does not cover:
 - a. fair or normal wear and tear;
 - b. damage, loss or claims caused by, resulting from, or arising out of any utilities that service or are connected to the Goods. This includes but it is not limited to electrical surges, and inadequacies, failure, or other problems in or with any electricity, power, or water supply to the Goods;
 - c. after the first year: the replacement, supply, or servicing of consumable items (including without limitation washers, seals, and drive belts);
 - d. despite clause 2.c. above, the air filters;
 - e. installation (including without limitation ductwork, fittings, and other related installation components) which is excluded and.
 - f. batteries (including damage caused by leaking or faulty batteries), cracking or breaking of display screens in controllers, physical damage caused by the user or third parties, and accidental breakage.
3. During the period to which any expressed warranty applies, all defective part(s) shall be replaced or repaired (at the discretion of Seeley) without charge for either parts or labour, during normal working hours. Should we deem in our absolute discretion to replace the Goods pursuant to clause 1, we may substitute any similar good even if it is not on our current price/equipment list. Further, Goods presented for repair may be replaced by refurbished goods of the same type rather than being repaired. Refurbished parts may be used to repair the Goods.
4. We are under no obligation to repair or replace the Goods or Parts under clause 1 above if (i) the Goods have not been installed and commissioned in accordance with the Installation Instructions (ii) the Goods have not been installed and commissioned properly or competently, (iii) the Goods have not been operated, serviced and maintained in accordance with the instructions provided in the Owner's Manual, or (iv) any such service or maintenance has not been properly or competently performed. The addition of any third party device or the removal or the alteration of any Seeley component or damage due to the misuse of the unit or faulty installation or commissioning will void this warranty. Further, it is a condition of warranty cover that each item in the Maintenance Schedule in the Owner's Manual (if it was published with such a Schedule) is performed with the frequency indicated, by a qualified, licensed technician, and that the Maintenance Schedule is properly filled out (i.e. names, signature, date, and action taken) when the item is completed. Any failure to carry out the required maintenance and servicing requirements, and any failure to properly fill out a Maintenance Schedule in the Owner's Manual, will void your warranty.
5. As far as the law permits, We will not be liable for any consequential loss suffered through, or resulting from, the non-operation, or ineffective operation of the air cooler. The warranties granted under clause 1 do not cover damage to the air cooler or other loss resulting from acts of God.
6. No other person, company or corporation is authorised to offer, or give on our behalf, any other warranty. The benefits conferred are in favour of You and any person deriving title to the air cooler whilst in its original place of installation. Nothing in this warranty shall be construed as affecting any rights You may have under all the relevant laws, or Commonwealth or State Legislation which give You rights which cannot be modified or excluded by agreement.
7. In order to claim under the warranties granted under clause 1 You must:
 - a. either:
 - contact us within the Relevant Warranty Period on: 1300 650 644; or
 - log a warranty claim on our website (website address below) within the Relevant Warranty Period; and
 - b. make available for inspection by the service agent who will come to the location of the Goods or send to us at the address below within the Relevant Warranty Period: (i) the legible and unmodified original proof of purchase, which clearly indicates the name and address of the original retailer, the date and place of purchase, the product name or other product serial number, (ii) all of your records of all service and maintenance carried out to the Goods, plus the Maintenance Schedule in the Owner's Manual (if it was published with such a Schedule) (iii) a copy of the completed Warranty Information page in this warranty, and (iv) if an extended warranty period was provided by us for the Goods, then the relevant document provided by us confirming that extended warranty period. If you choose to send the documents described in (i) to (iv) to us, then they must be accompanied by a covering letter which states your name and address and daytime telephone number, the address at which the Goods are installed, and the model and serial number of the Goods.

WARRANTY TERMS AND INFORMATION (AUSTRALIA ONLY) cont.

8. The warranty granted in clause 1 covers the costs of parts and labour but you will be responsible for:
 - a. the cost of travel incurred for a Seeley International service agent to get to and from the location of the Goods if the location of the Goods is either: (i) outside the metropolitan areas of the capital cities; or (ii) more than 35 kilometres from an authorised Seeley International branch or service representative; and
 - b. any costs for additional labour or equipment associated with gaining acceptable and safe service access to the Goods installed in restricted, high or unsafe locations, and or the removal and replacement of any barrier, walls, roofs, floors, fences etc.; and
 - c. any costs incurred by the Seeley International service agent in gaining access to the Goods which is necessary to comply with any safety or workplace safety requirements and/or any other relevant regulations. For the avoidance of doubt, the reference to any costs incurred also includes the cost of any necessary site inductions.
9. We are not responsible in any way for any failure and/or inadequate performance of the Goods which arises from or is connected to the use in the Goods of non-genuine spare parts. We strongly recommend that only spare parts supplied or approved by us are used in the Goods.
10. We are not responsible for the installation of the Goods and expressly disclaim all liability resulting from incorrect installations or installations that do not conform to local electrical codes, local plumbing codes, Occupational Health and Safety requirements, and by laws which are legislated or in effect at the time of installation.
11. This warranty is only valid and enforceable in Australia.

Note: It is important that the safety and privacy of our service technicians is protected at all times. Accordingly, We and our Seeley International service agents reserve the right to refuse service if (i) safety and accessibility to the unit cannot be guaranteed or (ii) the owner of the unit, occupant of the site where the Goods are located, or any other third party seeks to take photographs, or make a video or audio recording, of the service technician(s) while they are on the site or carrying out service to the unit. If a service technician attends the site but subsequently leaves for any of these reasons then a service charge will be made for the call which charge shall be a debt immediately due and payable by the person or entity that has made the claim under this Warranty.

If a service call reveals no warranty fault found with the Goods, a charge will be made for the call.

Our liability under this warranty is limited to the extent permitted by law. That is, to the extent that it is fair and reasonable, if the Goods are not of a kind ordinarily acquired for personal, domestic or household use or consumption, your remedies associated with any failure or defect of the Product will be limited to:

- a. the replacement of the Goods or the supply of equivalent goods;
- b. the repair of the Goods;
- c. the payment of the cost of replacing the Goods or of acquiring equivalent goods;
- d. the payment of the cost of having the Goods repaired

and subject to the terms and conditions included in this warranty.

SERVICE DEPARTMENT

Seeley International Pty Ltd

112 O'Sullivan Beach Road

Lonsdale, South Australia 5160

Customer service centre 1300 650 644

Website: www.seeleyinternational.com

FOR SERVICE

Service call Booking

To book a Service on your Seeley International product Online visit www.seeleyinternational.com and selecting COMMERCIAL section on the top right hand side of the screen. Then follow these steps:

Step 1 Select “SUPPORT” and “BOOK A SERVICE”.

Step 2 On the “FIND A SERVICE AGENT” page, enter your POSTCODE and select a category (“COMMERCIAL - CLIMATE WIZARD”), select the “SEARCH” button.

Step 3 On the “RESULTS” page, select the “BRAND” of your cooler.

Step 4 Choose “SELECT” for your preferred agent from the list provided.

Step 5 Select “BOOK A SERVICE” and complete the required steps and fields.

or Phone 1300 650 644 to be directed to your closest authorised Service Agent.

PRIVACY NOTICE

Seeley International Pty Ltd ABN 23 054 687 035 will use the personal information you provide us with to provide warranty support for the product you have purchased and to inform you about other products and services. If you choose not to supply us with the information requested, we may be unable to provide you with warranty support. We may also disclose your information to third parties, such as related entities; retailers, distributors, service agents and contractors who are affiliated with us; or marketing or market research companies. If you would prefer not to receive direct marketing communications from us, please follow the instructions to “unsubscribe” which will be included in the direct marketing communications we send you, or contact our Privacy Officer using the details set out below. While we do not currently transfer personal information to overseas recipients or store personal information overseas, if we transfer your information to third parties who do so, we will take reasonable steps to ensure that the overseas recipients do not breach the *Australian Privacy Principles*. By registering your warranty, you consent to having your personal information used in this way. Please read our Privacy Policy on our website www.seeleyinternational.com for further explanation of how we collect, use, hold and disclose personal information, and how you may access and seek correction of your information. It also sets out how you may complain about a breach of the Australian Privacy Principles, and how we will deal with your complaint. You may contact us at: Privacy Officer, Seeley International Pty Ltd, 112 O'Sullivan Beach Road, Lonsdale, South Australia 5160.

NOTES

(This Page Left intentionally BLANK)

CW-H
Cooler Installation Manuals

Now provided on the internet
Refer www.seeleyinternational.com

French

Manuel d'Installation de
rafraîchisseur de CW-H
maintenant fourni sur
l'Internet.

Italian

Manuale dell'Installazione
del dispositivo di
condizionatore del CW-H
ora fornito sul Internet.

Spanish

Manual de la Instalación del
climatizador del CW-H ahora
proporcionado en el Internet.

Affix serial & model
number sticker here

Warranty (Australia only)

To register your warranty, go to
www.seeleyinternational.com/commercial/register-a-product-for-warranty



Service

For Australia contact 1-300-650-644
For outside Australia contact your local dealer
seeleyinternational.com

HEAD OFFICE:

Seeley International Pty Ltd, 112 O'Sullivan Beach Road, Lonsdale, SA 5160, Australia

MANUFACTURED BY:

*Seeley International Pty Ltd, 77 North Street, Albury, New South Wales 2640, Australia
(for Australia, Europe and South Africa)*

*Seeley Acquisition Co., Ltd. doing business as Coolerado, 4430 Glencoe Street,
Denver, Colorado 80216, USA (for the USA and the Americas)*

IMPORTED BY:

*Seeley International (Europe) Limited, Unit 11 Byron Business Centre, Duke Street,
Hucknall, Nottingham, NG15 7HP, United Kingdom*

*Seeley International Africa (Pty) Ltd, 6 Witton Road,
Foundersview South, Modderfontein 1609, Gauteng, South Africa*

*It is the policy of Seeley International to introduce continuous product improvement.
Accordingly, specifications are subject to change without notice.
Please consult with your dealer to confirm the specifications of the model selected.*

