

## The Breezair Supercool™ TBQ 500

Reliability and quality  
now available with Black Opal™ MINI-CELL^ Chillcel™ Pads  
and Wi-Fi Smart App

### Permatuf™ corrosion-proof cabinet

The Breezair cabinet will not corrode or rust. The UV stabilised structural polymer material is the same type used to make acid baths, battery cases and some space satellite components.

### Axial fan

This super powerful fan is designed to maximise performance and minimise noise. The purpose designed fans are inherently balanced, with aerofoil blades to provide energy efficient, high pressure performance.



### MagIQcool™ Controller (standard)

Operate one cooler from an easy to use, wall mounted thermostat controller. The controller comes with 20 m wiring loom, that can be extended up to a maximum length of 100 m.

### MagIQtouch™ BMS Control interface (optional)

BMS interface as optional with analogue and digital inputs.



### Advanced touch screen MagIQtouch™ Controller (optional)

The technology includes in-built Installation Wizard, making the operating process simple. Coolers are supplied with a standard 20m cable (40m cable can be supplied as optional) to operate up to 60 coolers from a single MagIQtouch controller.

### NEW!!

### Black Opal™ MINI-CELL^ Chillcel™ Pads

Our revolutionary Black Opa Mini-Cell Chillcel pads have transformed the aesthetics of our coolers as they seamlessly blend into their surroundings; maintaining our global leading Mini-cell Chillcel pad technology, which increases surface area of the pads by 25%, dramatically multiplying cooling capacity and efficiency - BEYOND BELIEF!



^Patent pending



### Totally enclosed motor

Breezair's fan motor is fully enclosed to international standards and excludes any moisture ingress from all sources. The advanced design is rigorously tested and completely reliable.

### Non-clogging water distribution system

Breezair's non-clogging water distribution is one of the things that make it unique. The water distributor maximises cooling efficiency by supplying a continuous and balanced flow of water across the cooling pads. This is different to any other brand of evaporative coolers, which are subject to water flow variations for a number of reasons. Breezair's balanced flow ensures highest evaporation efficiency and maximum cooling.

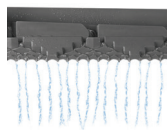

### Tornado® water pump

Designed, manufactured and tested by Seeley International, the Tornado pump epitomises reliability.

### NEW!!

### MagIQtouch™ Wi-Fi Smart App (optional)

Now you can control your Breezair evaporative cooler remotely using your smart devices.



Syncing with the MagIQtouch wall controller you can:

- View the live status of your unit
- Turn the system on/off or in free-cooling mode
- Adjust temperatures and fan speeds
- Override the Program Modes

# Technical specifications

## TBQ 500

Airflow @ 80Pa	Industry standard (m³/h)	9760
Cooling capacity*	(kW)	13.3
Power consumption (total)	Watts max/min	1260 / 400
	Current max (amp)	5.7
Power supply	Voltage / Phases / Hz	220-240 / 1 / 50
Controller	Type	Digital
Fan	Type	Axial
	Dia (mm)	541
Motor	Type	PSC
	Speed max (rpm)	1350
	Output Watts max	750
	Overload & Fuse	Auto reset & 'one-shot' fuse
	Enclosure	IP54
Pump	Type	Centrifugal
	Motor	Synchronous
	Rating Watts (input)	25
	Flow rate (L/min)	21
	Voltage / Phases / Hz	230 / 1 / 50
	Overload	Auto reset
	Enclosure rating	IPX4
Cooling pad ChillCel™	Size (mm)	850 x 526 (H) x 90 (4 pads)
	Pad area (m²)	1.79
Water	Tank capacity (L)	23
	Inlet (mm / inches)	12.7 / ½" male BSP
	Drain (mm / inches)	40 / 1½" male BSP
Shipping	Dimensions including pallet (mm)	1150 x 1150 x 902 (H)
	Volume (m³)	1.19
	Mass (kg)	68
	Operating (kg)	89
Connecting duct (raw edged)	Length x width (mm)	550 x 550

\*Cooling capacity measured to Australian Standard AS2913-2000, ambient of 38°C dry bulb and 21°C wet bulb, with room exit temperature of 27.4°C.

### COOLER DISCHARGE AIR TEMPERATURE CHART

Ambient Dry Bulb Temperature °C	Ambient Relative Humidity %								
	10	20	30	40	50	60	70	80	90
10	2.7	3.6	4.5	5.4	6.2	7.0	7.8	8.5	9.3
15	6.2	7.3	8.4	9.4	10.5	11.4	12.4	13.3	14.2
20	9.5	10.9	12.2	13.5	14.7	15.9	17.0	18.1	19.0
25	12.6	14.4	16.0	17.5	19.0	20.3	21.6	22.8	23.9
30	15.8	17.9	19.8	21.6	23.2	24.7	26.2	27.5	28.8
35	18.8	21.3	23.6	25.6	27.5	29.2	30.8	32.3	33.7
40	21.9	24.8	27.4	29.7	31.8	33.7	35.5	37.1	38.6
45	24.8	28.2	31.2	33.8	36.1	38.2	40.1	41.9	43.5
50	27.8	31.7	35.0	37.9	40.5	42.7	44.8	46.7	48.4

This chart represents approximate air temperatures based on cooling performance at sea level. From tests carried out to Australian Standard 2913.



[www.seeleyinternational.com](http://www.seeleyinternational.com)

**25 Years**  
Corrosion-free cabinets guarantee

**10 Years**  
Structural components guarantee

**2 Years**  
Pump, motor & electronic control module guarantee

### CABINET DETAILS

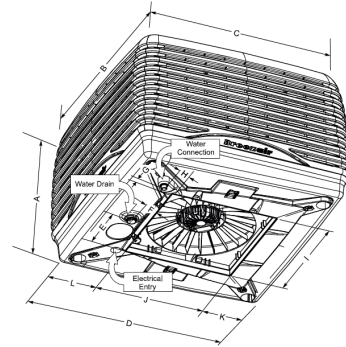

Model#	A	B	C	D	E	F	G	H	I*	J*	K	L
TBQ 500	835	1150	1150	1080	275	95	82	82	555	555	249	279

Note: All dimensions are in mm. \*Dropper dimensions

### FAN CURVE

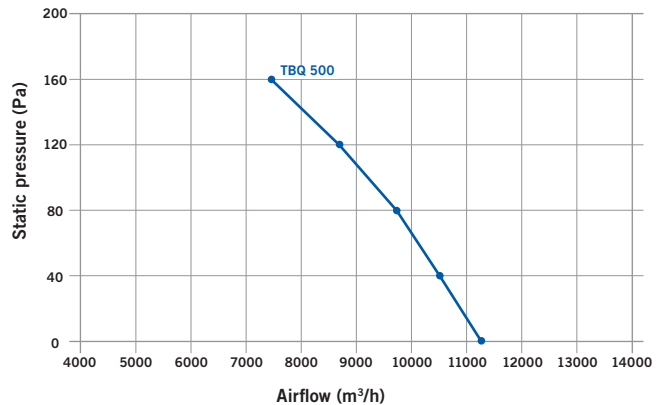

Model#	Industry STD Rating m³/h @ 80Pa	Motor W	Certified Air Delivery (m³/h) (static pressure Pa)				
			0	40	80	120	160
TBS 580	9760	750	11160	10550	9760	8680	7420

[eurosales@seeleyinternational.com](mailto:eurosales@seeleyinternational.com)  
[uksales@seeleyinternational.com](mailto:uksales@seeleyinternational.com)



**Seeley International France**  
320 Avenue Berthelot  
69371 Lyon Cedex 08  
France  
Phone: +33 (0) 472 7847 80

**Seeley International Italy**  
Loc. Policiano 72/M  
52100 Arezzo Italy  
Phone: +39 (0) 575 97189

**Seeley International UK**  
Unit 11 Byron Business Centre,  
Duke Street  
Hucknall Nottingham  
NG15 7HP United Kingdom  
Phone: +44 (0) 115 9635630

