



INSTALLATION & OPERATION MANUAL

MULTI-MAGIC WALL CONTROLLER



TABLE OF CONTENTS

OVERVIEW	2
COOLER MODELS	2
KIT CONTENTS	2
SPECIFICATIONS	2
QUICK START	3
24 V AC/DC POWER AND RS 485 MODBUS COMMUNICATIONS WIRING	3
MAIN SCREEN LAYOUT	4
RS 485 MODBUS NETWORK SETUP - FIRST TIME USE	4
PHYSICAL DESCRIPTION & MOUNTING	5
WALL CONTROLLER INSTALLATION INSTRUCTIONS	6
CONNECTING	7
COMMUNICATION CABLE SPECIFICATION	7
WIRING REQUIREMENTS	7
POWER	8
TERMINATING RESISTOR	9
OPERATION SCREENS	10
MAIN MENU	10
COOL MODE (MANUAL SPEED CONTROL)	11
COOL MODE (AUTOMATIC SPEED CONTROL)	12
VENT MODE	13
PROGRAM MODE	14
EDIT THE 7-DAY PROGRAM	15
SETTING SCREENS	16
MENU	16
TIME AND DATE	17
LANGUAGE	17
SECURITY LOCK	18
TEMPERATURE UNITS	18
CONFIGURATION SCREENS	19
MENU	19
AUTO-RESTART	19
MANUAL DRAIN	19
ROOM SENSORS	19
AMBIENT SENSORS	19
MINIMUM - MAXIMUM FAN SPEED LIMITS	20
MODBUS RS 485 NETWORK SETUP	21
DEVICE MONITOR SCREENS	22
MENU	22
COOLER MONITOR	23
FAULT HISTORY	23
COOLER FAULTS AND TROUBLESHOOTING	25
FAULT SCREEN DISPLAY	25
FAULT CODE DESCRIPTIONS	26
OTHER POTENTIAL PROBLEMS	27
APPENDIX - EXAMPLE WIRING SCHEMATIC	28

OVERVIEW

COOLER MODELS

The Wall Controller is compatible with CW-H and CW-80 coolers with Multi-Magic controls

These instructions are to be read in conjunction with the Installation and Operation and Maintenance literature supplied with the coolers.

KIT CONTENTS

ITEM	IMAGE	ITEM	IMAGE
Multi-Magic Wall Controller		Isolating Screw	
MODBUS 120Ω Terminating Resistor		Instructions	

SPECIFICATIONS

General	
Power supply	24 V AC/DC +/-10 %
Power consumption	3.2 VA 1.3 W max
Degree of protection	IP20
Mounting	Vertical Wall, Surface Mount
Ambient operating temperature	0 to 50 °C (32 to 122 °F)
Ambient operating humidity (non-condensing)	0 to 75%
Ambient storage temperature	-30 to 50 °C (-22 to 122 °F)
Ambient storage humidity (non-condensing)	0 to 75%
Real Time Clock (RTC) data retention	5 years
Embedded Temperature Sensor Characteristics	
Type	10 k NTC type 2 thermistor
Resolution	+/- 0.1 °C (+/- 0.2 °F)
Measurement range	-40 to +50 °C (-40 to +122 °F)
Accuracy	+/- 0.5 °C (+/- 0.9 °F) at 21 °C (70 °F) typical calibration
Embedded Humidity Sensors Characteristics	
Type and calibration	Single point calibrated bulk polymer
Precision	Reading range from 10 to 90% R.H. non-condensing 10 to 20 % precision: 10% 20 to 80 % precision: 5% 80 to 90 % precision: 10%
Stability	Less than 1.0% yearly (typical drift)
Communication	
Type	RS 485 Modbus Client
Maximum of number of Modbus Server devices	15

QUICK START

24 V AC/DC POWER AND RS 485 MODBUS COMMUNICATIONS WIRING

WALL CONTROLLER

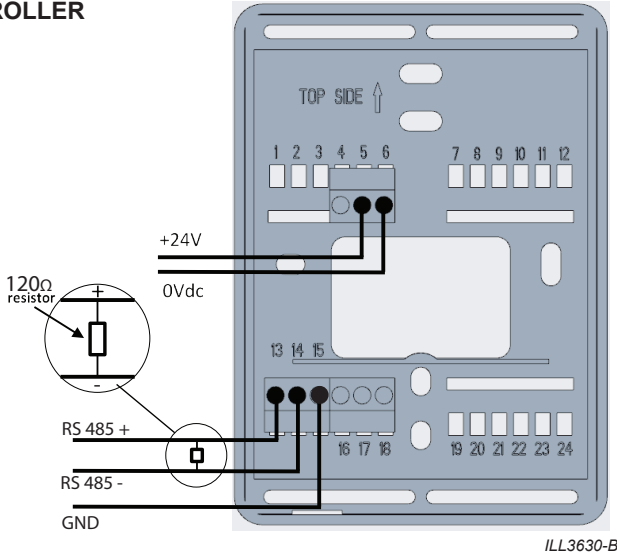

CW-H COOLER

CW-80 COOLER

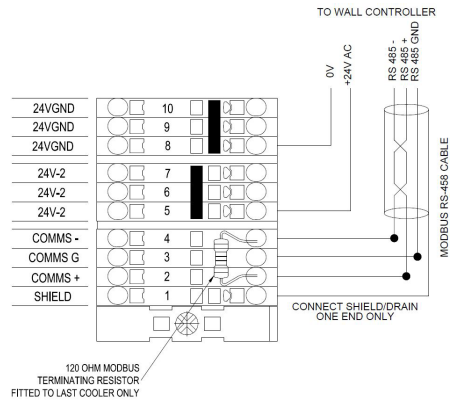
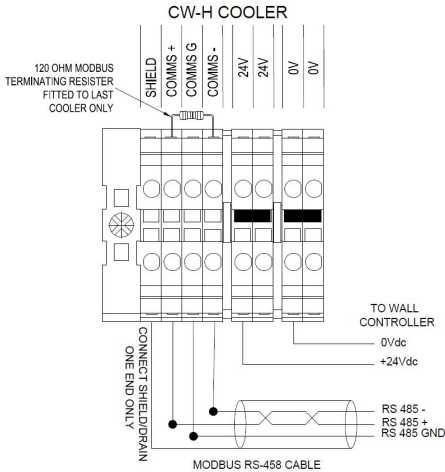

QUICK START

MAIN SCREEN LAYOUT

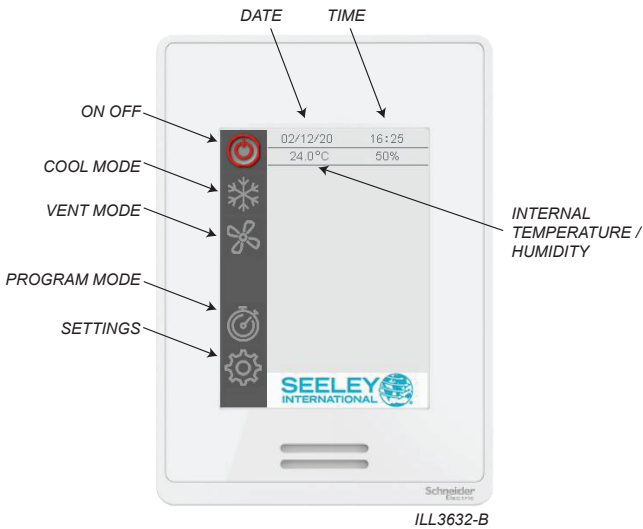

RS 485 MODBUS NETWORK SETUP - FIRST TIME USE

IMPORTANT - The Multi-Magic Wall Controller can control up to 15 CW-H and/or CW-80 coolers. Ensure each cooler is powered up and has a unique node address set. Refer to installation literature provided with the cooler for setup instructions.

Enter SETTINGS – CONFIGURATION – NETWORK menu

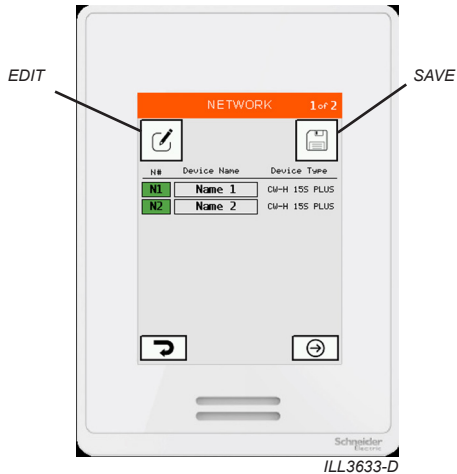

List shows all detected coolers.

Press EDIT to scan network and detect coolers.

Press SAVE to commit detected coolers to Wall Controller memory.

PHYSICAL DESCRIPTION & MOUNTING

WALL CONTROLLER DIMENSIONS AND SETUP NOTES

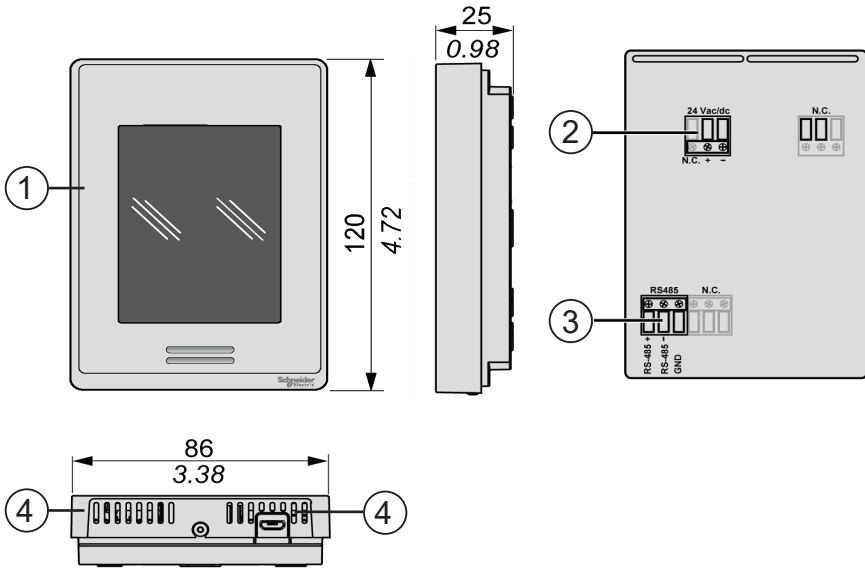

ILL3672-A

Number	Description
1	Colour touchscreen
2	Power supply connector
3	RS 485 Modbus connector
4	Holes for temperature and humidity measurement

The Multi-Magic Wall Controller should be placed indoors, approximately 1.5 metres (5') above the floor, in the same zone in which cooling is required. Placement is critical for correct functioning of the temperature and humidity sensors inside the Controller.

The following points must be taken into consideration:

- Avoid direct sunlight exposure.
- Avoid mounting on external walls.
- Avoid mounting the wall controller near heat sources such as stoves and televisions.
- Do not locate in the direct airflow of the duct outlets.
- Do not locate in strong drafts or in dead spots such as cupboards/drawers.
- Always seal the wall cable entry hole.
- Avoid blocking or restricting the vent holes located on the underside of the Wall Controller, as this is where the sensors are located. **Important!** Drafts within the wall cavity can impact the temperature and humidity reading of the wall control. We recommend that the cable access hole be sealed, but in such a way that the cable can still retreat into the wall cavity.
- The Wall Controller shall be mounted vertically.

PHYSICAL DESCRIPTION & MOUNTING

WALL CONTROLLER INSTALLATION INSTRUCTIONS

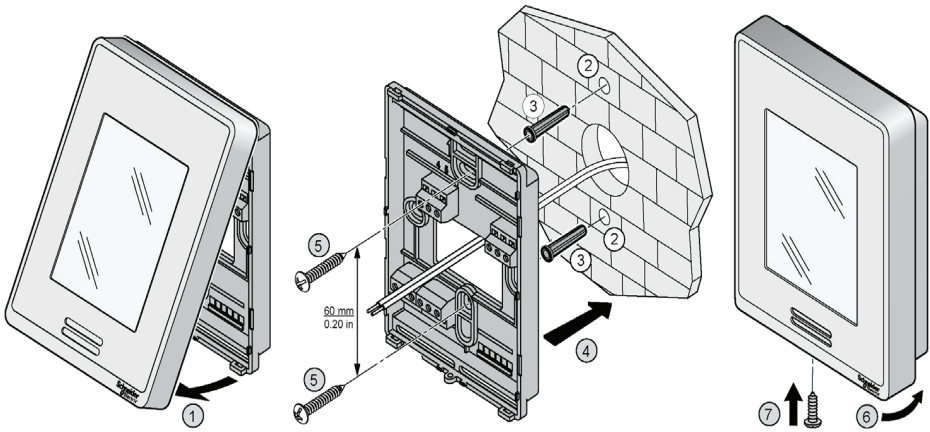

ILL3670-A

Step	Action
1	Open unit by pulling on bottom side of the display (1)
2	Ensure correct side of base faces up
3	Pull cables 150 mm (5.90 in.) out from wall
4	Align base and mark location of two mounting holes on wall or panel (2)
	<p>CAUTION!</p> <p>Always make sure there are no electrical cables, gas or water pipes, or the like, behind where you intend to drill.</p>
5	Install anchors (NOT INCLUDED) in wall (3)
6	Insert cable in central hole of base
7	Place rear cover on the wall and align it with mounting holes (4)
8	Insert screws (NOT INCLUDED) in mounting holes on each side of base (5)
9	Insert POWER and CONTROL wiring according to wiring chart
10	Gently push excess wiring back into hole
11	Gently align cover to top of base and snap in place from bottom (6)
12	Install the isolated screw connection for securing the plastic housing (7)

CONNECTING

COMMUNICATION CABLE SPECIFICATION

- Suitable for Modbus RS 485 applications
- Minimum 1 twisted pair (TP) and a third conductor
- Copper Conductors
- 0.5 mm² / AWG 20
- Braided Shield with Drain Wire
- Characteristic impedance 120Ω
- Nominal capacity between conductors 89 pF/m
- Nominal capacity between conductors and shielding 161 pF/m

Use the twisted pair for the '+' and '-' signal terminals. Use the 3rd conductor for the signal GND terminals. Attach the braided shield / drain wire to the EARTH terminal at one end only.

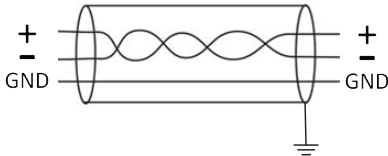

ILL3705-A

WIRING REQUIREMENTS

- Communication wiring must be kept separate from AC power wiring.
- Always route communication cables at least 300mm (12") away from high voltage cables and high-power machines.
- Crossover high power cables at right angles.
- Maximum cable length to the first cooler is 100m.
- Maximum cable length between each cooler is 100m.

Note: Non-shielded cables are not protected against electromagnet interference which can cause signal degradation.

Attach the 120Ω resistor (supplied with Wall Controller) between the "+" and "-" terminals of the Wall Controller

Attach the 120Ω resistor (supplied with Multi-Magic coolers) between the "+" and "-" terminals of the last cooler on the RS 485 Modbus network.

Do not fit the 120Ω resistor to coolers installed between the Wall Controller and the last cooler..

See Appendix for example wiring schematics

mm in. 7 0.28						
mm ²	0.2...2.5	0.2...2.5	0.25...2.5	0.25...2.5	2x 0.2...1	2x 0.2...1.5
AWG	24...14	24...14	22...14	22...14	2x 24...18	2x 24...16

mm in. 7 0.28				
mm ²	2x 0.25...1	2x 0.5...1.5		Ø3.5mm (0.14in)
AWG	2x 22...18	2x 20...16		N/m 0.5...0.6 lb/in 4.42...5.31

ILL3669-A

CONNECTING

POWER

Characteristic	Specification
Power supply	24 V AC/DC +/-10 %
Power consumption	3.2 VA 1.3 W max
Fuse Recommendation (not included)	Type T 500mA

The Multi-Magic Wall Controller can be powered by either a cooler on the network or a dedicated power supply.

Note: Should a networked cooler be used for providing power, turning power off the cooler will prevent the Wall Controller from controlling the remaining coolers on the network.

Use proper wire sizes to meet voltage and current requirements and use copper conductors.

If using a dedicated power supply, it must be rated Safety Extra Low Voltage (SELV) according to IEC 61140. These sources of power are isolated between the electrical input and output circuits of the power supply as well as simple separation from ground (earth), PELV, and other SELV systems.

WALL CONTROLLER

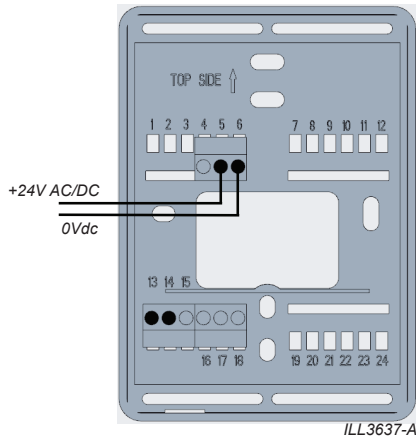

ILL3637-A

CW-H COOLER

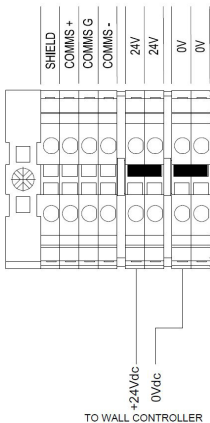

ILL3639-C

CW-80 COOLER

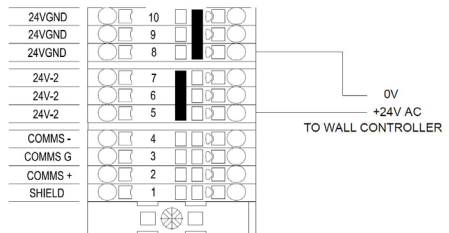

ILL3880-A

CONNECTING

TERMINATING RESISTOR

Attach the 120Ω resistor (supplied with Wall Controller) between the “+” and “-” terminals of the Wall Controller

WALL CONTROLLER

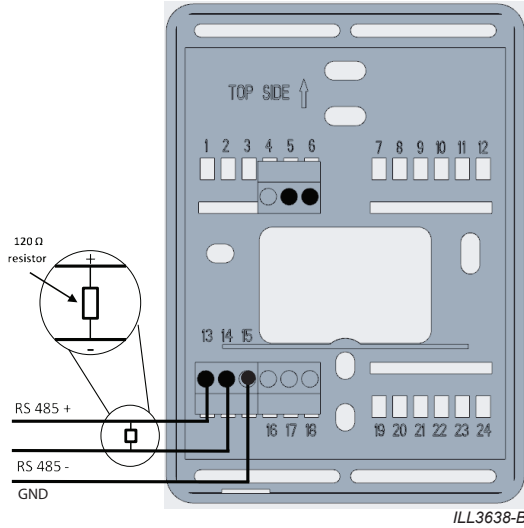

Attach the 120Ω resistor (supplied with coolers) between the “+” and “-” terminals of the **LAST** cooler on the RS 485 Modbus network.

CW-H COOLER

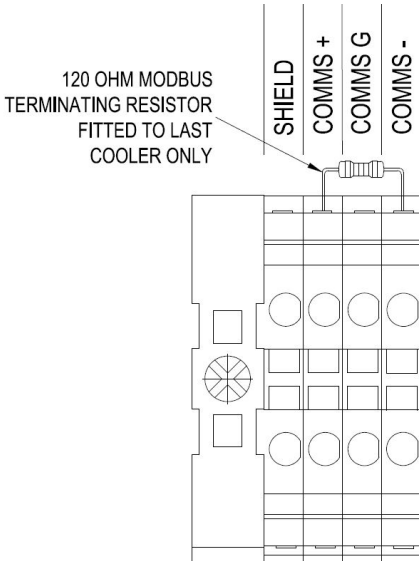

CW-80 COOLER

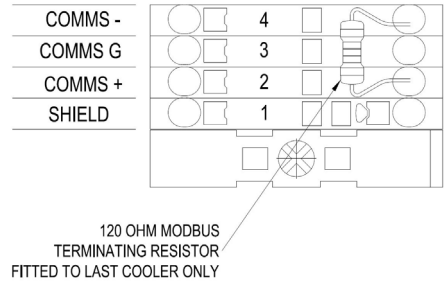

OPERATION SCREENS

MAIN MENU

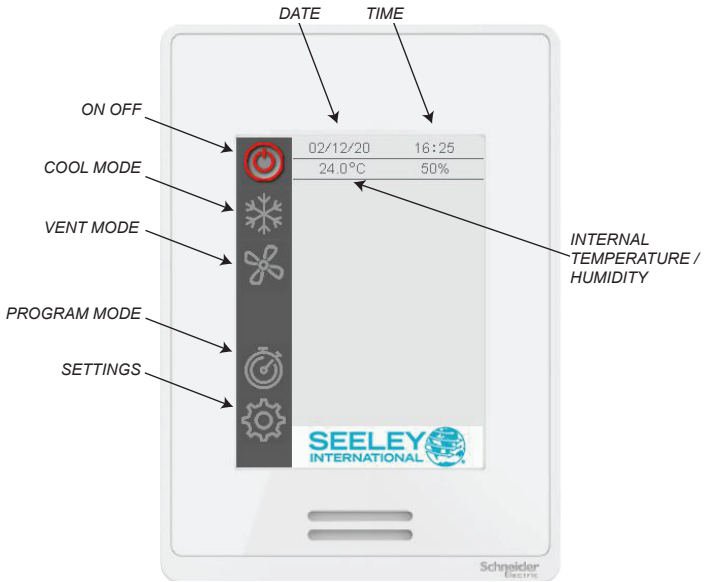

ILL3632-B

OPERATION SCREENS

COOL MODE (MANUAL SPEED CONTROL)

Use COOL mode with manual speed control to keep the connected cooler(s) running at a constant fan speed.

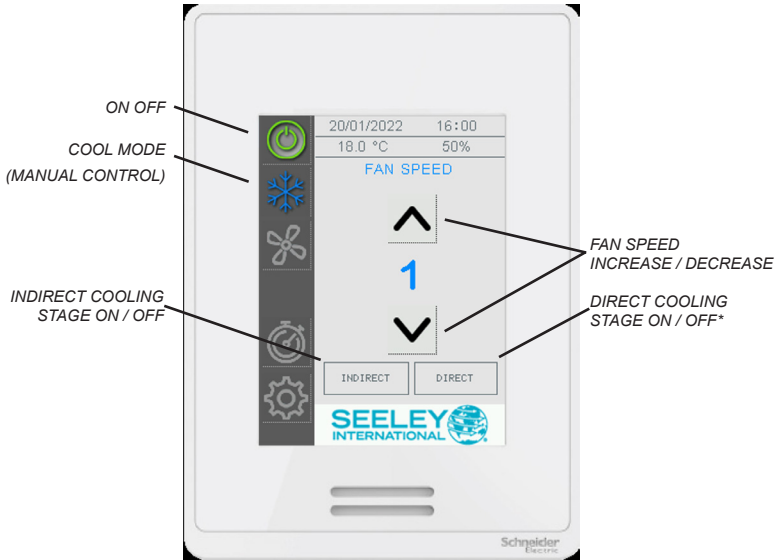

ILL3642-C

To enable COOL mode with manual speed control,

- Press the ON-OFF button.
- Press the COOL mode button once.
- Press the INDIRECT and/or DIRECT* buttons as required to enable the respective cooling stages.
- Press the FAN SPEED UP DOWN arrow buttons to set fan speed.

***Note:** The DIRECT cooling stage button is only available if Supercool cooler(s) are detected during Network Setup.

***Note:** The DIRECT cooling stage can only be turned ON if the INDIRECT stage is also ON.

OPERATION SCREENS

COOL MODE (AUTOMATIC SPEED CONTROL)

Use COOL mode with automatic speed control to maintain space temperature and relative humidity* by automatically varying the connected cooler(s) fan speed.

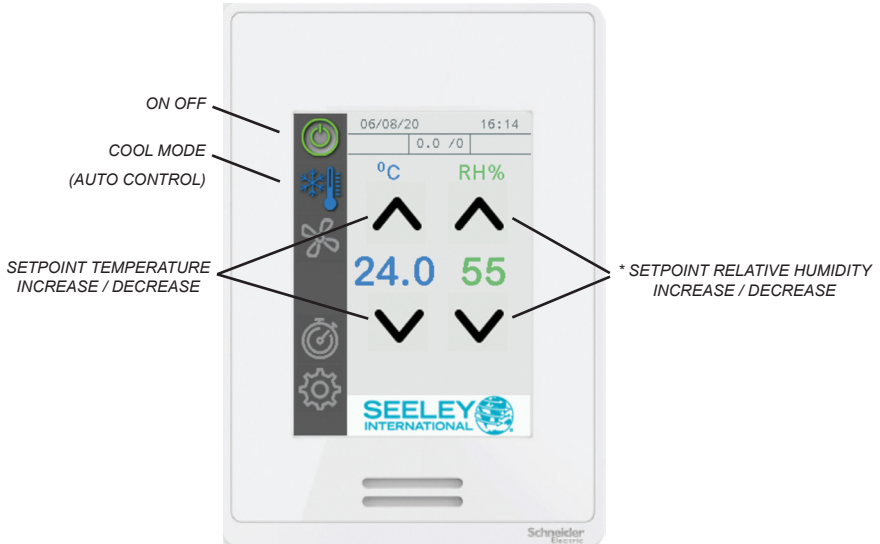

ILL3643-C

To enable COOL mode with automatic speed control,

- Press the ON-OFF button.
- Press the COOL mode button twice.
- Set the target internal temperature. Set point can be adjusted in increments of 0.5 °C (1 °F) between 15 °C and 30 °C (60 °F and 85 °F).
Connected cooler(s) fan speed will be adjusted to try to maintain this temperature.
- Set the target Relative Humidity (RH)*. Set point can be adjusted in increments of 5 % between 50% and 90%.
Connected cooler(s) will enable the DIRECT cooling stage if measured internal RH is lower than the set point.
Connected cooler(s) will disable the DIRECT cooling stage if measured internal RH is higher than the set point.

***Note:** RH set point buttons are only available if Supercool cooler(s) are detected during Network Setup.

OPERATION SCREENS

VENT MODE

Use VENT mode with manual speed control to keep connected cooler(s) running at a constant speed with no cooling stage enabled.

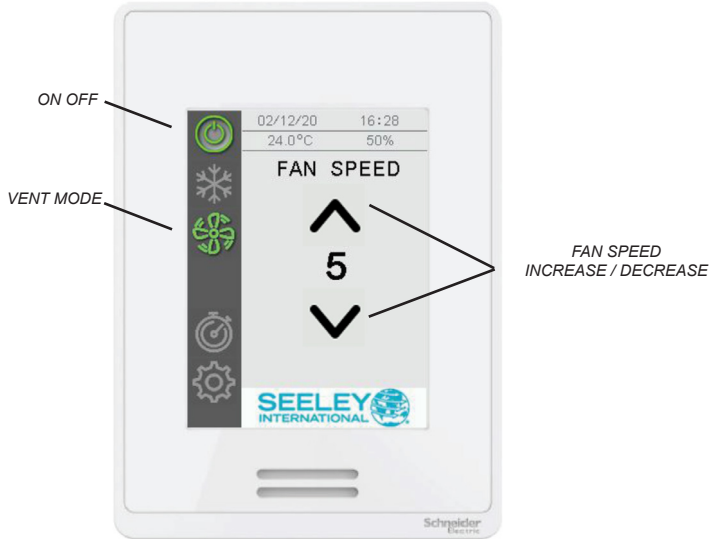

ILL3644-D

To enable VENT mode with manual speed control,

- Press the ON-OFF button.
- Press the VENT mode button.
- Press the FAN SPEED UP DOWN arrow buttons to set fan speed.

OPERATION SCREENS

PROGRAM MODE

Use PROGRAM mode to maintain space temperature and relative humidity* on a "set and forget" seven-day program.

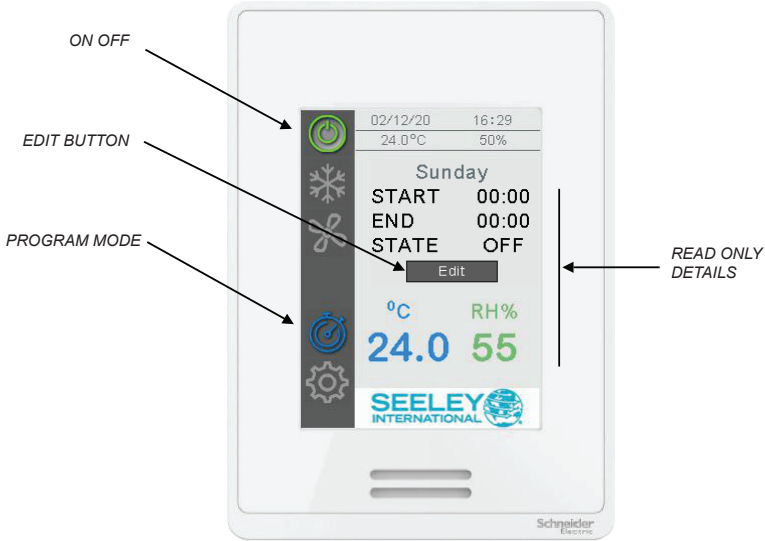

ILL3645-C

When PROGRAM mode is enabled, the wall controller will check the current day, time, temperature and relative humidity set points against the real time/current values and run the connected cooler(s) as required.

To enable PROGRAM mode,

- Press the ON-OFF button.
- Press the PROGRAM mode button.

The controller will display the current time period.

***Note:** Relative humidity set point options are only available if Supercool cooler(s) are detected during Network Setup.

OPERATION SCREENS

EDIT THE 7-DAY PROGRAM

To edit the 7-day program, press the EDIT button..

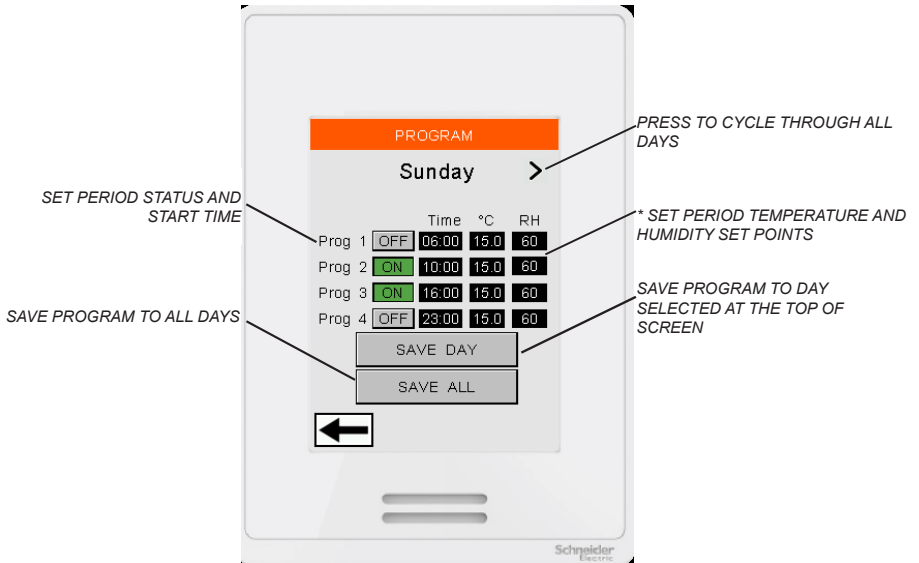

ILL3653

Each day is divided into four time periods with the user able to set when each of these periods starts and ends and the required temperature / relative humidity* set-points.

In the above example, the connected coolers are programmed for the following sequence;

07:00 – Turn ON, with set-points of 24C and 60% RH

11:00 – Turn OFF (set-points are ignored)

16:00 – Turn ON, with set-points of 24C and 60% RH

22:00 – Turn OFF (set-points are ignored)

Press the left and right arrow buttons to cycle through each day of the week. When finished setting a schedule for a particular day, press SAVE DAY. Alternatively, press SAVE ALL to save the shown schedule to all days.

***Note:** Relative humidity set point options are only available if Supercool cooler(s) are detected during Network Setup.

SETTING SCREENS

MENU



ILL3646-B

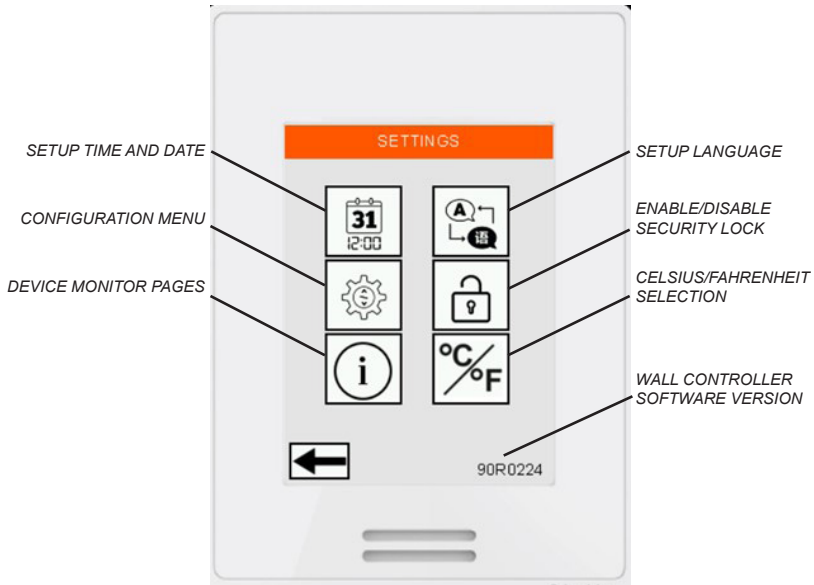

ILL3647

SETTING SCREENS

TIME AND DATE

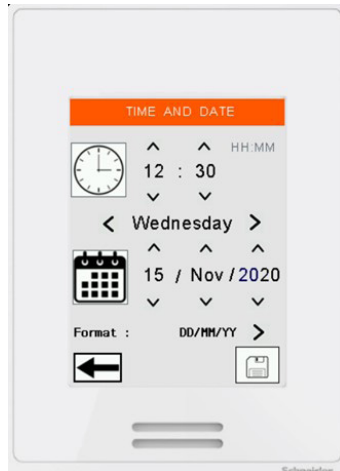

To adjust the time and date, press the up/down buttons for each field. When finished, press SAVE.

These values are used in the PROGRAM mode and for time stamping fault codes

LANGUAGE



To change the Wall Controller language press the Change Language box and select from ENGLISH (default), SPANISH, ITALIAN, FRENCH or PORTUGUESE.

Note: The Wall Controller will automatically restart if the language is changed.

SETTING SCREENS

SECURITY LOCK

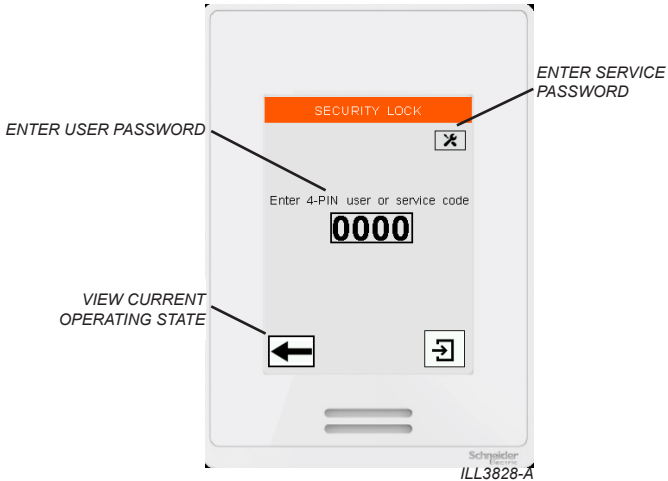

First Time Use. Upon enabling Security Lock for the first time, the user is required to set a 4 digit user passcode.

If enabled, the Security Lock screen will appear 60 seconds after the screen has been idle. Enter the user passcode to remove the Security Lock screen and make changes to the Wall Controller operating mode.

Press the back button to view the Wall Controller operating mode. No changes are allowed.

Press the Service Button to enter the Seeley Service 7378 passcode. Full access is granted.

If the user passcode is entered incorrectly 5 times the reset 5331 passcode is required.

TEMPERATURE UNITS

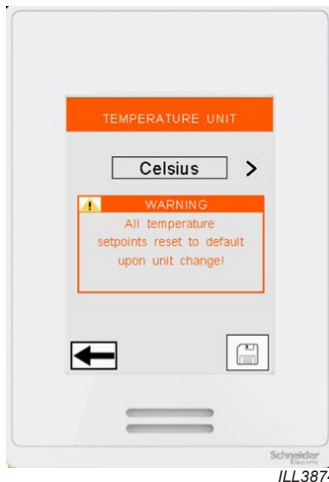

PRESS BUTTON TO CHANGE BETWEEN DEGREES CELSIUS AND DEGREES FAHRENHEIT

NOTE: WHEN UNITS ARE CHANGED AUTOMATIC PROGRAM MODE TEMPERATURE SET POINTS ARE RESET

CONFIGURATION SCREENS

MENU

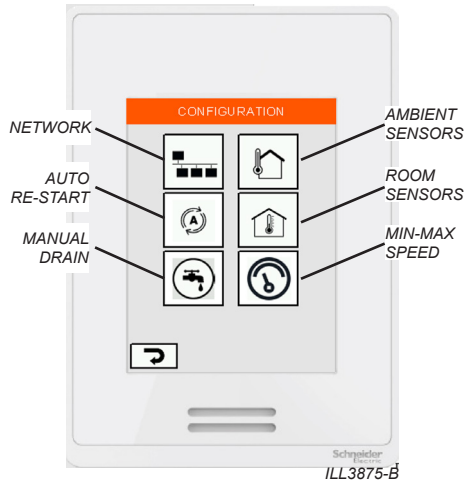

AUTO-RESTART

ON: After a power failure, all connected coolers will resume running in the last selected operating mode.

OFF: After a power failure, all connected coolers will remain off. To resume running, a user is required to select an operating mode.

MANUAL DRAIN

Press this button to initiate a manual water drain on all connected coolers. When triggered, the drain valve will open and stay open for at least 10 minutes.

During this period, all pumps will stop and the inlet solenoid valve will remain closed, however the fan will continue to run at the requested speed.

Once triggered, it is not possible to close the drain valve again until the 10 minutes as elapsed. After 10 minutes the coolers will resume running in requested operating mode.

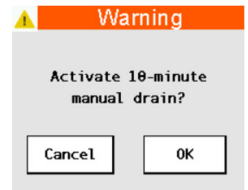

ILL3914-B

ROOM SENSORS

Connected coolers can be used with additional room/internal temperature and relative humidity sensors, each sold and supplied separately, for use in AUTOMATIC COOL and PROGRAM modes. Use the Room Sensor screen to view individual sensor values. Refer to literature provided with the sensor for installation and setup instructions.

AMBIENT SENSORS

Connected coolers can be used with additional ambient/external temperature and relative humidity sensors, each sold and supplied separately. Use the Ambient Sensor screen to view individual sensor values and to enable AMBIENT CONDITION MONITORING mode. Refer to literature provided with the sensor for installation and setup instructions.

NOTE! Ambient Condition Monitoring mode is not compatible with the Minimum/Maximum Fan Speed functions. When Minimum/Maximum Fan Speed mode is enabled, Ambient Condition Monitoring is automatically disabled.

CONFIGURATION SCREENS

MINIMUM - MAXIMUM FAN SPEED LIMITS

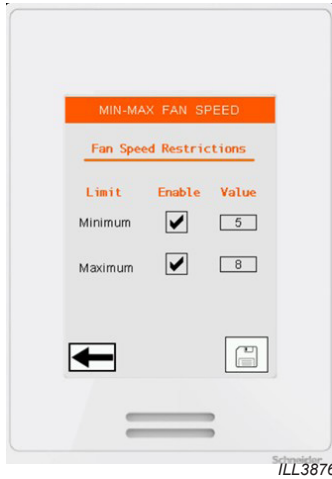

Check the box to set specified minimum and maximum fan speed limits between Speeds 1 and 10.

Minimum Speed

For Vent Mode and Cool Mode (Manual Speed Control)

- Users will be unable to manually select a fan speed below the specified minimum limit.

For Cool Mode (Automatic Speed Control) and Program Mode

- Connected cooler(s) fan speed will not automatically go below the specified minimum limit.
- "SPEED LIMITED" warning will appear on the main page when limit is active.
- At the temperature set point, the connected cooler(s) fan speed is maintained at the specified minimum speed, the INDIRECT cooling stages are maintained, whilst the DIRECT cooling stages* are turned off.
- At 0.5°C (1.0°F) below temperature set point, the connected cooler(s) fan speed is maintained at the specified minimum speed and the INDIRECT cooling stages are turned off.

***Note:** DIRECT coolings stages are only available on Supercool coolers.

Maximum Speed

For Vent Mode and Cool Mode (Manual Speed Control)

- Users will be unable to manually select a fan speed above the specified maximum limit.

For Cool Mode (Automatic Speed Control) and Program Mode

- Connected cooler(s) fan speed will not automatically go above the specified maximum limit.
- "SPEED LIMITED" warning will appear on the main page when limit is active.

NOTE! Ambient Conditioning Monitoring mode is not compatible with the Minimum/Maximum Fan Speed functions. When Minimum/Maximum Fan Speed mode is enabled, Ambient Conditioning Monitoring is automatically disabled.

CONFIGURATION SCREENS

MODBUS RS 485 NETWORK SETUP

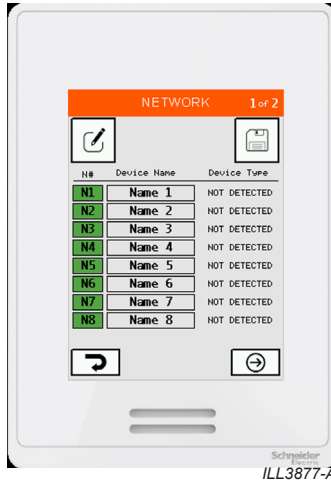

IMPORTANT - The Wall Controller can control up to 15 CW-H and/or CW-80 coolers. Ensure each cooler is powered up, has a unique node address set, and a 120Ω Modbus terminating resistor is fitted to the Wall Controller and the **LAST** cooler in the network. Refer to installation literature provided with the coolers for setup instructions.

Nodes 1 to 8 are shown on Page 1, Nodes 9 to 15 are shown on Page 2.

- Green square = Cooler detected at node. Type of cooler will be displayed.
- Empty square = No cooler detected at node. DEVICE NOT DETECTED displayed.
- Press SAVE to commit detected coolers to Wall Control memory. Unused nodes will be removed from the list.

Press the NAME field to type in a user specified name or asset tag for the cooler.



If changes to the RS 485 Modbus network are required (e.g. adding or removing a cooler), press MODIFY to re-scan all nodes.



Press SAVE to commit detected coolers to Wall Control memory. Unused nodes will be removed from the list.



Alert will be shown when two or more coolers detected at the same node address.

ModBus Configuration Error

Error will be shown when no coolers are found on the network.

ILL3831-A

DEVICE MONITOR SCREENS

MENU

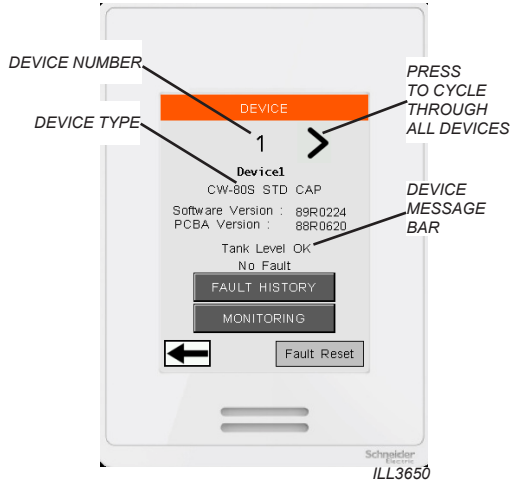

Use the DEVICE screen to access information about individual coolers installed on RS 485 Modbus network. Press the LEFT and RIGHT buttons to access each node address.

The fault message bar at the bottom will display any active faults. If multiple active faults are present, the message will cycle through each in turn. Use the FAULT RESET button to clear all active faults.

The MESSAGE BAR contains useful information about the current cooler status and will cycle through all active messages.

MESSAGE	DESCRIPTION
STANDBY	Cooler is ON but no control input active.
VENT MODE	Fan is running but no cooling stage is on.
TANK INITIAL FILL	Inlet Water Solenoid is on and water is entering the tank. Pumps will not start until the tank is full.
PRE-WET FS LIMITED	Pre-Wet is enabled. The pumps are running for an extra 2 minutes whilst the fan speed is limited.
FAN START DELAY	Fan start delay is enabled. Fans will start after the delay timer has expired.
INDIRECT PUMP RUNNING	IEC COOL MODE - IEC pump is running. Pump cycles ON for 1 minute and OFF for 8 minutes.
CORE DRAIN	IEC COOL MODE - IEC pump have just turned OFF and water is returning back to tank.
TANK FILL-IEC	IEC COOL MODE - Inlet Water Solenoid is on and water is entering the tank.
TANK LEVEL OK	IEC COOL MODE - Tank is full, waiting for IEC pumps to start.
TANK FILL-DEC	DEC COOL MODE - Inlet Water Solenoid is on and water is entering the tank.
DEC SATURATION	DEC COOL MODE - DEC pump is pulsing ON/OFF to slowly wet the Chillcel media.
DIRECT PUMP RUNNING	DEC COOL MODE - DEC pump is running. Pump runs continuously.
SALINITY DRAIN	Tank water has reached the maximum salinity level and a partial tank drain and fill cycle is in progress.
CLEAN WATER DRAIN	The chlorinator has not run for 24 hours and a complete tank drain and fill cycle is in progress.
TANK DRAIN	3-day tank drain delay or manual drain triggered.
FREEZE PROTECTION	The tank has drained to prevent water freezing.

DEVICE MONITOR SCREENS

COOLER MONITOR

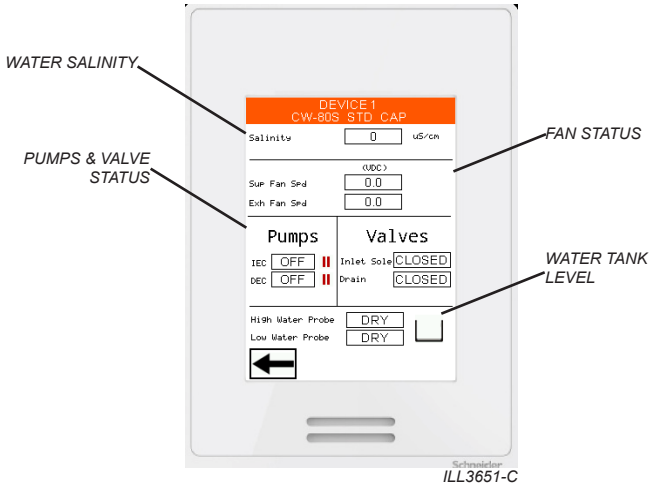

The monitor screen displays the status of each of the important components of the cooler.

FAULT HISTORY

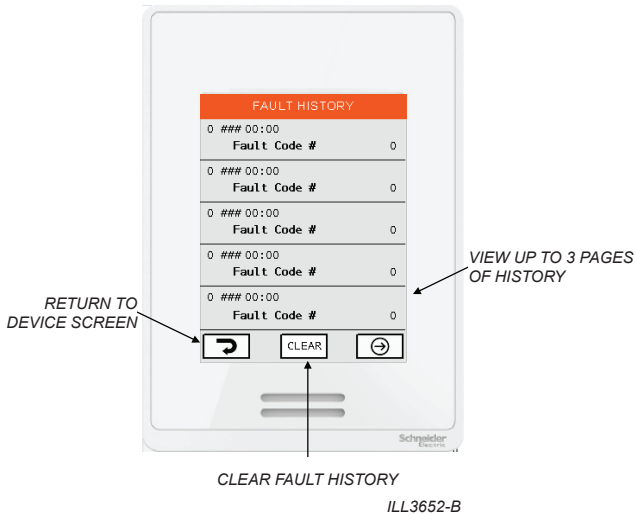

Use the FAULT HISTORY screen to view a log of faults associated with the cooler. Each fault is time stamped based on the settings from the TIME AND DATE screen. Press NEXT to cycle through 3 pages of fault history. Press CLEAR to remove all historical faults.

REMOTE BMS LOCK

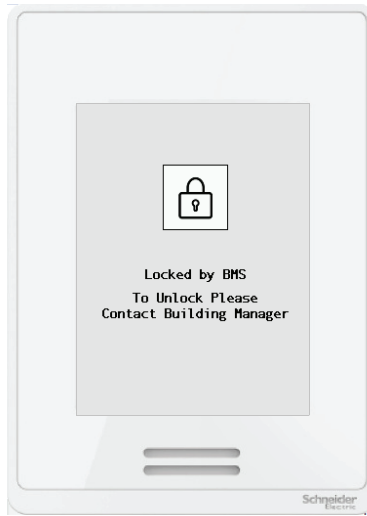

ILL3832-A

Use the BMS IEC or DEC input terminals on any connected cooler to remotely shutdown all connected coolers and lock the Wall Controller. When applied, no cooler control from the Wall Controller is possible and all connected coolers will display "REMOTE SHUTDOWN".

- Remove the input signal to resume running in the last known Wall Controller operating mode.
- Refer to Appendix for example wiring schematic.

Note: Connected devices must have software 89R0821 or later installed for this feature to work.

This feature may be useful when Building Managers wish to remotely shutdown coolers during certain hours (e.g. overnight). This prevents Wall Controllers from being accidentally left on when the cooling space is unoccupied.

COOLER FAULTS AND TROUBLESHOOTING

FAULT SCREEN DISPLAY

Should a connected cooler detect a fault the following pop-up screen will appear on the Wall Controller.



Scan the QR Code with a compatible smartphone to be directed to the Seeley International Climate Wizard Technical Documents website.

Press RESET to remove the pop-up screen and restart the effected cooler. If the fault re-occurs the pop-up screen will re-appear.

Press IGNORE to remove the pop-up screen. The fault will remain active in the background and a warning triangle will appear on the main page until the fault is reset.

All fault codes are added to the FAULT HISTORY screen of the individual cooler.

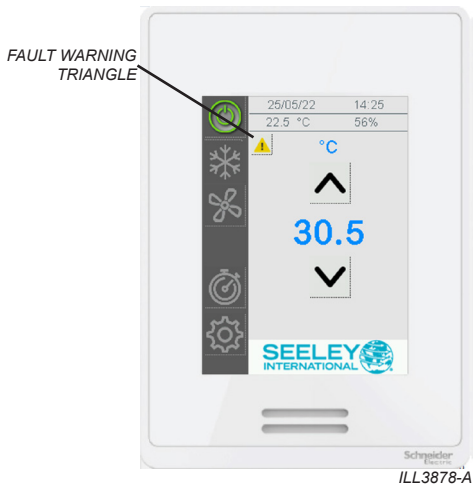

COOLER FAULTS AND TROUBLESHOOTING

FAULT CODE DESCRIPTIONS

All faults below shut the individual cooler down unless stated. Other coolers on the same RS 485 Modbus network will continue to run.

For cooler faults, please refer to the cooler manual for further details.

Code	Component	Fault Description
FC 1	COOLER	PLC – PCBA COMMUNICATION FAILURE
FC 2	COOLER	FAILURE TO DETECT WATER AT LOW PROBE
FC 3	COOLER	FAILURE TO DETECT WATER AT HIGH PROBE
FC 4	COOLER	FAILURE TO CLEAR LOW PROBE DURING DRAIN
FC 5	COOLER	WATER DETECTED AT HIGH PROBE BUT NOT LOW PROBE
FC 7	COOLER	SUPPLY FAN MOTOR ERROR
FC 9	COOLER	PLC EXPANSION COMMUNICATION FAULT
FC 10	COOLER	CHLORINATOR FAULT
FC 11	SENSOR	<p>ROOM AIR SENSOR FAULT</p> <p>Temperature or Relative Humidity input has been 0V or 10V for 10 minutes. Check sensor values at PLC cooler screen “SENSORS” menu. Check sensor wiring connections. If no sensor fitted, check sensor has not been accidentally enabled the PLC. This is a running fault. Connected cooler(s) will not turn off.</p>
FC 12	SENSOR	<p>AMBIENT AIR SENSOR FAULT</p> <p>Temperature or Relative Humidity input has been 0V or 10V for 10 minutes. Check sensor values at PLC cooler screen “SENSORS” menu. Check sensor wiring connections. If no sensor fitted, check sensor has not been accidentally enabled the PLC. This is a running fault. Connected cooler(s) will not turn off.</p>
FC 13	COOLER	EXHAUST FAN MOTOR ERROR
FC 14	SENSOR	<p>DUCT AIR SENSOR FAULT</p> <p>Temperature or Relative Humidity input has been 0V or 10V for 10 minutes. Check sensor values at PLC cooler screen “SENSORS” menu. Check sensor wiring connections. If no sensor fitted, check sensor has not been accidentally enabled the PLC. This is a running fault. Connected cooler(s) will not turn off.</p>
FC 15	SENSOR	<p>PRESSURE SENSOR FAULT</p> <p>Pressure input has been 0V or 10V for 10 minutes. Check sensor values at PLC cooler screen “SENSORS” menu. Check sensor wiring connections. If no sensor fitted, check sensor has not been accidentally enabled the PLC. This is a running fault. Connected cooler(s) will not turn off.</p>
FC 16	WALL CONTROLLER	<p>WALL CONTROLLER COMMUNICATION FAILURE</p> <p>Wall Controller has lost communication with cooler. Ensure cooler is powered up. Check communication cable connections between Wall Controller and cooler, including 120Ω Modbus terminating resistors. Check communication cable connections between cooler terminals and cooler PLC.</p>

COOLER FAULTS AND TROUBLESHOOTING

OTHER POTENTIAL PROBLEMS

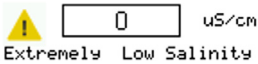
Problem	Suggested Remedy
Cannot find cooler(s) on RS 485 Modbus network	Ensure cooler is powered up. Ensure cooler control is set to WC (Wall Controller). Ensure cooler has a unique node address set.
	Refer to installation literature provided with the cooler for setup instructions
	Check SETTINGS – CONFIGURATION - NETWORK to review installed coolers. Press MODIFY to re-scan all nodes.
	If “DEVICE NOT DETECTED” is displayed, check RS 485 cabling between wall control and cooler. Check 120Ω Modbus terminating resistor is fitted to the Wall Controller and the last Cooler in the network. When the Modbus network is connected correctly, a measurement of 60Ω should present at any point in the network.
Cooler(s) not running	The Wall Controller is not in COOL mode with either INDIRECT or DIRECT cooling stages selected.
	The set temperature has been achieved and the coolers are in standby.
	The Controller is in PROGRAM mode and the current time period specifies the cooler is “OFF”. Review the schedule via the PROGRAM- EDIT screen.
	Check SETTINGS – DEVICE – FAULT HISTORY. Check and rectify Faults
Temperature and/or Relatively Humidity values are not steady/ constantly changing	Avoid blocking or restricting the vent holes located on the underside of the Controller, as this is where the sensors are located.
	Check for damage to circuit board on back of controller. Water, debris, insects can access through unsealed wall cable entry holes.
	Replace Wall Controller.
Temperature and/or Relatively Humidity values always reading low.	Temperature and Relative Humidity values on the main screen are an average of all sensors connected to the coolers. Average values may be lower than expected if including sensor reading from faulty or missing sensors.
Touchscreen unresponsive	Clean screen. Do not use harsh chemical cleaners, for best results use distilled water or a touchscreen specific cleaning agent with a microfibre cloth.
	Remove and reapply power to Wall Controller to force a reboot
	Replace Wall Controller
Forgotten User Password (Entered user passcode incorrectly 5 times).	When requested, enter RESET passcode 5331
Extremely Low Salinity warnings in Device Monitor	<p>To allow a water Salinity supplier the Device Monitor</p>  <p>Extremely Low Salinity</p> <p>µS/cm</p> <p>Coolers require 1. When water warning is shown in</p> <p>Coolers may continue to run, but at an increased risk of Fault Code 2 (Failure to detect water at Low Prove) and Fault Code 3 (Failure to detect water at High Probe).</p>

APPENDIX - EXAMPLE WIRING SCHEMATIC

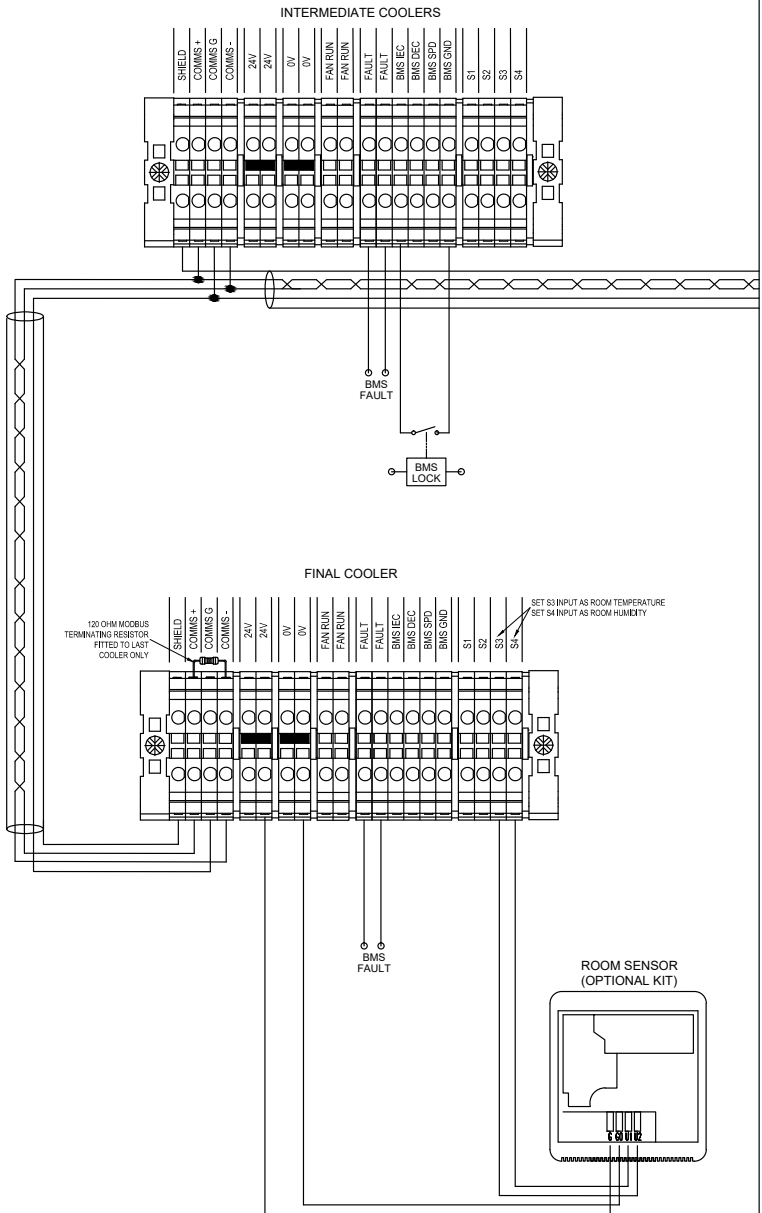

FIRST COOLER

SET S1 INPUT AS AMBIENT TEMPERATURE
SET S2 INPUT AS AMBIENT HUMIDITY

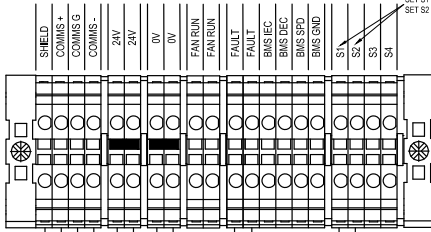

AMBIENT SENSOR
(OPTIONAL KIT)

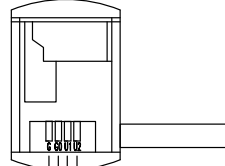

WALL CONTROLLER

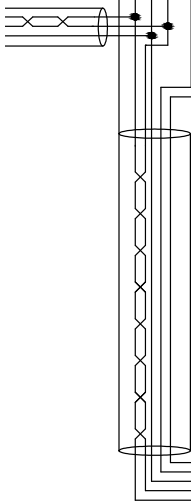
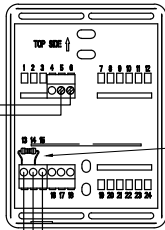

BMS
FAULT



Warranty Service

Australia: 1300 650 644

New Zealand: 0800 589 151

Seeley International Technical Support

Australia: 1300 650 399

New Zealand: 0800 589 152

For all other regions, contact your local distributor:

seeleyinternational.com

Online Support Portal (AUS/NZ)

Scan or Click QR Code



It is the policy of Seeley International to introduce continuous product improvement.

Accordingly, specifications are subject to change without notice.

Please consult with your dealer to confirm the specifications of the model selected.